Comfort-Cire® **Century**®
SE Series

Multi-Position Air Handler
AMP**S1A
PSC Motor

Instruction Manual





RECOGNIZE THIS SYMBOL AS AN INDICATION OF IMPORTANT SAFETY INFORMATION

 **WARNING**

These instructions are intended as an aid to qualified licensed service personnel for proper installation, adjustment and operation of this unit. Read these instructions thoroughly before attempting installation or operation. Failure to follow these instruction may result in improper installation, adjustment, service or maintenance possibly resulting in fire, electrical shock, property damage, personal injury or death.

 **WARNING**

Proposition 65: This appliance contains fiberglass insulation. Respirable particles of fiberglass are known to the state of California to cause cancer. For more information, go to www.P65Warnings.ca.gov."

Air Handler Features

- Multi-speed blower motor.
- TXV easily installed.
- Multi-position installation - upflow or horizontal right standard; field convertible to horizontal left or downflow.
- Multiple electrical entry locations.
- Field-installed electric heater kits 5, 7.5, 10, 15, 20 kW available as an accessory.
- Dual front panel design for ease of maintenance.
- Blower and coil easy slide out for ease of maintenance.
- Fully-insulated cabinet design.
- Horizontal and vertical condensate drain pans standard.
- Condensate drain pan is polymer with UVC inhibitor.
- Primary and secondary condensate drain fittings.
- Factory-sealed cabinet certified to achieve 2% or less air leakage rate at 1.0 inch water column.
- Integrated filter rack with tool-less door access.
- AHRI and ETL listed.

CONTENTS

1 SAFETY	01
2 GENERAL	
• 2.1 Unit Dimensions	04
3 APPLICATIONS	
• 3.1 Vertical Upflow	05
• 3.2 Vertical Downflow	05
• 3.3 Horizontal	05
• 3.4 Installation In An Unconditioned Space	07
4 ELECTRICAL WIRING	
• 4.1 Power Wiring	07
• 4.2 Control Wiring	07
• 4.3 Grounding	07
• 4.4 Electrical Data	08
• 4.5 Heat Kit Data	08
5 AIRFLOW PERFORMANCE	09
6 DUCTWORK	10
7 REFRIGERANT CONNECTIONS	
• 7.1 Condensate Drain Tubing	10
8 AIR FILTER (Not Factory-Installed)	11
9 FILTER INSTALLATION DIMENSIONS	12
10 WIRING DIAGRAM	13
11 PISTON/TXV INSTALLATION	16

This document is customer property and should remain with this unit. These instructions do not cover all the different variations systems nor does it provide for every possible contingency to be met in connection with installation. All phases of this installation must comply with national, state, and local codes. If additional information is required, please contact your local distributor.

1 SAFETY



This is a safety alert symbol. When you see this symbol on labels or in manuals, be alert to the potential for personal injury.



This is an attention alert symbol. When you see this symbol on labels or in manuals, be alert to the potential for personal injury.

WARNING

Disconnect all power to unit before installing or servicing. More than one disconnect switch may be required to de-energize the equipment. Hazardous voltage can cause severe personal injury or death.

WARNING

If removal of the blower assembly is required, all disconnect switches supplying power to the equipment must be de-energized and shutoff (if not in sight of unit) so the field power wires can be safely removed from the blower assembly. Failure to do so can cause electrical shock resulting in personal injury or death.

WARNING

Because of possible damage to equipment or personal injury, installation, service, and maintenance should be performed by a trained, qualified service personnel. Consumer service is recommended only for filter cleaning/replacement. Never operate the unit with the access panels removed.

WARNING

These instructions are intended as an aid to qualified, licensed service personnel for proper installation, adjustment and operation of this unit. Read these instructions thoroughly before attempting installation or operation. Failure to follow these instructions may result in improper installation, adjustment, service or maintenance possibly resulting in fire, electrical shock, property damage, personal injury or death.

WARNING

The unit must be permanently grounded. Failure to do so can result in electrical shock causing personal injury or death.

WARNING

PROPOSITION 65: This appliance contains fiberglass insulation. Respirable particles of fiberglass are known to State of California to cause cancer.

All manufacturer products meet current federal OSHA Guidelines for safety. California Proposition 65 warnings are required for certain products, which are not covered by the OSHA standards.

California's Proposition 65 requires warnings for products sold in California that contain or produce any of over 600 listed chemicals known to the State of California to cause cancer or birth defects such as fiberglass insulation, lead in brass, and combustion products from natural vapor.

All "new equipment" shipped for sale in California will have labels stating that the product contains and/or produces Proposition 65 chemicals. Although we have not changed our processes, having the same label on all our products facilitates manufacturing and shipping. We cannot always know "when, or if" products will be sold in the California market.

You may receive inquiries from customers about chemicals found in, or produced by, some of our heating and air-conditioning equipment, or found in natural vapor used with some of our products. Listed below are those chemicals and substances commonly associated with similar equipment in our industry and other manufacturers.

Glass Wool (Fiberglass) Insulation
Carbon Monoxide (CO)
Formaldehyde
Benzene

More details are available on the following websites: OSHA (Occupational Safety and Health Administration), at www.osha.gov and the State of California's OEHHA (Office of Environmental Health Hazard Assessment), at www.oehha.org. Consumer education is important since the chemicals and substances on the list are found in our daily lives. Most consumers are aware that products present safety and health risks, when improperly used, handled and maintained.

CAUTION

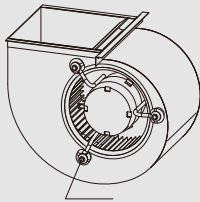

Make sure the blower motor support is tight (3-motor mount bolts), then check to see if wheel is secured to motor shaft before operating unit.

BLOWER MOTOR SHIPPING BOLT

Fig.1-1 CHECKING MOTOR STATUS

WARNING

The first 6 inches of supply air plenum and ductwork must be constructed of sheet metal as required by NFPA 90B. The supply air plenum or duct must have a solid sheet metal bottom directly under the unit with no openings, registers or flexible air ducts located in it. If flexible supply air ducts are used, they may be located only in the vertical walls of rectangular plenum, a minimum of 6 inches from the solid bottom. Metal plenum of duct may be connected to the combustible floor base, if not, it must be connected to the unit supply duct exposed to the supply air opening from the downflow unit. Exposing combustible (non-metal) material to the supply opening of a downflow unit can cause a fire resulting in property damage, personal injury or death.

Exception warning to downflow:
Installations on concrete floor slab with supply air plenum and ductwork completely encased must be not less than 2 inches of concrete (See NFPA 90A).

2 GENERAL

The unit can be positioned for bottom return air in the upflow position, left and right return in the horizontal position, top return in downflow position.

This Air Handler provides the flexibility for installation in any upflow or downflow horizontal application. The direct drive motors provide a selection of air volume.

Top and side power and control wiring, accessible screw terminals for control wiring all combine to make the installation easy, and minimize installation cost. See Fig.2-5.

Do not install unit in an area where flammable materials are present due to the risk of an explosion resulting in serious injury or death.

WARNING

If the supporting structural members are not strong enough to take the unit's weight, the unit could fall out of place and cause serious injury.
If a return-air duct is not installed, carefully select the place and method of product installation so that air flow into the product will not be blocked.

The unit should be installed in a level position to ensure proper condensation drainage. Up to an additional 1/4" rise over the width or depth of the unit is allowed to create additional sloping towards the drain. Unit must be positioned between level and 1/4" rise, sloping toward the drain connections.

Install the indoor unit, power supply wiring and connecting wires at least 3.5 ft. away from televisions or radios in order to prevent image interference or noise.
See Fig.2-1 and Fig.2-2.

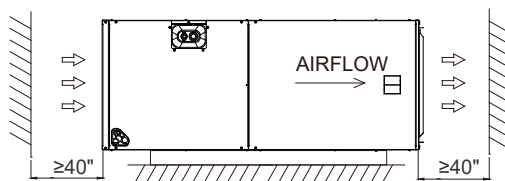

Fig.2-1 CLEARANCES IN THE HORIZONTAL POSITION

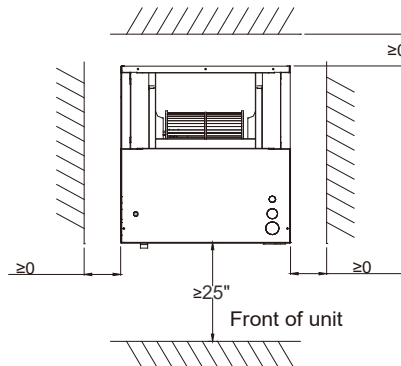

Fig.2-2 CLEARANCES IN THE VERTICAL POSITION

When the unit is installed in a hot and humid place, If the humidity inside the installation space might exceed 86°F and RH 80%, it is recommended to insulate the cabinet exterior.

Use glass wool or polyethylene foam as insulation so that the thickness is more than 2 in. and fits inside the installation space opening.

Respectively, condensation may form on the surface of the insulation.

Be sure to use insulation that is designed for use with HVAC Systems.

Condensation may form on the product during cool operation. It is also recommended to use the second drain pan and secure the unit firmly to prevent it from falling. See Fig.2-3 and Fig.2-4 .

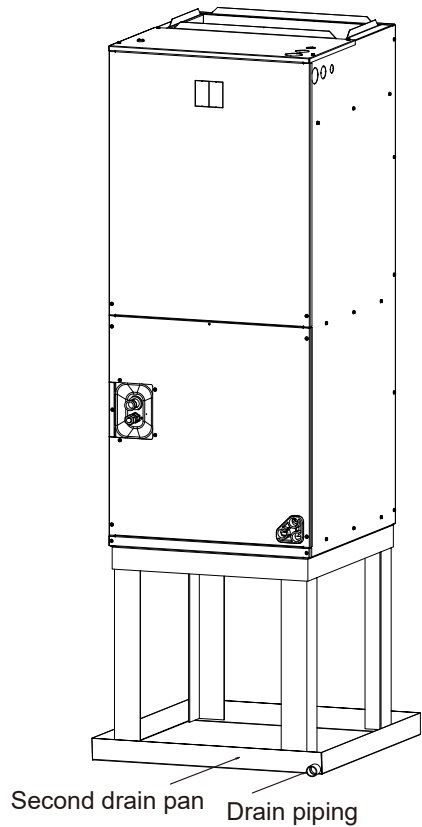

Fig.2-3 INSTALLED VERTICALLY

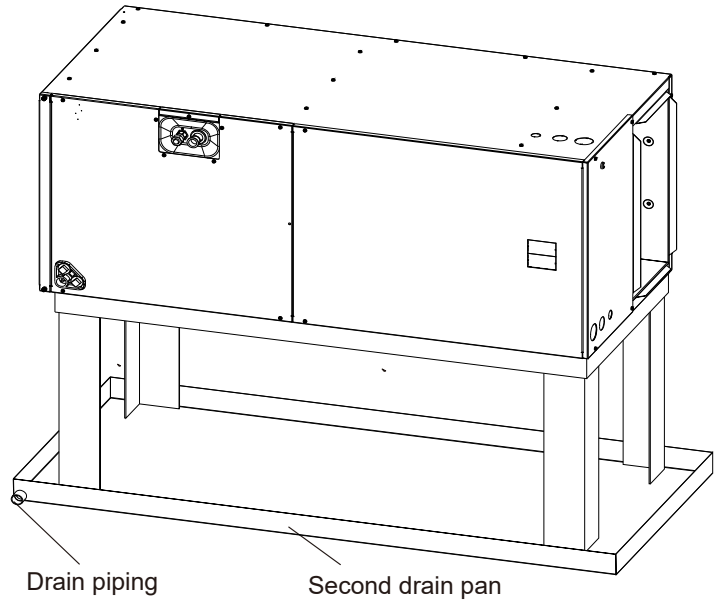
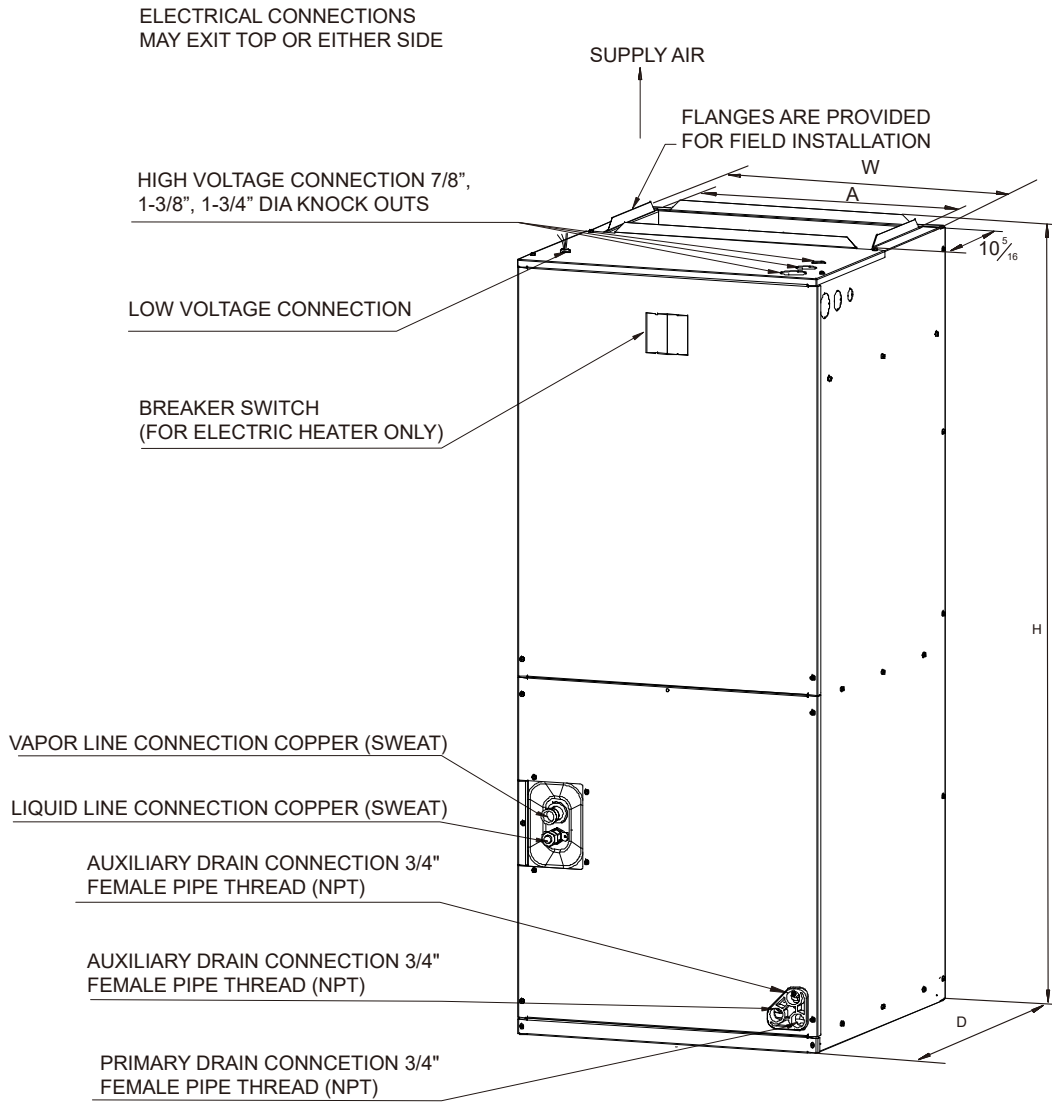

Fig.2-4 INSTALLED HORIZONTALLY

2.1 Unit Dimensions

NOTE: 25" CLEARANCE IS REQUIRED IN THE FRONT OF THE UNIT FOR FILTER AND COIL MAINTENANCE.



UPFLOW UNIT SHOWN;
UNIT MAY BE INSTALLED UPFLOW, DOWNFLOW,
HORIZONTAL RIGHT OR LEFT AIR SUPPLY.

Fig.2-5 DIMENSIONS

DIMENSIONAL DATA

MODEL SIZE	UNIT HEIGHT "H" IN. [mm]	UNIT WIDTH "W" IN. [mm]	UNIT LENGTH "D" IN. [mm]	SUPPLY DUCT "A"	UNIT WEIGHT (LBS.[kg])
24	46-1/2"[1180]	19-5/8"[500]	21-5/8"[550]	18"[456]	128 [58]
36	46-1/2"[1180]	19-5/8"[500]	21-5/8"[550]	18"[456]	128 [58]
48	54-1/2"[1385]	22"[560]	24"[610]	19-1/2"[496]	157 [71]
60	54-1/2"[1385]	22"[560]	24"[610]	19-1/2"[496]	161 [73]

Table 2-1

3 APPLICATIONS

3.1 Vertical Upflow

Upflow is the default factory configuration. See Fig.2-5.

If return air is to be ducted, install duct flush with floor. Use fireproof resilient gasket 1/8 to 1/4 in. thick between the ducts, unit and floor. Set unit on floor over opening.

IMPORTANT NOTE

Torque applied to drain connections should not exceed 15ft.lbs. See Fig.2-5 & 3-1.

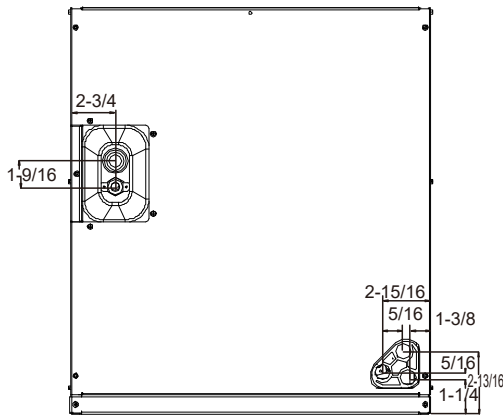

Fig.3-1 DIMENSIONS FOR FRONT CONNECT COIL

3.2 Vertical Downflow

Conversion to Vertical Downflow: A vertical upflow unit may be converted to vertical downflow. Remove the door and indoor coil and reinstall 180° from original position. See Fig.3-2.

IMPORTANT: To comply with certification agencies and the National Electric Code for downflow application, the circuit breaker(s) on field-installed electric heater kits must be re-installed per procedure below so that the breaker switch "on" position and marking is up and, "off" position and marking is down.

- To rotate breaker(s): Rotate one breaker set (circuit) at a time starting with the one on the right. Loosen both lugs on the load side of the breaker. (Make sure that wires are identified and are reinstalled into proper breaker). Wires are bundled with wire ties, one bundle going to the right lug and one bundle going to the left lug.
- Using a screwdriver or pencil, lift white plastic tab with hole away from breaker until breaker releases from mounting opening.
- With breaker held in hand, rotate breaker so that "on" position is up, "off" position is down with unit in planned vertical mounting position. Insert right wire bundle into top right breaker lug, ensuring all strands of all wires are inserted fully into lug, and no wire insulation is in lug.
- Tighten lug as tight as possible while holding circuit breaker. Check wires and make sure each wire is secure and none are loose. Repeat for left wire bundle in left top circuit breaker lug.

- Replace breaker by inserting breaker mounting tab opposite white pull tab in opening, hook mounting tab over edge in opening.
- With a screwdriver or pencil, pull the blue tab with hole away from breaker while setting that side of breaker into opening. When breaker is in place, release tab, locking circuit breaker into location in opening.
- Repeat above operation for remaining breaker(s) (if more than one is provided).
- Replace single point wiring jumper bar, if it is used, on line side of breaker and tighten securely.
- Double check wires and lugs to make sure all are secure and tight. Check to make sure unit wiring to circuit breaker load lugs match that shown on the unit wiring diagram.



Note

The switch on the front of the panel is only used with an electric heater.

3.3 Horizontal

Conversion to Horizontal left: A vertical upflow unit may be converted to horizontal left by removing indoor coil assembly and reinstalling coil as shown for left hand air supply. See Fig. 3-2

- Secondary drain pan kits are recommended when the unit is configured for the horizontal position over a finished ceiling and/or living space.

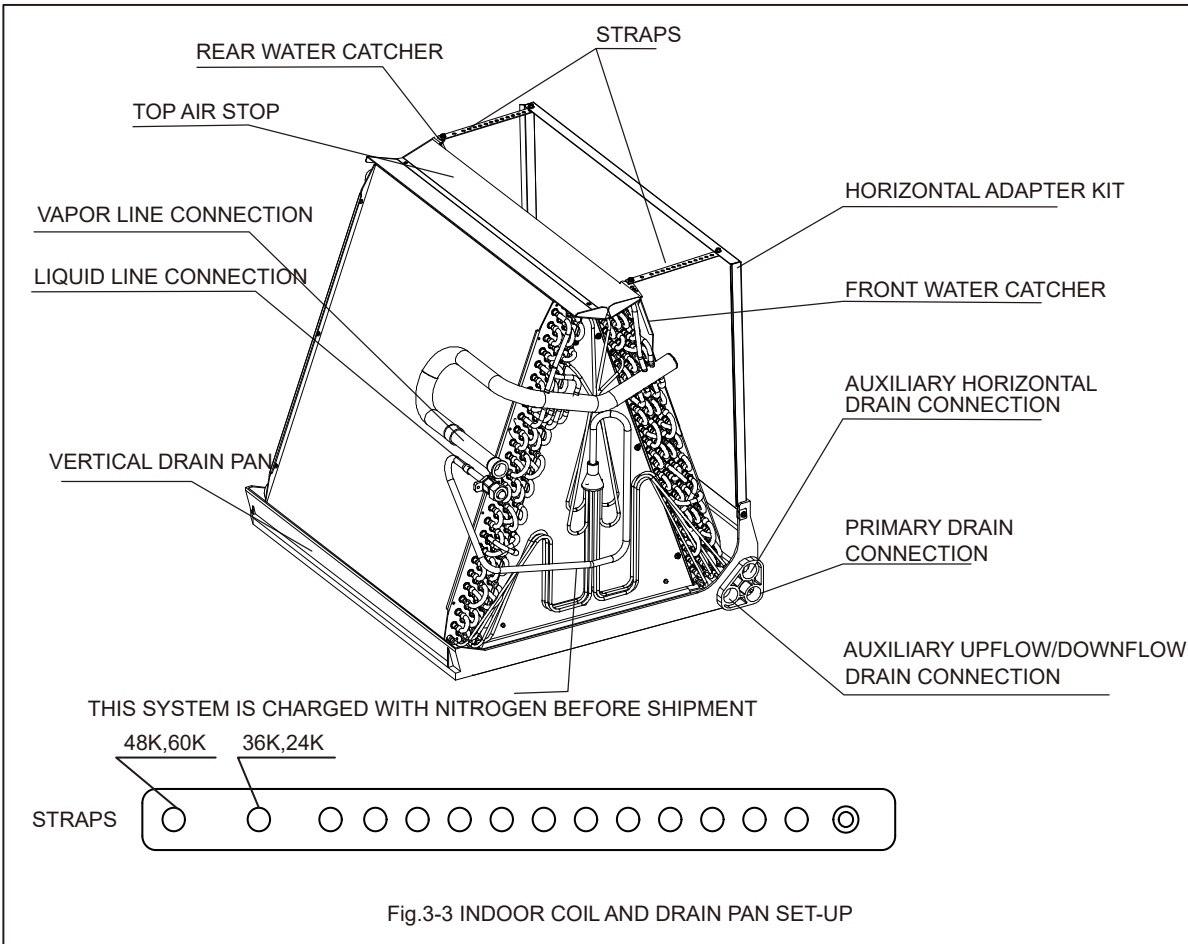
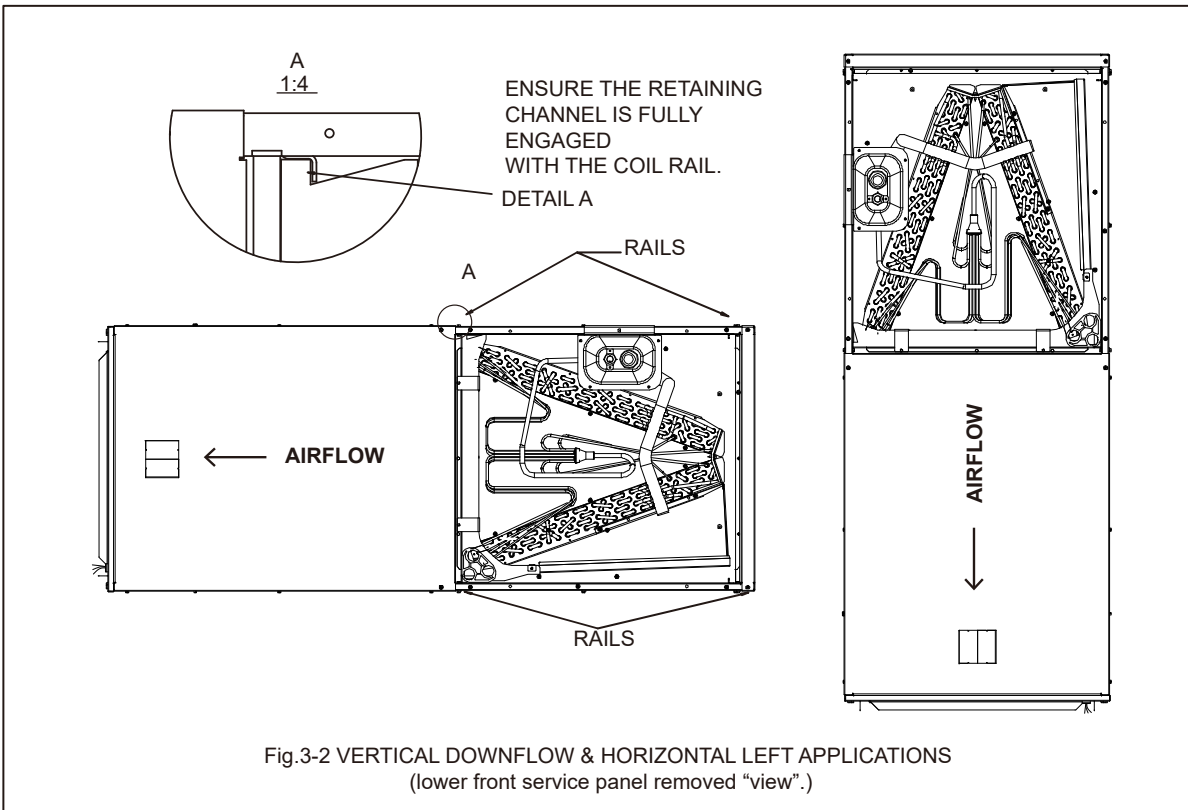

⚠ CAUTION

Horizontal units must be configured for right hand air supply or left hand air supply. Horizontal drain pan must be located under indoor coil. Failure to use the drain pan can result in property damage.

Conversion in Horizontal Direction: Horizontal right-hand supply can be changed to horizontal left-hand supply by removing the indoor coil and reinstalling 180° from original position.

3.4 Installation In An Unconditioned Space

IMPORTANT: There are two pairs of coil rails in the air handler for default and counter flow application. If the air handler is installed in an unconditioned space, the two unused coil rails should be removed to minimize air handler surface sweating. The coil rails can be easily removed by taking off the 6 mounting screws from both sides of the cabinet.

4. ELECTRICAL WIRING

Field wiring must comply with the National Electric Code (C.E.C. in Canada) and any applicable local ordinance.

⚠ WARNING

Disconnect all power to unit before installing or servicing. More than one disconnect switch may be required to de-energize the equipment. Hazardous voltage can cause severe personal injury or death.

4.1 Power Wiring

It is important that proper electrical power is available for connection to the unit model being installed. See the unit nameplate, wiring diagram and electrical data in the installation instructions.

- If required, install a branch circuit disconnect of adequate size, located within sight of, and readily accessible to the unit.
- **IMPORTANT:** After the Electric Heater is installed, units may be equipped with one two or three 30-60 amp. circuit breakers. These breaker(s) protect the internal wiring in the event of a short circuit and serve as a disconnect. Circuit breakers installed within the unit do not provide over-current protection of the supply wiring and therefore may be sized larger than the branch circuit protection.
- Supply circuit power wiring must be 167°C/75°C minimum copper conductors only. See Electrical Data in this section for ampacity, wire size and circuit protector requirement. Supply circuit protective devices may be either fuses or "HACR" type circuit breakers.

- Power wiring may be connected to either the right, left side or top. Three 7/8", 1-3/8", 1-3/4" dia. concentric knockouts are provided for connection of power wiring to unit.
- Power wiring is connected to the power terminal block in unit electric cabinet.

4.2 Control Wiring

IMPORTANT: Class 2 low voltage control wiring should not be run in conduit with main power wiring and must be separated from power wiring, unless class 1 wire of proper voltage rating is used.

- Low voltage control wiring should be 18 Awg. color-coded. For lengths longer than 100 ft., 16 Awg. wire should be used.
- Low voltage control connections are made to low voltage pigtails extending from top of air handler (upflow position - see Fig 2-5).
- Connections for control wiring are made with wire nuts. Control wiring knockouts (5/8" and 7/8") are also provided on the right and left side of the unit for side connection.
- See wiring diagrams attached to indoor and outdoor sections to be connected.
- Make sure, after installation, separation of control wiring and power wiring has been maintained.

4.3 Grounding

⚠ WARNING

The unit must be permanently grounded. Failure to do so can result in electrical shock causing personal injury or death.

- Grounding may be accomplished by grounding metal conduit when installed in accordance with electrical codes to the unit cabinet.
- Grounding may also be accomplished by attaching ground wire(s) to ground lug(s) provided in the unit wiring compartment.
- Ground lug(s) are located close to wire entrance on left side of unit (up-flow). Lug(s) may be moved to marked locations near wire entrance on right side of unit (up-flow). If alternate location is more convenient.
- Use of multiple supply circuits require grounding of each circuit to lug(s) provided in unit.

4.4 Electrical Data

MODEL	VOLTAGE	HERTZ	HP	SPEEDS	CIRCUIT AMPS.	MAXIMUM CIRCUIT PROTECTOR
24	208/230	60	1/5	3	2.6	15(A)
36	208/230	60	1/3	3	3.2	15(A)
48	208/230	60	1/2	3	4.3	15(A)
60	208/230	60	3/4	3	4.4	15(A)

4.5 Heat Kit Data

Heater Kit Model Used	Air Handler Model	Electric Heat (kW)	Min. Circuit Ampacity		Max. Fuse or Breaker (HACR) Ampacity		Fan speed (AC/HP)		
			240V	208V	240V	208V	Low	Medium	High
EHK-05A	24	5	29	25.5	30	30	●	●	●
EHK-08A		7.5	42	36.8	45	40	●	●	●
EHK-10A		10	55	48.1	60	50	●	●	●
EHK-05A	36	5	29.4	25.9	30	30	●	●	●
EHK-08A		7.5	42.4	37.2	45	40	●	●	●
EHK-10A		10	55.4	48.5	60	50	●	●	●
EHK-15B	48	15	55.4/26.1	48.5/22.6	60/30	50/25	●	●	●
EHK-20B		20	55.4/52.1	48.5/45.2	60/60	60/50	●	●	●
EHK-05A		5	30.3	26.8	35	30	--	--	●
EHK-08A	60	7.5	43.3	38.1	45	40	--	--	●
EHK-10A		10	56.3	49.4	60	50	--	--	●
EHK-15B		15	56.3/26.1	49.4/22.6	60/30	50/25	--	--	●
EHK-20B	60	20	56.3/52.1	49.4/45.2	60/60	50/50	--	--	●
EHK-05A		5	31.8	28.3	35	30	●	●	●
EHK-08A		7.5	44.8	39.6	45	40	●	●	●
EHK-10A	60	10	57.8	50.9	60	60	●	●	●
EHK-15B		15	57.8/26.1	50.9/22.6	60/30	60/25	●	●	●
EHK-20B		20	57.8/52.1	50.9/45.2	60/60	60/50	●	●	●

Heat kit suitable for AHU 4-way position installation.

Ampacities for MCA and Fuse/breaker including the blower motor.

Heat pump systems require a specified airflow. Each ton of cooling requires between 350 and 450 cubic feet of air per minute (CFM), or 400 CFM nominally.

Electric Heater Kits

NO.	Kit	Description	Ref. Air Handler Use
1	EHK-05A	5kW Heat Strip	24/36/48/60
2	EHK-08A	7.5kW Heat Strip	24/36/48/60
3	EHK-10A	10kW Heat Strip	24/36/48/60
4	EHK-15B	15kW Heat Strip, double Breaker panel	36/48/60
5	EHK-20B	20kW Heat Strip, double Breaker panel	36/48/60

5. AIRFLOW PERFORMANCE

Airflow performance data is based on cooling performance with a coil and no filter in place. Select performance table for appropriate unit size.

External static applied to unit allows operation within the minimum and maximum limits shown in table below for both cooling and electric heat operation.

AIRFLOW PERFORMANCE DATA

Model Number	Motor Speed		CFM Wet Coil without filter and Electric Heat								
			External Static Pressure-Inches W.C.[kPa]								
			0[0]	0.1[.025]	0.2[.050]	0.3[.075]	0.4[0.100]	0.5[0.125]	0.6[0.150]	0.7[0.175]	0.8[0.200]
24	Low	CFM	999	953	905	847	757	681	610	543	411
		Watts	316	310	306	302	288	279	270	256	240
		Current/A	1.38	1.36	1.34	1.32	1.28	1.24	1.21	1.16	1.1
	Medium	CFM	1176	1127	1086	1028	944	842	746	668	569
		Watts	342	336	334	326	315	303	292	281	266
		Current/A	1.49	1.47	1.45	1.42	1.38	1.33	1.29	1.25	1.19
	High	CFM	1409	1359	1306	1253	1192	1108	986	870	743
		Power/W	456	446	438	429	419	404	384	368	348
		Current/A	2.01	1.96	1.93	1.9	1.86	1.8	1.73	1.67	1.61
36	Low	CFM	1028	985	930	859	781	712	649	571	468
		Watts	362	353	345	335	323	313	303	290	276
		Current/A	1.64	1.62	1.6	1.57	1.54	1.51	1.49	1.45	1.42
	Medium	CFM	1315	1266	1208	1146	1065	981	866	775	686
		Watts	406	399	392	385	372	361	344	331	320
		Current/A	1.82	1.8	1.78	1.75	1.72	1.69	1.65	1.62	1.59
	High	CFM	1532	1478	1421	1347	1284	1184	1082	932	805
		Power/W	524	513	502	491	478	462	446	423	407
		Current/A	2.39	2.36	2.34	2.31	2.28	2.23	2.2	2.14	2.11
48	Low	CFM	1336	1310	1282	1234	1182	1140	1049	925	833
		Watts	492	483	474	463	452	443	422	393	374
		Current/A	2.24	2.22	2.17	2.13	2.1	1.93	2.03	1.9	1.87
	Medium	CFM	1654	1610	1569	1510	1461	1394	1350	1265	1034
		Watts	550	537	526	512	503	489	475	458	416
		Current/A	2.4	2.38	2.35	2.32	2.3	2.18	2.16	2.08	2.04
	High	CFM	1918	1875	1817	1771	1715	1651	1584	1511	1395
		Power/W	717	703	686	670	652	635	617	600	570
		Current/A	3.2	3.18	3.14	3.1	3.04	3	2.9	2.87	2.85
60	Low	CFM	1726	1693	1655	1637	1584	1500	1421	1328	1217
		Watts	678	658	639	619	602	576	553	526	495
		Current/A	2.95	2.87	2.78	2.69	2.62	2.52	2.42	2.31	2.18
	Medium	CFM	1983	1933	1879	1828	1760	1685	1597	1507	1403
		Watts	695	675	655	635	615	596	574	550	522
		Current/A	3.02	2.93	2.85	2.76	2.67	2.59	2.5	2.4	2.28
	High	CFM	2138	2086	2024	1952	1873	1797	1722	1646	1516
		Power/W	793	773	751	726	702	679	658	638	604
		Current/A	3.45	3.7	3.27	3.17	3.06	2.97	2.88	2.79	2.65

--- Shaded boxes represent airflow outside the required 300-450 cfm/ton, which are not recommended.

NOTES: Airflow based upon cooling performance at 230V with no electric heat and no filter.

The air distribution system has the greatest effect on airflow. The duct system is totally controlled by the contractor. For this reason, the contractor should use only industry-recognized procedures.

Heat pump systems require a specified airflow for electric heat operating. Each ton of cooling requires between 350 and 450 cubic feet of air per minute (CFM), or 400 CFM nominally.

Duct design and construction should be carefully done. System performance can be lowered dramatically through bad planning or workmanship.

Air supply diffusers must be selected and located carefully. They must be sized and positioned to deliver treated air along the perimeter of the space. If they are too small for their intended airflow, they become noisy. If they are not located properly, they cause drafts. Return air grilles must be properly sized to carry air back to the blower. If they are too small, they also cause noise.

The installers should balance the air distribution system to ensure proper quiet airflow to all rooms in the home. This ensures a comfortable living space.

An air velocity meter or airflow hood can be used to balance and verify branch and system airflow (CFM).

6. DUCTWORK

Field ductwork must comply with the National Fire Protection Association NFPA 90A, NFPA 90B and any applicable local ordinance.

⚠ WARNING

Do not, under any circumstances, connect return ductwork to any other heat producing device such as fireplace insert, stove, etc. Unauthorized use of such devices may result in fire, carbon monoxide poisoning, explosion, personal injury or property damage.

Sheet metal ductwork in unconditioned spaces must be insulated and covered with a vapor barrier. Fibrous ductwork may be used if constructed and installed in accordance with SMACNA Construction Standard on Fibrous Glass Ducts. Ductwork must comply with National Fire Protection Association as tested by UL Standard 181 for Class I Air Ducts. Check local codes for requirements on ductwork and insulation.

- Duct system must be designed within the range of external static pressure the unit is designed to operate against. It is important that the system airflow be adequate. Make sure supply and return ductwork, grills, special filters, accessories, etc. are accounted for in total resistance. See airflow performance tables in this manual.
- Design the duct system in accordance with "ACCA" Manual "D" Design for Residential Winter and Summer Air Conditioning and Equipment Selection. Latest editions are available from: "ACCA" Air Conditioning Contractors of America, 1513 16th Street, N.W., Washington, D.C. 20036. If duct system incorporates flexible air duct, be sure pressure drop information (straight length plus all turns) shown in "ACCA" Manual "D" are accounted for in the system.
- Supply plenum is attached to the 3/4" duct flanges supplied with the unit. Attach flanges around the blower outlet.

IMPORTANT: If an elbow is included in the plenum close to the unit, it can not be smaller than the dimensions of the supply duct flange on the unit.

IMPORTANT: The front flange on the return duct if connected to the blower casing must not be screwed into the area where the power wiring is located. Drills or sharp screw points can damage insulation on wires located inside unit.

- Secure the supply and return ductwork to the unit flanges, using proper fasteners for the type of duct used and tape the duct-to-unit joint as required to prevent air leaks.

7. REFRIGERANT CONNECTIONS

Keep the coil connections sealed until refrigerant connections are made. See the Installation Instructions for the outdoor unit for details on line sizing, tubing installation, and charging information.

Coil is shipped with Nitrogen. Evacuate the system before charging with refrigerant.

Install refrigerant tubing so that it does not block service access to the front of the unit.

Nitrogen should flow through the refrigerant lines while brazing.

Use a brazing shield to protect the cabinet's paint and a wet rag to protect the rubber grommet and input pipe's Piston seal ring from being damaged by torch flames.

After the refrigerant connections are made, seal the gap around the connections with pressure sensitive gasket.

⚠ WARNING

Use a wet rag to protect the two seal rings in the input pipe from being damaged by torch flames while brazing.

After the work is finished, make sure to check that there is no vapor leak after checking for vapor leaks, be sure to insulate the piping connections referring to Fig.7-1.

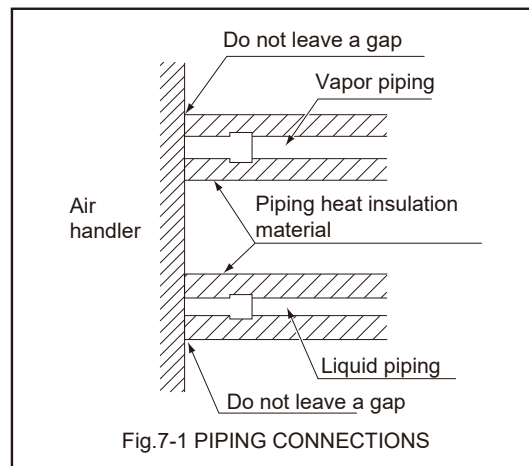

7.1 Condensate Drain Tubing

Consult local codes for specific requirements.

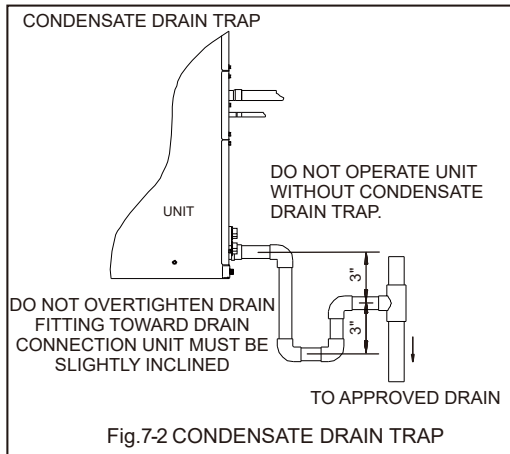

IMPORTANT:

1. When making drain fitting connections to the drain pan, use a thin layer of Teflon paste, silicone or Teflon tape and install, hand tighten.
2. When making drain fitting connections to drain pan, do not overtighten. Over tightening fittings can split pipe connections on the drain pan.

- Install drain lines so they do not block service access to front of the unit. Minimum clearance of 24 inches is required for filter, coil or blower removal and service access.
- Make sure unit is level or pitched slightly toward primary drain connection so that water will drain completely from the pan. (See Fig.7-2)
- Do not reduce drain line size less than connection size provided on condensate drain pan. Use 3/4" PVC piping for drain piping connections.
- All drain lines must be pitched downward away from the unit a minimum of 1/8" per foot of line to ensure proper drainage.
- Do not connect condensate drain line to a closed or open sewer pipe. Run condensate to an open drain or run line to a safe outdoor area.
- The drain line should be insulated where necessary to prevent sweating and damage due to condensate forming on the outside surface of the line.
- Make provisions for disconnecting and cleaning of the primary drain line should it become necessary. Install a 3 inch trap in the primary drain line as close to the unit as possible. Make sure that the top of the trap is below connection to the drain pan to allow complete drainage of pan. (See Fig. 7-2).
- Auxiliary drain line should be run to a place where it will be noticeable if it becomes operational. Homeowner should be warned that a problem exists if water should begin running from the auxiliary drain line.
- Plug the unused drain connection with the plugs provided in the parts bag, using a thin layer of teflon paste, silicone or teflon tape to form a water tight seal.

- Test condensate drain pan and drain line after installation is complete. Pour water into drain pan, enough to fill drain trap and line. Check to make sure drain pan is draining completely, no leaks are found in drain line fittings, and water is draining from the termination of the primary drain line.
- Be sure to insulate the drain piping and drain socket since condensation may cause water leakage.
- Be sure to install a drain trap at the drain outlet since the inside of the unit is at negative pressure relative to atmospheric pressure during operation.

8. AIR FILTER (not factory-installed)

External filter or other means of filtration is required. Units should be sized for a maximum of 300 feet/min air velocity or what is recommended for the type of filter installed.

Filter application and placement are critical to airflow, which may affect the heating and cooling system performance. Reduced airflow can shorten the life of the system's major components, such as motor, limits, elements, heat relays, evaporator coil or compressor. Consequently, we recommend that the return air duct system have only one filter location. For systems with a return air filter grill or multiple filter grills, can have a filter installed at each of the return air openings.

If adding high efficiency filters or electronic air filtration systems, it is very important that the air flow is not reduced. If air flow is reduced the overall performance and efficiency of the unit will be reduced. It is strongly recommended that a professional installation technician is contacted to ensure installation of these such filtration systems are installed correctly.

IMPORTANT: Do not double filter the return air duct system. Do not filter the supply air duct system. This will change the performance of the unit and reduce airflow.

⚠ WARNING

Do not operate the system without filters. A portion of the dust entrained in the air may temporarily lodge in the duct and run at the supply registers. Any circulated dust particles could be heated and charred by contact with the air handler heating elements. This residue could soil ceilings, walls, drapes, carpets and other articles in the house. Soot damage may occur with filters in place, when certain types of candles, oil lamps or standing pilots are burned.

9. FILTER INSTALLATION DIMENSIONS

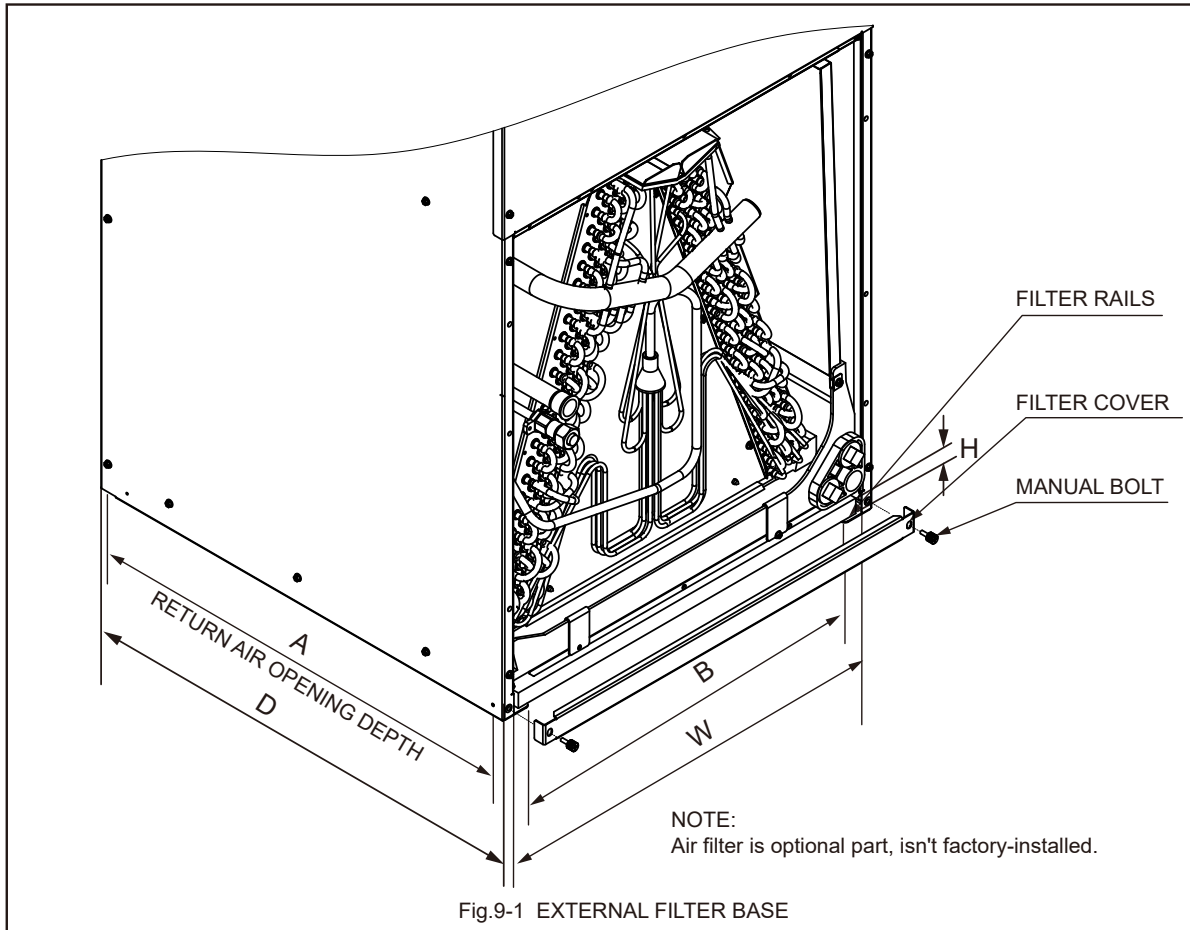

Fig.9-1 EXTERNAL FILTER BASE

DIMENSIONAL DATA

MODEL	FILTER SIZE IN [mm]	"W" IN [mm]	"D" IN [mm]	"H" IN [mm]	Return width "A" IN	Return length MODEL "B" IN
24/36	18X20[457X508]	18.3[466]	21.6[548]	1[25.4]	20.8	16.3
48/60	20X22[508X559]	20.7[526]	23.9[608]	1[25.4]	23	18.8

AIR FILTER REMOVAL

1. Remove bolts manually, remove air filter recover. See in Fig.9-1.
2. Hold the edge of the air filter and extract out.
3. Clean the air filter (Vacuum cleaner or pure water may be used to clean the air filter. If the dust accumulation is too heavy, use soft brush and mild detergent to clean it and dry out in cool place). See in Fig.9-2.
4. Install new filter so that the arrow on the filter is in the same direction as airflow.

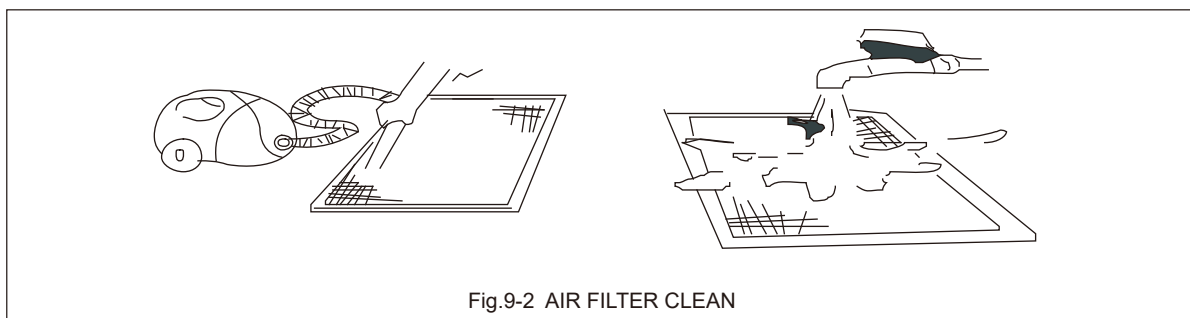
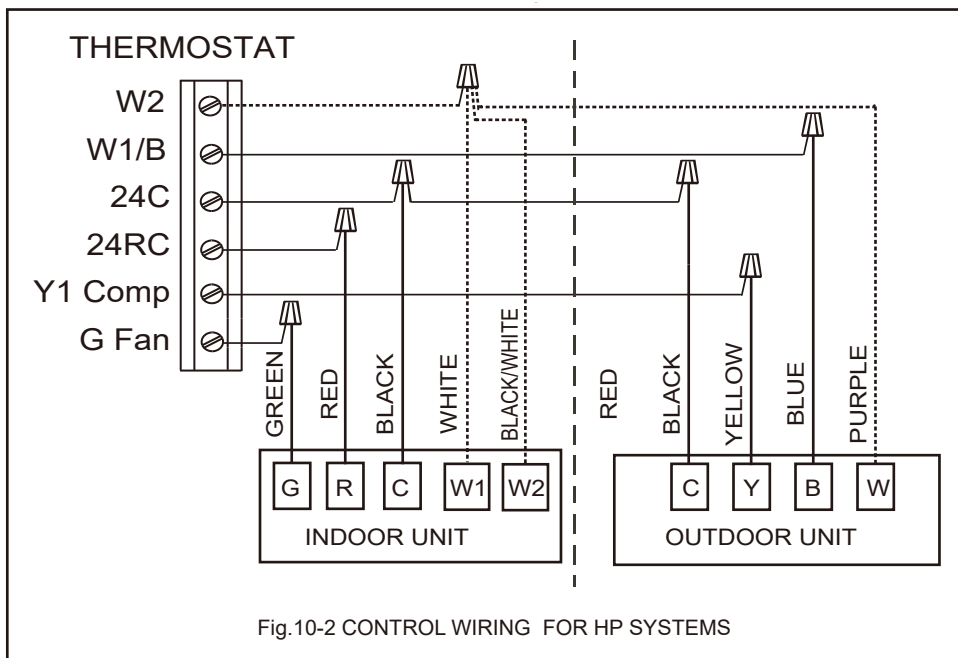
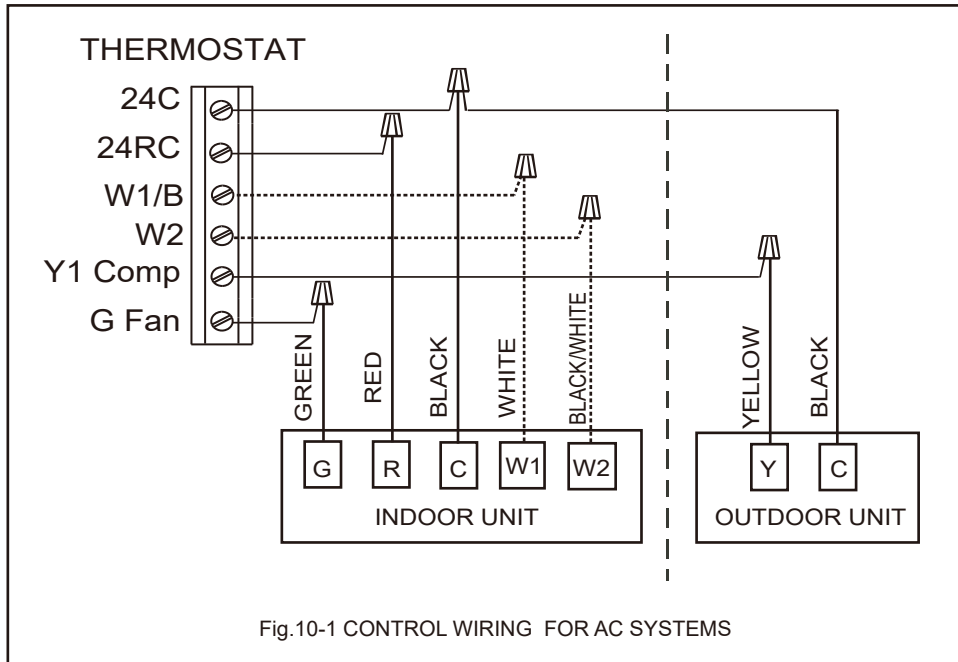
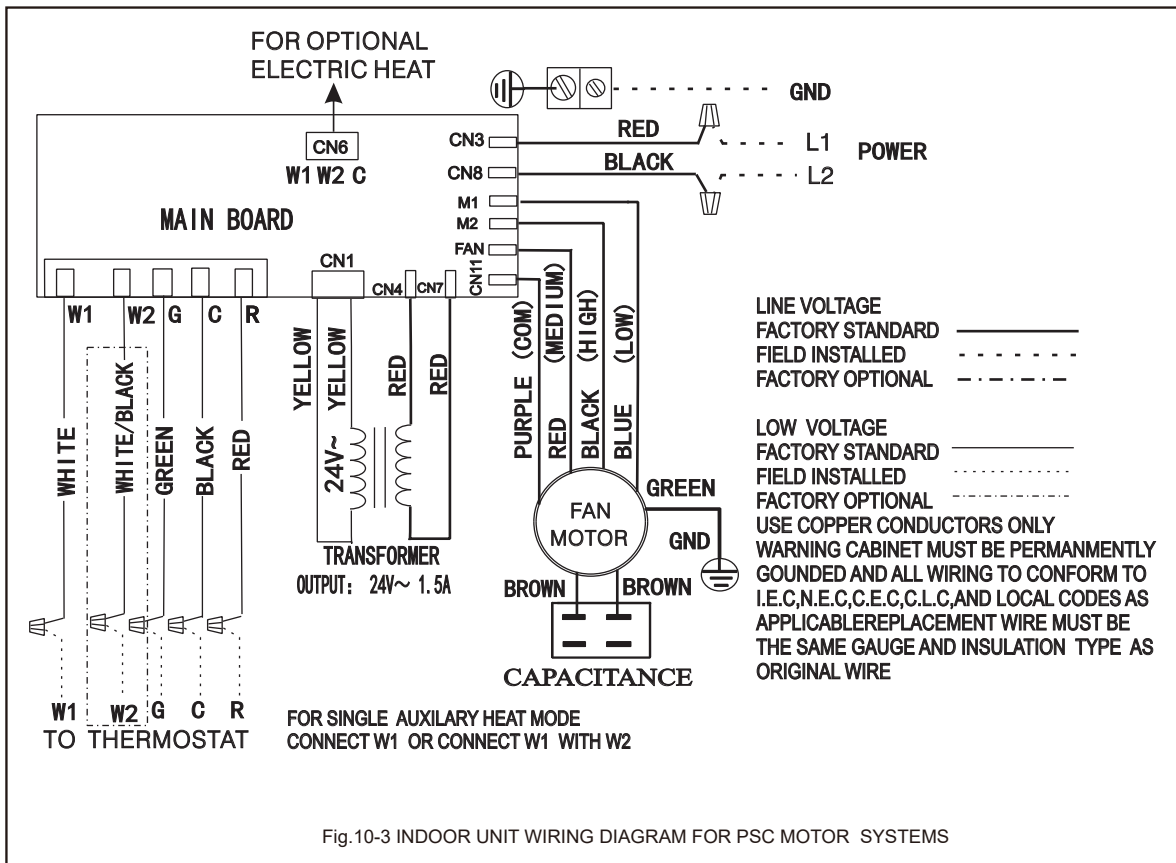

Fig.9-2 AIR FILTER CLEAN

10. WIRING DIAGRAM



WARNING HIGH VOLTAGE!
 DISCONNECT ALL POWER BEFORE SERVICING OR INSTALLING THIS UNIT. MULTIPLE POWER SOURCES MAY BE PRESENT. FAILURE TO DO SO MAY CAUSE PROPERTY DAMAGE, PERSONAL INJURY OR DEATH.



Note: Description of fan speed switch with PSC motor

1. Default as medium speed of factory settings.
2. High speed wiring: Switch to high speed (black wire) and connect with FAN terminal, while medium speed (red wire) connect with M2 terminal.
3. Low speed wiring: Switch to low speed (blue wire) and connect with FAN terminal, while medium speed (red wire) connect with M1 terminal.
4. For the 36K model, in order to make the AHRI 14.3 SEER2 system rating the fan speed must be changed from Medium to High.

Terminal / Fan speed	Fan	M1	M2
Medium	Red	Blue	Black
High	Black	Blue	Red
Low	Blue	Red	Black

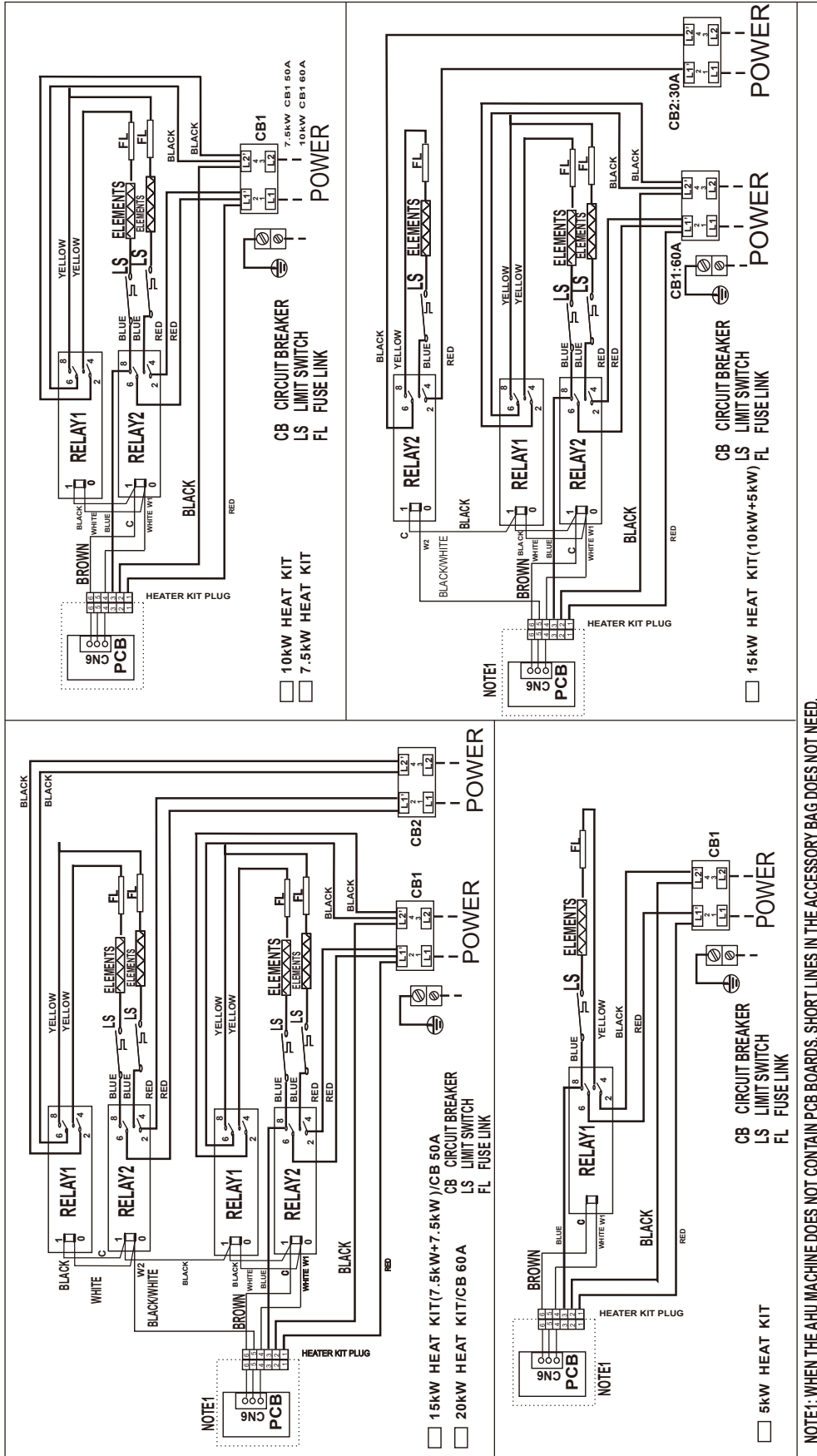

Fig.10-4 INDOOR UNIT WIRING DIAGRAM FOR ELECTRIC HEAT

Wiring is subject to change. Always refer to the wiring diagram on the unit for the most up-to-date wiring.

11. PISTON/TXV INSTALLATION

This coil comes with a factory installed piston metering device. See Table 11-1 for factory installed piston size. Some system combinations will require a different sized piston to be field installed.

A TXV may be required to achieve minimum efficiency ratings or for long refrigerant line set applications. Reference AHRI for system combination ratings.

Reference Table 11-3 to charge the system by superheat when using a piston. Reference the outdoor unit installation guide to change the system by subcooling when using a TXV.

Table 11-1. Factory installed piston size for each model. Additional piston sizes are provided in the ship with literature bag as necessary.

MODEL	50	52	56	58	60	64	68	70	73	75	80	83	90
24				X*									
36					X			X	X*				
48										X		X*	
60													X*

* means that this piston is pre-installed

WARNING

Failure to install the proper piston can lead to poor system performance and possible compressor damage.

Table 11-2 . Optional TXV kit part numbers. Some combinations may require a TXV. See AHRI for system combination ratings.

Outdoor Unit Capacity (Tons)	R410a TXV Kit
1.5-3.0	TR6-3TONNB
3.5-4.0	TR6-4TONB
5.0	TR6-5TONB

Table 11-3.Superheat Charging Chart

Charge the system by superheat when using a piston. Reference the outdoor unit installation guide to charge the system by subcooling when using a TXV.

Outdoor Temp (°F)	Indoor Temperature(°F) Dry Bulb/wet Bulb					
	95/79	90/75	85/71	80/67	75/63	70/58
	Superheat (°F)					
115	23	16	7	6	5	5
110	24	17	9	6	5	5
105	26	19	11	6	5	5
100	27	21	13	7	6	5
95	29	23	14	9	6	5
90	30	25	18	12	7	5
85	32	26	20	15	9	6
80	34	28	22	17	11	6
75	35	30	24	19	13	7
70	37	32	26	21	16	10
65	38	34	29	24	19	13
60	40	36	31	27	22	17
55	41	37	34	30	26	21



SE SERIES LIMITED WARRANTY

Congratulations on purchasing your new HVAC equipment.

Your unit automatically qualifies for the warranty coverage listed below provided you meet the warranty conditions.

YEAR 1 PRODUCT REPLACEMENT

If the heat exchanger, evaporator coil (packaged systems only), condenser coil, or compressor fails within the first year (365 days) after the date of installation to the original consumer for the original installation, the original purchase cost of the unit will be reimbursed to the authorized Comfort-Aire/Century distributor who has received prior authorization from Comfort-Aire/Century for the failure. The owner is responsible for additional labor, freight, and miscellaneous charges. Units installed in a commercial application, defined as any application other than a residential/multifamily (personal, family or household) purpose, are not eligible for the one year product replacement.

LIMITED WARRANTY

All parts are warranted to be free from defects in workmanship and materials for normal residential use and maintenance for five (5) years from the date of purchase by the original consumer for the original residential installation. The compressor and the heat exchanger are warranted to be free from defects in workmanship and materials for normal residential use and maintenance for ten (10) years from the date of purchase by the original consumer for the original residential installation.

LIMITED EXTENDED WARRANTY

When registered with Comfort-Aire/Century, the heat exchanger is warranted to be free from defects in material and workmanship for twenty (20) years and all parts are warranted to be free from defects in material and workmanship for ten (10) years from the date of purchase by the original consumer for the original installation.

DURATION OF WARRANTY

The warranty begins on the date of purchase by the original consumer (homeowner). The original consumer must retain a receipted bill of sale or invoice showing model and serial number as proof of the warranty period initiation.

CONDITIONS FOR WARRANTY COVERAGE

Unit must be properly installed and maintained by a licensed HVAC service provider in accordance with the installation, operation, and maintenance instructions provided with each unit. Unit cannot have been subjected to accident, alteration, improper repair, neglect/misuse, or force majeure. Proof of proper maintenance over the lifetime of the unit must be supplied. Performance cannot be impaired by use of any product not authorized by Comfort-Aire/Century, or by any adjustments or adaptations to components. Serial numbers and/or rating plate have not been altered or removed. Damage has not been a result of inadequate wiring or voltage conditions, use during brown-out conditions, or circuit interruptions. Unit remains in the original residential installation and is not transferrable. Unit was not purchased over the internet or at auction. Non-approved refrigerant and/or non-approved system additives will void this warranty.

WARRANTY EXCEPTIONS

The Limited Express Warranty does not cover costs associated with normal maintenance, utility usage, labor, shipping and handling, or collateral damage. It also does not cover any portion or component of the system that is not supplied by Comfort-Aire/Century, regardless of the cause of failure of such portion or component.

LIMITATION OF LIABILITY

There are no other express or implied warranties. Comfort-Aire/Century makes no warranty of merchantability and does not warrant that the unit is suitable for any particular purpose, building, room size, or condition except as specifically provided in this document. There are no other warranties, express or implied, which extend beyond the description in this document. All warranties implied by law are limited in duration to the five-year term of the Parts Warranty. Your exclusive remedy is limited to the replacement of defective parts. Comfort-Aire/Century will not be liable for any consequential or incidental damages caused by any defect in this unit. This warranty gives you specific legal rights and you may also have other rights which vary from state to state. Some states do not allow a limitation on how long an implied warranty lasts or do not allow the exclusion or limitation of incidental or consequential damages, so the above limitations or exclusions may not apply to you. No warranties are made for units sold outside the continental United States and Canada. Your distributor or final seller may provide a warranty on units sold outside these areas. Comfort-Aire/Century will not be liable for damages if our performance regarding warranty resolution is delayed by events beyond our control including accident, alteration, abuse, war, government restrictions, strikes, fire, flood, or force majeure.



Please visit www.heatcontroller.com to register your new product.

KEEP THIS INFORMATION AS A RECORD OF YOUR PURCHASE

Apply Serial Number and Model Number sticker here (from product carton). If unavailable, write serial number and model number below (can be found on unit rating plate).

Date of Purchase _____

Date Installation Completed _____

Component of new HVAC system

Replacement furnace only

Remember to retain your bill of sale as proof of warranty period and ownership.

Page Intentionally Left Blank

Page Intentionally Left Blank

Page Intentionally Left Blank

Due to ongoing product improvements, specifications and dimensions are subject to change and correction without notice or incurring obligations. Determining the application and suitability for use of any product is the responsibility of the installer. Additionally, the installer is responsible for verifying dimensional data on the actual product prior to beginning any installation preparations.

Incentive and rebate programs have precise requirements as to product performance and certification. All products meet applicable regulations in effect on date of manufacture; however, certifications are not necessarily granted for the life of a product. Therefore, it is the responsibility of the applicant to determine whether a specific model qualifies for these incentive/rebate programs.

Comfort-Cire®  **Century**®