

VCD-Series

Enjoy the ultimate in comfort and efficiency with the VCD-Series extreme performance air source heat pump. With an inverter-driven compressor, the VCD-system fully modulates to use the least amount of energy possible to maintain temperature, while at the same time optimizing sound levels and comfort. Hyper heat performance down to -22°F (-30°C) and cooling to an extreme 122°F (50°C) means the heat pump has world-class operating parameters in all weather conditions. Available with auxiliary heat kits for the VCD air handler, or with the optional MCD-Series of cased coil for dual-fuel capabilities with any new or existing furnace.

FEATURES

- Aluminum-alloy traditional fin-and-tube coil construction for maximum durability and corrosion resistance
- Efficient and quiet ECM blower motor
- Accepts traditional 24VAC thermostats for convenience and advanced control options
- Wired programmable control included
- Optional electric resistance heat kits (up to 25kW) provides auxiliary heat source for comfort during the worst conditions
- Beautiful and durable gloss enameled-steel construction with insulated construction provides less than 2% cabinet leakage
- Built-in return filter rack:
18K & 24K = 16" x 20" x 1"
30-48K = 20" x 20" x 1"
60K = 24" x 20" x 1"
- Multi-position air handler



Wired programmable control



EXTREME PERFORMANCE HEAT PUMP

1.5 to 5 Tons

Six models to choose from
18,000 to 60,000 BTUH



COOLING

5°F (-15°C) – 122°F (50°C)

HEATING

-22°F (-30°C) – 75°F (24°C)

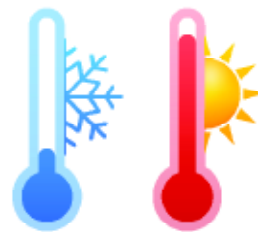

MULTI-POSITION AIR HANDLER

Ducted Units								
FEATURES			B-VCD18SA-1	B-VCD24SA-1	B-VCD30SA-1	B-VCD36SA-1	B-VCD48SA-1	B-VCD60SA-1
Power supply	Rated	V, Ph, Hz	208/230, 1, 60	208/230, 1, 60	208/230, 1, 60	208/230, 1, 60	208/230, 1, 60	208/230, 1, 60
	Voltage range	V	187-253	187-253	187-253	187-253	187-253	187-253
Cooling	Rated Capacity (range)	Btu/h	18,000 (6,880~21,000)	24,000 (6,400~27,000)	30,000 (10,000~33,600)	36,000 (13,000~47,400)	47,000 (15,000~48,000)	55,000 (14,000~56,000)
	Input power	W	1,450	2,050	3,060	3,673	5,731	6,280
	Rated current	A	6.4	9.10	13.20	15.97	24.95	27.40
	EER2	Btu/w	12.4	11.7	10.00	10.00	8.2	8.8
	SEER2	Btu/w	18	17.4	16.2	16	15.6	15.3
Heating at 47°	Rated Capacity (range)	Btu/h	19,000 (2,800~21,000)	24,000 (10,100~31,000)	33,000 (11,500~37,000)	40,000 (11,000~57,200)	50,000 (11,000~55,000)	55,000 (13,400~69,000)
	Input power	W	1,530	2,100	2,930	3,448	4,652	5,060
	Rated current	A	6.8	9.30	13.30	15.00	21.20	22.00
	COP	W/W	3.64	3.35	3.30	3.36	3.15	3.42
	HSPF4 2	Btu/w	9.3	10.00	8.9	9.5	9.4	9.4
Heating at 5° (-15°)	Capacity	Btu/h	16,500	24,130	28,550	38,890	47,060	51,981
	COP	W/W	2.04	1.91	1.77	1.97	1.90	1.91
The Rated Input Current of The Power Conversion Equipment		A	2.5	3.0	3.5	3.5	3.5	3.5
MINIMUM CIRCUIT AMPACITY (Indoor unit)		A	2.5	4.0	4.5	5.0	7.5	9.0
MAX. FUSE (Indoor unit)		A	15	15	15	15	15	15
Indoor air flow (Hi/Mi/Lo)		CFM	618/530/450	624/695/630	1,089/806/712	1,189/971/865	1,471/1,095/906	1,806/1,359/1,136
Indoor noise level (Hi/Mi/Lo)		dB(A)	34/31/30	39/36/33	42/40.5/36.5	45/43/41	50/47/43.5	51/45.5/41.5
Indoor unit	Dimension (W×D×H)	inch	21.02x17.52x45	21.02x17.52x45.00	21.02x21.02x49.02	21.02x21.02x49.02	21.02x21.02x49.02	21.02x24.49x52.99
	Packing (W×D×H)	inch	25.20x20.87x50.39	25.20x20.87x50.39	25.20x24.41x54.33	25.20x24.41x54.33	25.20x24.41x54.33	27.95x26.77x56.60
	Net/Gross weight	lbs.	105.82/129.41	105.60/127.43	129.19/155.64	129.19/155.64	130.51/156.31	162.70/190.70
Refrigerant piping	Liquid side/ Gas side	inch	3/8" / 3/4"	3/8" / 3/4"	3/8" / 3/4"	3/8" / 3/4"	3/8" / 3/4"	3/8 x 7/8
Drainage water pipe diameter		inch	3/4	3/4	3/4	3/4	3/4	3/4
Thermostat type	Wireless remote controller		Standard	Standard	Standard	Standard	Standard	Standard
	Wired Controller		n/a	n/a	n/a	n/a	n/a	n/a
	Programmable wired Controller		Standard	Standard	Standard	Standard	Standard	Standard

Auxiliary Heat Kits									
	Power of Electric Heater	Number of Circuits	Voltage	Circuit 1 MCA	Circuit 2 MCA	Circuit 3 MCA	Circuit 1 Max. Fuse	Circuit 2 Max. Fuse	Circuit 3 Max. Fuse
Optional Electric Heater	ECD3KW	1	208/230V	14A/16A	-	-	-	-	-
	ECD5KW	1	208/230V	23A/27A	-	-	-	-	-
	ECD8KW	1	208/230V	37A/42A	-	-	40A/45A	-	-
	ECD10KW	1	208/230V	46A/53A	-	-	50A/60A	-	-
	ECD15KW	2	208/230V	23A/27A	46A/53A	-	25A/30A	50A/60A	-
	ECD20KW	2	208/230V	46A/53A	46A/53A	-	50A/60A	50A/60A	-
	ECD25KW	3	208/230V	23A/27A	46A/53A	46A/53A	25A/30A	50A/60A	50A/60A

Model Size Selection							
Model (Btu/h)	3kW	5kW	8kW	10kW	15kW	20kW	25kW
8K	Yes	Yes	Yes	Yes	-	-	-
24K		Yes	Yes	Yes	Yes	-	-
30K		Yes	Yes	Yes	Yes	-	-
36K		Yes	Yes	Yes	Yes	Yes	-
48K			Yes	Yes	Yes	Yes	-
60K			-	Yes	Yes	Yes	Yes

Recommended Size of Filter

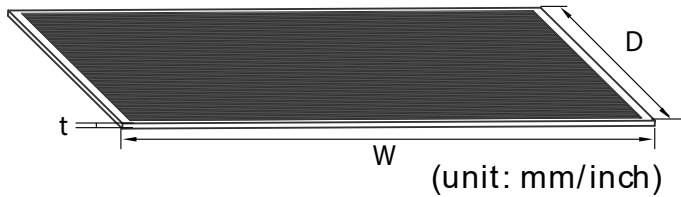

(unit: mm/inch)

Model (Btu/h)	W		D		T	
	mm	inch	mm	inch	mm	inch
18K	406.4	16	508	20	25.4	1
24K	406.4	16	508	20	25.4	1
30-48K	508	20	508	20	25.4	1
60K	609.6	24	508	20	25.4	1

DIMENSIONAL DRAWINGS

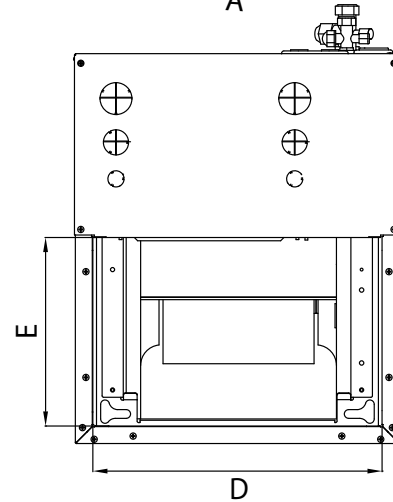
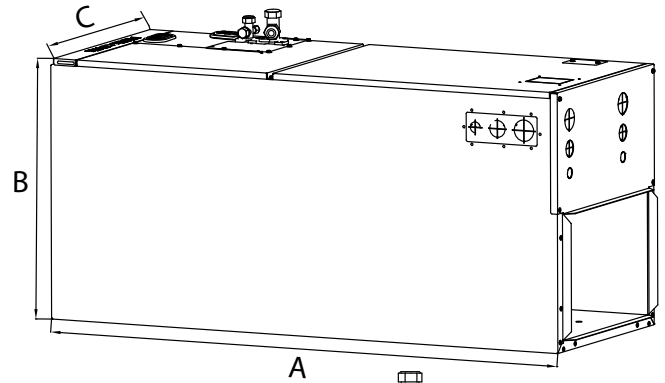

Dimensional Data

(unit: mm/inch)

Model (Btu/h)	Dimensions	18K	24K	30K~48K	60K
Length of A	mm	1,143	1,143	1,245	1,346
	inch	45	45	49	53
Length of B	mm	533	533	533	533
	inch	21	21	21	21
Length of C	mm	445	445	534	622
	inch	17-1/2	17-1/2	21-1/50	24-1/2
Length of D	mm	400	400	490	580
	inch	15-3/4	15-3/4	19-5/16	22-27-32
Length of E	mm	260	260	260	260
	inch	10-1/4	10-1/4	10-1/4	10-1/4

Vertical Installations

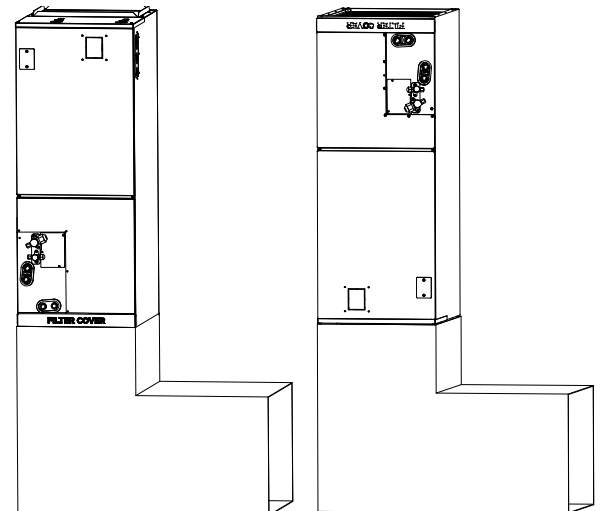

Horizontal Installations

Plenum Clearances

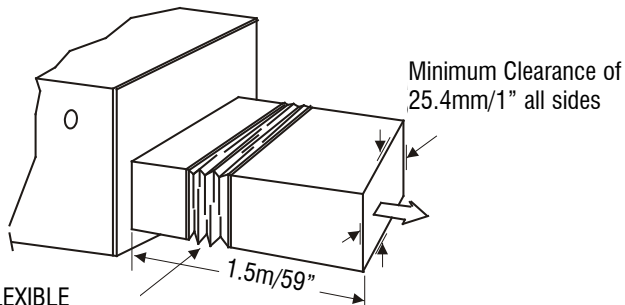

FLEXIBLE DUCT COLLAR

The outlet side pipe length is 1.5m/59".



DIMENSIONAL DRAWINGS

Model		MCD(18,24)B1A		MCD(30,36)B1A		MCD(30,36,48)C1A		MCD60D1A	
Dimensions		in.	mm.	in.	mm.	in.	mm.	in.	mm.
A	Model Height	18	457	23-1/2	599	24	609	28	711
B	Model Width	17-1/2	445	17-1/2	445	21	533	24-1/2	622
C	Supply Air Opening Width	16-3/16	411	16-3/16	411	19-3/4	502	23-1/4	591
D	Return Air Opening Width	15-1/8	384	15-1/8	384	19-1/2	496	23	585
E	Model Depth	21	533	21	533	21	533	21	533
F	Supply Air Opening Depth	18-5/8	473	18-5/8	473	18-5/8	473	18-5/8	473
G	Return Air Opening Depth	18	458	18	458	18-1/2	470	18-1/2	470
H	Supply Air Opening Side Clearance	5/8	16	5/8	16	5/8	16	5/8	16
I	Supply Air Opening Front Clearance	1-3/4	45	1-3/4	45	1-3/4	45	1-3/4	45
J	Return Air Opening Side Clearance	1-3/16	30	1-3/16	30	3/4	19	3/4	19
K	Return Air Opening Front Clearance	1-13/16	46	1-13/16	46	1-13/16	46	1-13/16	46
L	Condensate Drains Height	1-7/16	37	1-7/16	37	2-1/8	54	2-1/8	54
M	Liquid Line Height	10-7/8	276	16-1/2	418	16-5/16	414	20-1/4	514

NOTE: AHRI combinations with MCD-Series Coils and VCD systems are "coil-only" matches, and result in lower SEER2, EER2, and HSPF2 ratings than with matching air handler. Review latest match information on www.AHRIdirectory.org before installation.

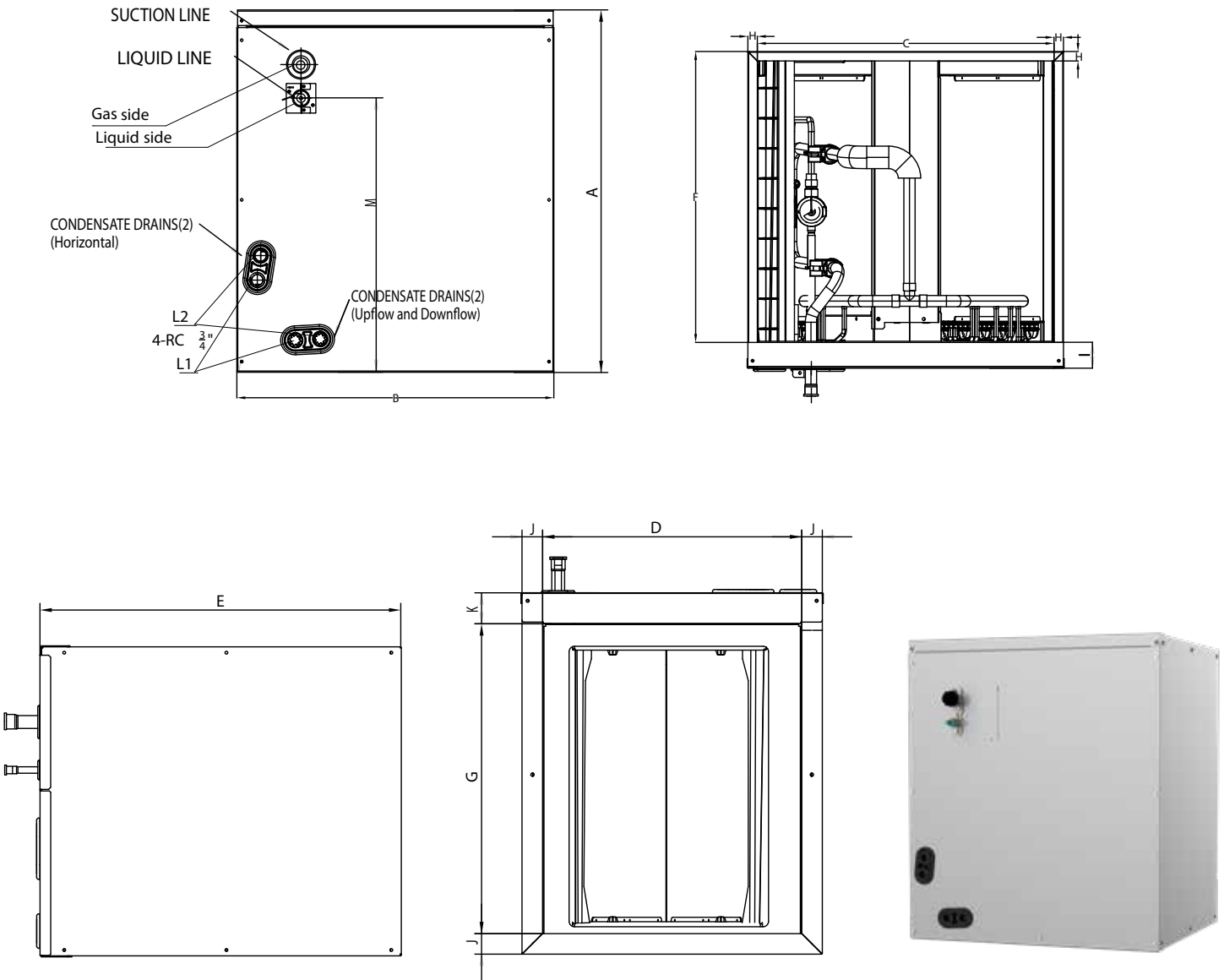

OUTDOOR UNIT

FEATURES	A-VCD18SA-1	A-VCD24SA-1	A-VCD30SA-1	A-VCD36SA-1	A-VCD48SA-1	A-VCD60SA-1
Power Supply	208/230V,1Ph,60Hz	208/230V,1Ph,60Hz	208/230V,1Ph,60Hz	208/230V,1Ph,60Hz	208/230V,1Ph,60Hz	208/230V,1Ph,60Hz
Cooling Capacity (BTUH)	18,000	24,000	30,000	36,000	47,000	55,000
SEER2	18.0	17.4	16.2	16	15.6	15.3
EER2	12.4	11.7	10.0	10.0	8.2	8.8
HSPF4 2	9.3	10	8.9	9.5	9.4	9.4
COP	3.64	3.35	3.30	3.36	3.15	3.42
Cooling Amps	6.4	9.10	13.20	15.97	24.95	27.40
Heating Cap. (BTUH) @ 47°F	19,000	24,000	33,000	40,000	50,000	59,000
Heating Amps	6.8	9.30	13.30	15.0	21.20	22.0
Outdoor DBA	57	62	60.5	64	64	63.5
OUTDOOR UNIT DIMENSIONS						
Width (inches)	35.04	37.24	37.24	37.48	37.48	37.48
Height (inches)	26.50	31.89	31.89	52.48	52.48	52.48
Depth (inches)	13.46	16.14	16.14	16.34	16.34	16.34
Net Wt/Shipping Wt (lbs.)	102.95/109.79	136.69/145.50	159.83/169.75	227.07/255.70	220.24/248.90	239.86/271.61
ELECTRICAL DATA OUTDOOR UNIT †						
Main Power Connection	Outdoor Unit 208/230-1-60					
Min. Circuit Ampacity	**16.0	**20.5	**23	**30	**40	**40
Max. Fuse/HACR Circuit Breaker	**20.0	**35	**35	**50	**50	**50
LINE SETS O.D. (inch)						
Line Sets O.D. (inch)*	3/8 x 3/4	3/8 x 3/4	3/8 x 3/4	3/8 x 3/4	3/8 x 3/4	3/8 x 7/8
Max. Line Set Length ¹	98.4	164	213	213	213	213
Max. Elevation (outdoor) ²	65.6	82	98	98	98	98

Note:

*For alternative line set sizes, please refer to the VCD Vapor Line Sizing Chart

† Always follow local, state and national electrical codes

¹ Min. 10 ft. line set recommended

² Oil traps should be installed every 16.5 to 23 feet (5-7m) when the outdoor unit is installed above the indoor unit

****Verify Rating Plate Information
Prior to Installation.**

Minimum Circuit Ampacity and Maximum Fuse Values
May Have Changed from Original Specifications.



DIMENSIONAL DRAWINGS

Outdoor Unit Dimensions - 18K & 24K

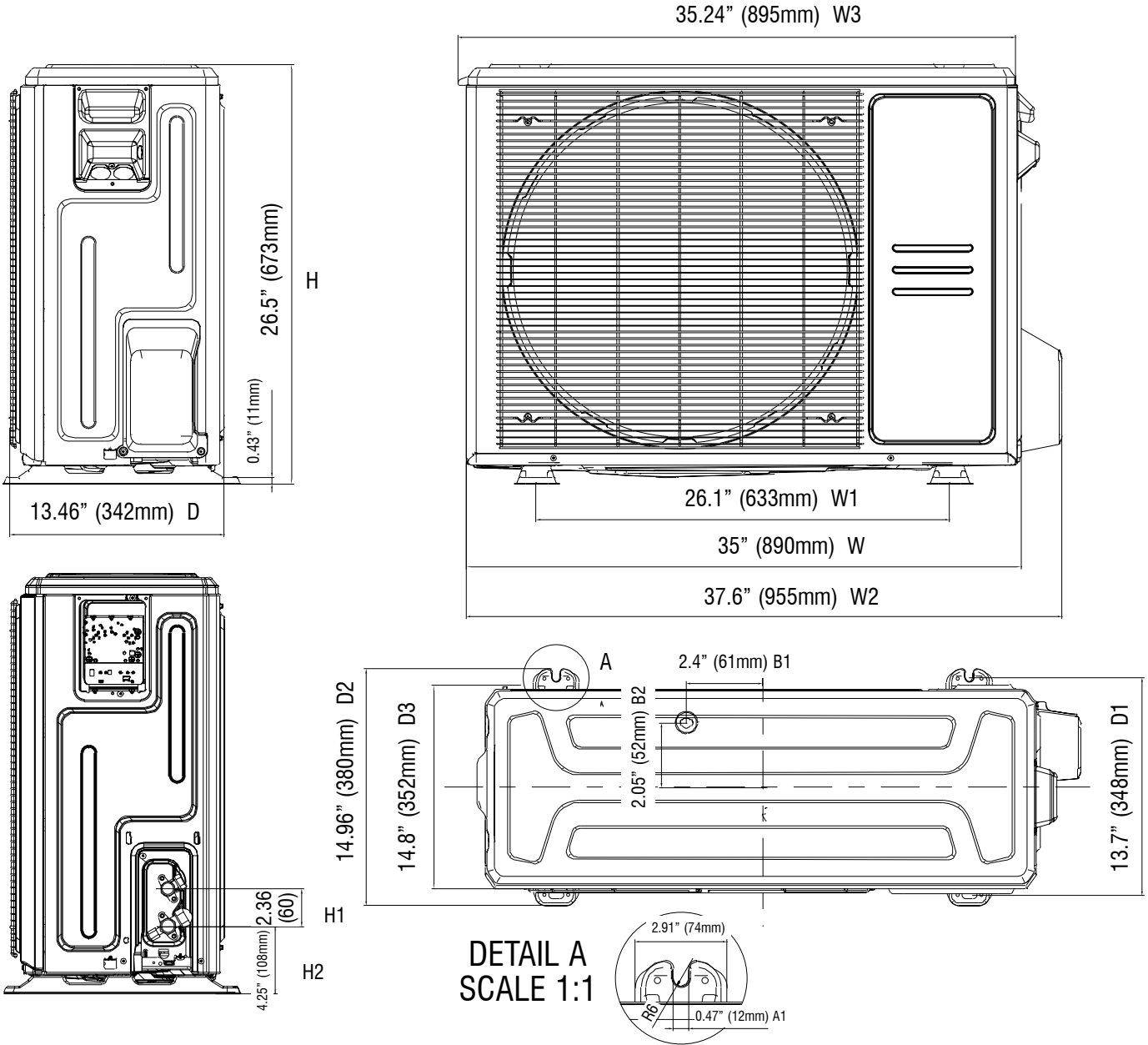

DIMENSIONAL DRAWINGS

Outdoor Unit Dimensions - 30, 36, & 48K

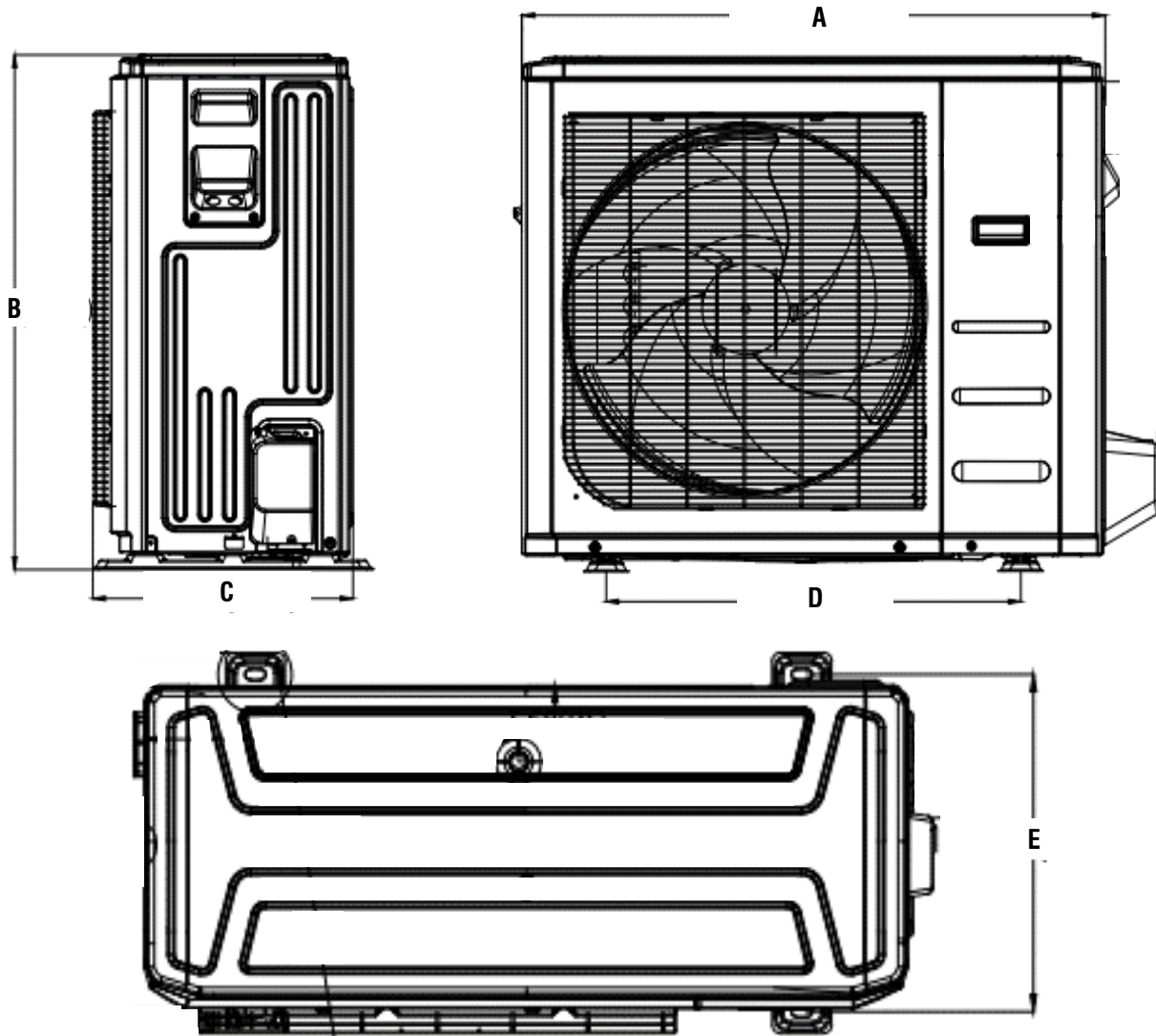

Model	FEATURES	A-VCD30SA-1	A-VCD36SA-1	A-VCD48SA-1
A	Width (inches)	37.24" (946mm)	38.58" (980mm)	38.58" (980mm)
B	Height (inches)	31.89" (810mm)	38.39" (975mm)	38.39" (975mm)
C	Depth (inches)	16.14" (410mm)	16.34" (415mm)	16.34" (415mm)
D	Mounting Width (inches)	26.50" (673mm)	24.01" (610mm)	24.01" (610mm)
E	Mounting Depth (inches)	15.88" (403mm)	15.01" (381mm)	15.01" (381mm)

DIMENSIONAL DRAWINGS

Outdoor Unit Dimensions - 60K

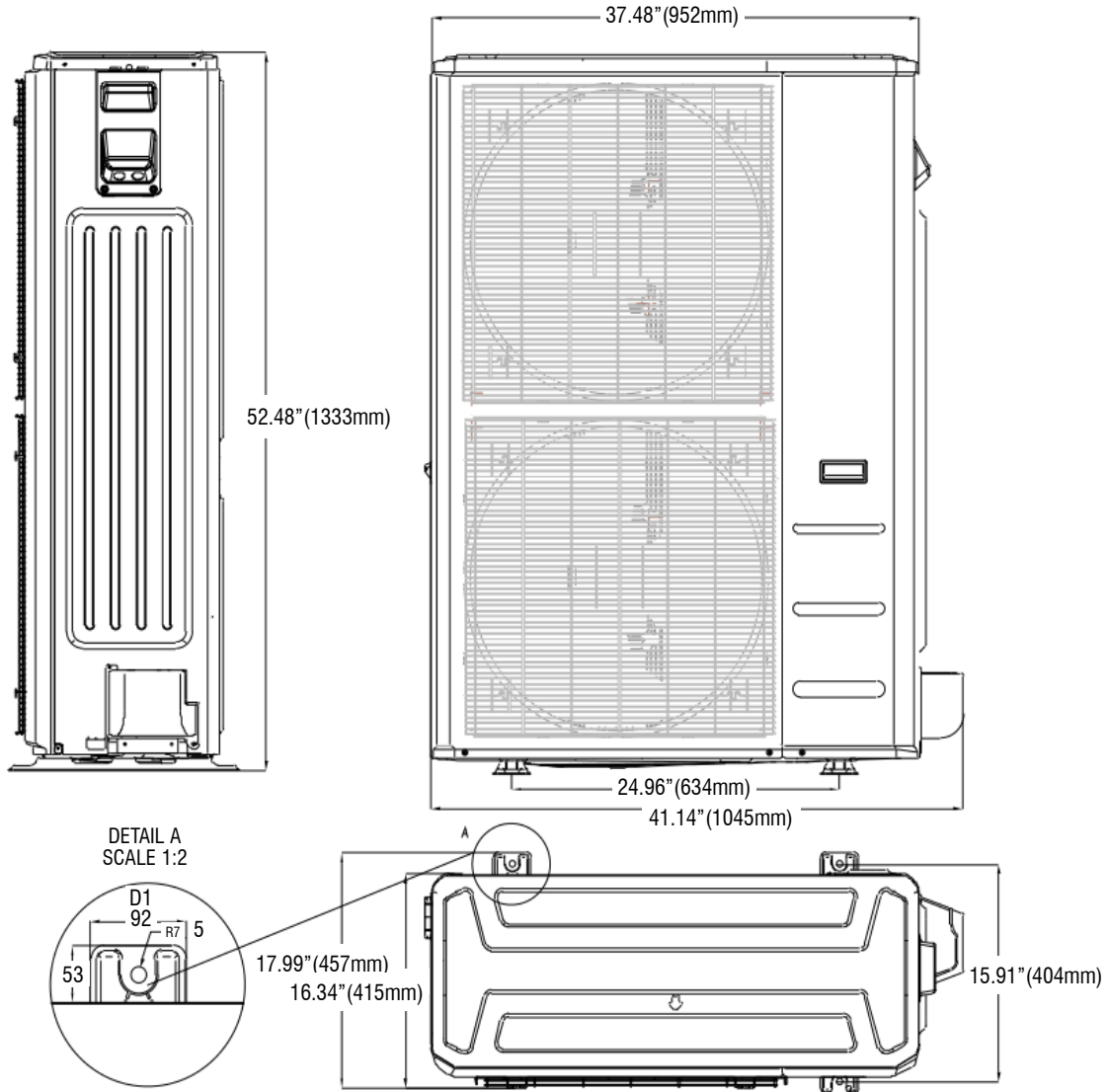

Due to ongoing product improvements, specifications and dimensions are subject to change and correction without notice or incurring obligations. Determining the application and suitability for use of any product is the responsibility of the installer. Additionally, the installer is responsible for verifying dimensional data on the actual product prior to beginning any installation preparations. Third party incentive and rebate programs have precise requirements as to product performance and certification. All products meet applicable regulations in effect on date of manufacture; however, certifications are not necessarily granted for the life of a product. Therefore, it is the responsibility of the applicant to determine whether a specific model qualifies for these incentive/rebate programs.

"This product complies with all California product labeling laws including, but not limited to, the Safe Drinking Water and Toxic Enforcement Act of 1986, more commonly known as Proposition 65."