

---

*Comfort-Cire*®

**Century**

---

**Design Guide**

**HKV Series**

## Table of Contents

**HKV Large Belt Drive Se-**

	Unit Features	3
	Selection Procedure	4
	HKV Series Nomenclature	6
	Performance Data - AHRI/ASHRAE/ISO 13256-1	8
	Performance Data - Selection Notes	9
	Performance Data - HKV084	10
	Performance Data - HKV096	11
	Performance Data - HKV120	12
	Performance Data - HKV150	13
	Performance Data - HKV168	14
	Performance Data - HKV192	15
	Performance Data - HKV240	16
	Performance Data - HKV300	17
	HKV Performance Data Correction Tables	18
	Antifreeze Correction and Water Pressure Drop Adder for Option Tables	19
	ClimaDry® II Options, Benefits, and Applications	20
	ClimaDry® II Sequence of Operation	22
	Blower Performance Data - HKV084 - Standard Unit - No ClimaDry®	24
	Blower Performance Data - HKV096 - Standard Unit - No ClimaDry®	25
	Blower Performance Data - HKV120 - Standard Unit - No ClimaDry®	26
	Blower Performance Data - HKV150 - Standard Unit - No ClimaDry®	28
	Blower Performance Data - HKV168 - Standard Unit - No ClimaDry®	30
	Blower Performance Data - HKV192 - Standard Unit - No ClimaDry®	31
	Blower Performance Data - HKV240 - Standard Unit - No ClimaDry®	32
	Blower Performance Data - HKV300 - Standard Unit - No ClimaDry®	34
	Blower Performance Data - Units with ClimaDry®	36
	HKV Physical Data	37
	HKV084-150 Dimensional Data	38
	HKV168-300 Dimensional Data	39
	HKV Electrical Data - Standard	40
	HKV Electrical Data - Dual Point Power	41
	HKV Electrical Data Standard with Internal Pump or ClimaDry®	42
	HKV Electrical Data - Dual Point Power with Pump or ClimaDry®	43
	HKV Series Wiring Diagram Matrix	44
	Typical Wiring Diagram - Three Phase HKV084-150 with CXM Controller	45
	Typical Wiring Diagram - Three Phase HKV084-150 with DXM2	46
	Engineering Specifications	47
	Revision History	58

## THE HKV LARGE SERIES

The award winning HKV Large Series raises the bar for Water-Source Heat Pump efficiencies, features, and application flexibility. Not only does the HKV exceed ASHRAE 90.1 efficiencies, but it also uses EarthPure® HFC-410A zero ozone depletion refrigerant, making it an extremely environmentally-friendly option. HKV Series is eligible for additional LEED® (Leadership in Energy and Environmental Design) points because of the “green” technology design.

Available in sizes 7 tons (24.6 kW) through 25 tons (87.9 kW) with multiple cabinet configurations, the HKV Large Series offers a wide range of units for most any installation. The HKV Large Series has an extended range refrigerant circuit, capable of ground loop (geothermal) applications (may require optional extended range insulation), ground water (geothermal) applications, as well as water loop (boiler-tower) applications. Standard features are many. Microprocessor controls, galvanized steel cabinet, galvanized steel with epoxy powder coat painted drain pan and TXV refrigerant metering device are just some of the features of the flexible HKV Large Series.

Comfort-Aire/Century's exclusive double isolation compressor mounting system makes the HKV Large Series one of the quietest units on the market. Compressors are mounted on specially engineered sound-tested EPDM grommets to a heavy gauge mounting plate, which is further isolated from the cabinet base with rubber grommets for maximized vibration and sound attenuation. The easy access control box and large access panels make installing and maintaining the unit easier than other water-source heat pumps currently in production.

Options such as coated air coil, DDC controls, and dual point power allow customized design solutions. Optional blower motor/sheave drive packages expand the operating range and help overcome some of the challenges associated with ductwork for retrofit installations. A cupro-nickel water-coil and sound

absorbing UltraQuiet package are options that make a great unit even better.

The HKV Large Series Water-Source Heat Pumps are designed to meet the challenges of today's HVAC demands with one of the most innovative products available on the market.

iGate® technology is the next generation in intelligent control by using two-way communication to provide a gateway into the system. The iGate control system allows end-users and contractors to monitor the performance of the unit, custom tailor its operation, and diagnose any issues, right from the thermostat.

## UNIT FEATURES

Vertical sizes 084 (7 tons, 24.6 kW), 096 (8 tons), 120 (10 tons), 150 (12.5 tons), 168 (14 tons), 192 (16 tons), 240 (20 tons), 300 (25 tons, 87.9 kW)

Unit configuration can be ordered with, or converted to front or back return and top, front, or back discharge.

Field conversion uses all existing parts including panels and belts

Electrical box can be field converted to be on front or back of unit

Electric power can enter from any side of unit

Water and drain can be connected to either side

Dual refrigeration circuits (HKV168, 192, 240, 300)

Exceeds ASHRAE 90.1 efficiencies

TXV metering device

Extended range 20 to 120°F (-6.7 to 48.9°C operation)

Microprocessor controls standard (optional DXM2 or DDC controls)

LonWorks, BACnet, Modbus and Johnson N2

compatibility options for DDC controls

Unit Performance Sentinel performance monitoring system

Belt drive blowers with high efficiency motors and multiple pulley adjustment

1", 2", or 4" (25, 50, or 100 mm) Full Filter Frame with bottom access

## OPTIONS INCLUDE

Hot gas bypass

Dual point power

Coated air coil

Extended range insulation

Cupro-nickel water coil

Stainless steel drain pan

# Selection Procedure

## Reference Calculations

Heating	Cooling	
$LWT = EWT - \frac{HE}{GPM \times 500}$	$LWT = EWT + \frac{HR}{GPM \times 500}$	$LC = TC - SC$
$LAT = EAT + \frac{HC}{CFM \times 1.08}$	$LAT (DB) = EAT (DB) - \frac{SC}{CFM \times 1.08}$	$S/T = \frac{SC}{TC}$

## Legend and Glossary of Abbreviations

BTUH = BTU (British Thermal Unit) per hour	HWC = hot water generator (desuperheater) capacity, Mbtuh
CFM = airflow, cubic feet/minute	FPT = female pipe thread
COP = coefficient of performance = BTUH output/BTUH input	KW = total power unit input, kilowatts
DB = dry bulb temperature (°F)	LAT = leaving air temperature, °F
EAT = entering air temperature, Fahrenheit (dry bulb/wet bulb)	LC = latent cooling capacity, BTUH
EER = energy efficiency ratio = BTUH output/Watt input	LWT = leaving water temperature, °F
MPT = male pipe thread	MBTUH = 1000 BTU per hour
ESP = external static pressure (inches w.g.)	S/T = sensible to total cooling ratio
EWT = entering water temperature	SC = sensible cooling capacity, BTUH
GPM = water flow in U.S. gallons/minute	TC = total cooling capacity, BTUH
HE = total heat of extraction, BTUH	WB = wet bulb temperature (°F)
HC = air heating capacity, BTUH	WPD = waterside pressure drop (psi & ft. of hd.)
HR = total heat of rejection, BTUH	

## Conversion Table - to convert inch-pound (English) to S-I (Metric)

Air Flow	Water Flow	Ext Static Pressure	Water Pressure Drop
Airflow (L/s) = CFM x 0.472	Water Flow (L/s) = gpm x 0.0081	ESP (Pa) = ESP (in of wg) x 2.49	PD (kPa) = PD (ft of hd) x 2.31

- Step 1** Determine the actual heating and cooling loads at the desired dry bulb and wet bulb conditions.
- Step 2** Obtain the following design parameters: Entering water temperature, water flow rate in GPM, air flow in CFM, water flow pressure drop and design wet and dry bulb temperatures. Air flow CFM should be between 300 and 450 CFM per ton. Unit water pressure drop should be kept as close as possible to each other to make water balancing easier. Go to the appropriate tables and find the proper indicated water flow and water temperature.
- Step 3** Select a unit based on total and sensible cooling conditions. Select a unit which is closest to the actual cooling load.
- Step 4** Use data from performance tables at the design water flow and water temperature. Read the total and sensible cooling capacities (Note: interpolation is permissible, extrapolation is not).
- Step 5** Read the heating capacity. If it exceeds the design criteria it is acceptable. It is quite normal for Water-Source Heat Pumps to be selected on cooling capacity only since the heating output is usually greater than the cooling capacity.
- Step 6** Determine the correction factors associated with the variable factors of dry bulb and wet bulb (page 14).  
 Corrected Total Cooling =  
 tabulated total cooling x wet bulb correction.  
 Corrected Sensible Cooling =  
 tabulated sensible cooling x wet/dry bulb correction.
- Step 7** Determine the correction factor associated with antifreeze in system loop. If heating EWT is 50°F or below you may have to use antifreeze. Calculate leaving water temperature per performance data selection notes (page 18). If antifreeze is required, use correction table for correcting total and sensible capacities.
- Step 8** Compare the corrected capacities to the load requirements. Normally if the capacities are within 10% of the loads, the equipment is acceptable. It is better to undersize than oversize, as undersizing improves humidity control, reduces sound levels and extends the life of the equipment.
- Step 9** When completed, calculate water temperature rise and assess the selection. If the units selected are not within 10% of the load calculations, then review what effect changing the GPM, water temperature and/or air flow and air temperature would have on the corrected capacities. If the desired capacity cannot be achieved, select the next larger or smaller unit and repeat the procedure. Remember, when in doubt,

undersize slightly for best performance.

## Example Equipment Selection For Cooling

### Step 1 Load Determination:

Assume you have determined that the appropriate cooling load at the desired dry bulb 80°F and wet bulb 65°F conditions is as follows:

Total Cooling.....	78,500 BTUH
Sensible Cooling.....	63,800 BTUH
Entering Air Temp.....	80°F Dry Bulb / 65°F Wet Bulb

### Step 2 Design Conditions:

Similarly, you have also obtained the following design parameters:

Entering Water Temp (Cooling).....	90°F
Entering Water Temp (Heating).....	60°F
Water Flow (Based upon 12°F rise in temp.)....	15.8 GPM
Air Flow.....	2,460 CFM

### Step 3, 4 & 5 HP Selection:

After making your preliminary selection (TLV084), we enter the data from tables at design water flow and water temperature and read Total Cooling, Sens. Cooling and Heat of Rej. capacities:

Total Cooling.....	80,453 BTUH
Sensible Cooling.....	60,370 BTUH
Heat of Rejection.....	101,755 BTUH
Airflow .....	2,800 CFM

### Step 6, 7 & 8 Entering Air, Airflow and Antifreeze Corrections:

Next, we determine our correction factors.

$$\text{Airflow } 2460 \div 2800 = 88\% \quad \text{Antifreeze - None}$$

	Table	Ent Air	Air Flow	Corrected
Corrected Total Cooling =	80,453	x .975	x .982	x 1 = 77,029
Corrected Sens Cooling =	60,370	x 1.096	x .940	x 1 = 62,195
Corrected Heat of Rejection =	101,775	x .979	x .974	= 97,028

### Step 9 Water Temperature Rise Calculation & Assessment:

$$\text{Rise} = \text{Heat of Rejection} \div (\text{GPM} \times 500)$$

$$\text{Actual Temperature Rise } 97,028 \div 7,900 = 12.3^\circ\text{F}$$

When we compare the Corrected Total Cooling and Corrected Sensible Cooling figures with our load requirements stated in Step 1, we discover that our selection is within +/- 10% of our sensible load requirement. Furthermore, we see that our Corrected Total Cooling figure is slightly undersized as recommended, when compared to the actual indicated load.

Alternate Step 7: If your EWT for heating is 40°F then system requires antifreeze. If a solution of 15% Propylene Glycol is required, then:

# HKV Series Nomenclature

1 2
3
4 5 6
7
8
9
10
11
12
13 14

HK
V
084
A
3
C
1
A
C
BT

**MODEL TYPE**  
HK = HEAT CONTROLLER LARGE COMMERCIAL

**CONFIGURATION**  
V = VERTICAL (NON PAINTED)

**UNIT SIZE**  
084  
096  
120  
150  
168  
192  
240  
300

**REVISION LEVEL**  
A = CURRENT REVISION FOR HKV

**VOLTAGE**  
3 = 208-230/60/3  
4 = 460/60/3  
5 = 575/60/3

**CONTROLS**  
C = CXM  
D = DXM  
L = CXM w/ LON  
M = DXM w/ LON  
N = CXM w/ MPC  
P = DXM w/ MPC

A = CXM  
B = DXM  
E = CXM w/LON  
K = DXM w/LON  
R = CXM w/MPC  
S = DXM w/MPC

w/ Disconnect

**AIR FLOW OPTIONS**  
BF = BACK RETURN / FRONT SUPPLY  
BT = BACK RETURN / TOP SUPPLY  
FB = FRONT RETURN / BACK SUPPLY  
FT = FRONT RETURN / TOP SUPPLY  
YF = BACK RETURN / FRONT SUPPLY + SS DRAIN PAN  
YT = BACK RETURN / TOP SUPPLY + SS DRAIN PAN  
ZB = FRONT RETURN / BACK SUPPLY + SS DRAIN PAN  
ZT = FRONT RETURN / TOP SUPPLY + SS DRAIN PAN

**HEAT EXCHANGER  
MOTORIZED VALVE / PUMP OPTIONS**

OPTION	COPPER WATER COIL	CUPRONICKEL WATER COIL	NON COATED AIR COIL	COATED AIR COIL	MTRZD VALVE (WATER OUT)	INTERNAL PUMP (WATER IN)
A			NO	YES		
C	YES	NO	YES	NO	NO	
J			NO	YES		
N	NO	YES	YES	NO		
U			NO	YES		
T	YES	NO	YES	NO	YES	NO
W			NO	YES		
S	NO	YES	YES	NO		
G			NO	YES		
H	YES	NO	YES	NO	NO	YES
Y			NO	YES		
Z	NO	YES	YES	NO		

**BLOWER DRIVE PACKAGE**  
A = STANDARD RPM & STANDARD MOTOR  
B = LOW & RPM & STANDARD MOTOR  
C = HIGH RPM & STANDARD MOTOR  
D = STANDARD RPM & LARGE MOTOR (NOT AVAILABLE FOR 240)  
E = HIGH RPM & LARGE MOTOR

**CABINET INSULATION / FILTER FRAME**

OPTION	RANGE	ULTRA QUIET	1" FILTER FRAME	2" FILTER FRAME	4" FILTER FRAME
1			YES		NO
A	EXTENDED RANGE	NO	NO	YES	NO
B				NO	YES
C				YES	NO
D		YES	NO	YES	NO
E	STANDARD RANGE	NO	NO	YES	NO
F			YES	NO	YES
G			NO	YES	NO
H		YES	NO	YES	NO

HKV with ClimaDry® II Model Nomenclature

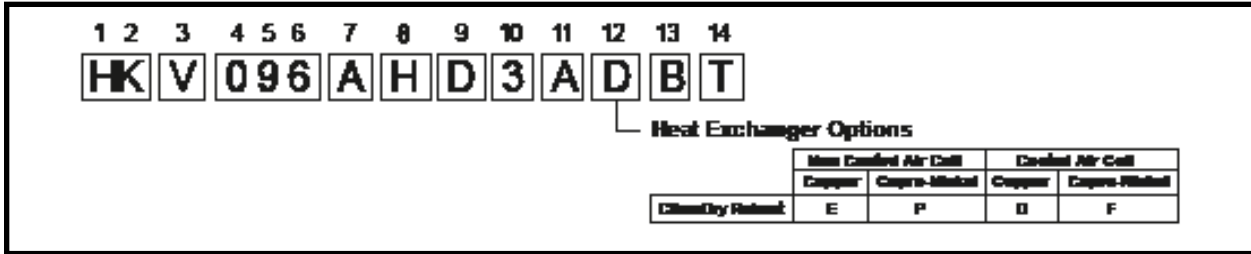

Notes:

1. ClimaDry® II reheat option (Digit 12 - D, E, F or P) must be ordered with original equipment (cannot be field added). Unit must have DXM2 control. Not available for units with internal water valve, flow regulator options, or 575 Volt. Check unit submittal for limitations and specific requirements.
2. Antifreeze is not required for TLV but may be required due to EWT in heating or other models with original ClimaDry® Option on the same loop.
3. ClimaDry® II is not recommended for applications with poor water quality (see water quality guidelines in unit IOM). The copper heat exchanger (Digit 12 - D or E) with cast iron pump are designed for closed loop systems.
4. The cupro-nickel heat exchanger (Digit 12 - F or P) also includes bronze pump, and is required for use with open loop or ground water systems.
5. Max working water pressure for the ClimaDry® II option is 145psig [999kPa].
6. Thermostat must be either:
  - A. Thermostat with dehumidification mode (ATP32U04 or similar)
  - B. Thermostat and separate humidistat or dehumidistat controller (see Page 22 for DXM2 DIP settings).
8. ClimaDry® II units must have minimum entering air temperature of 70°F DB / 61°F WB while in the cooling, continuous fan, or dehumidification modes. Minimum entering air temperature while operating in the heating mode (not continuous fan) is the minimum entering air temperature for the standard model (without the ClimaDry® option) in the heating mode. Operating below these minimum entering air temperatures may result in nuisance faults.

# Performance Data - AHRI/ASHRAE/ISO 13256-1

## ASHRAE/AHRI/ISO 13256-1. English (I-P) Units

Model	Water Loop Heat Pump				Ground Water Heat Pump				Ground Loop Heat Pump			
	Cooling 86°F		Heating 68°F		Cooling 59°F		Heating 50°F		Cooling 77°F		Heating 32°F	
	Capacity Btuh	EER Btuh/W	Capacity Btuh	COP	Capacity Btuh	EER Btuh/W	Capacity Btuh	COP	Capacity Btuh	EER Btuh/W	Capacity Btuh	COP
HKV084	82,000	15.2	101,000	4.8	87,500	21.0	83,500	4.3	83,000	16.5	65,500	3.6
HKV096	94,000	15.0	118,000	4.7	102,500	20.5	96,500	4.2	97,500	16.5	76,500	3.6
HKV120	118,000	15.0	144,000	5.0	133,000	21.0	118,000	4.2	120,000	16.5	93,000	3.7
HKV150	150,000	14.0	186,000	4.7	170,000	20.0	155,000	4.2	156,000	15.8	122,000	3.6
HKV168	166,000	15.5	204,020	4.9	177,000	21.4	169,000	4.4	168,000	16.8	132,500	3.7
HKV192	190,000	15.3	238,360	4.8	207,000	20.9	195,000	4.3	197,000	16.8	155,000	3.7
HKV240	238,500	15.3	291,000	5.1	269,000	21.4	238,500	4.3	242,500	16.8	188,000	3.8
HKV300	300,000	14.0	372,000	4.7	340,000	20.0	310,000	4.2	312,000	15.8	244,000	3.6

Cooling capacities based upon 80.6°F DB, 66.2°F WB entering air temperature.  
 Heating capacities based upon 68°F DB, 59°F WB entering air temperature.  
 All ratings based upon operation at lower voltage of dual voltage rated models  
 All HKV084 ratings at 2800 CFM with sheave settings at 3.5 turns open.  
 All HKV096 ratings at 3200 CFM with sheave settings at 3.0 turns open.  
 All HKV120 ratings at 4000 CFM with sheave settings at 2.5 turns open.

## ASHRAE/AHRI/ISO 13256-1. Metric (S-I) Units

Model	Water Loop Heat Pump				Ground Water Heat Pump				Ground Loop Heat Pump			
	Cooling 30°C		Heating 20°C		Cooling 15°C		Heating 10°C		Cooling 25°C		Heating 0°C	
	Capacity kW	EER W/W	Capacity kW	COP	Capacity kW	EER W/W	Capacity kW	COP	Capacity kW	EER W/W	Capacity kW	COP
HKV084	24.03	4.5	29.60	4.8	25.65	6.2	24.47	4.3	24.33	4.8	19.20	3.6
HKV096	27.55	4.4	34.58	4.7	30.04	6.0	28.28	4.2	28.58	4.8	22.42	3.6
HKV120	34.58	4.4	42.20	5.0	38.98	6.2	34.58	4.2	35.17	4.8	27.26	3.7
HKV150	43.96	4.1	54.51	4.7	49.82	5.9	45.43	4.2	45.72	4.6	35.76	3.6
HKV168	48.65	4.5	59.80	4.9	51.87	6.3	49.53	4.4	49.24	4.9	38.83	3.7
HKV192	55.69	4.5	69.86	4.8	60.67	6.1	57.15	4.3	57.74	4.9	45.43	3.7
HKV240	69.90	4.5	85.29	5.1	78.84	6.3	69.90	4.3	71.07	4.9	55.10	3.8
HKV300	87.93	4.1	109.03	4.7	99.65	5.9	90.86	4.2	91.44	4.6	71.51	3.6

Cooling capacities based upon 27°C DB, 19°C WB entering air temperature.  
 Heating capacities based upon 20°C DB, 15°C WB entering air temperature.  
 All ratings based upon operation at lower voltage of dual voltage rated models.  
 All HKV084 ratings at 1321 l/s with sheave settings at 3.5 turns open.  
 All HKV096 ratings at 1510 l/s with sheave settings at 3.5 turns open.  
 All HKV120 ratings at 1888 l/s with sheave settings at 3.5 turns open.

## Performance Data - Selection Notes

For operation in the shaded area when water is used in lieu of an antifreeze solution, the LWT (Leaving Water Temperature) must be calculated. Flow must be maintained to a level such that the LWT is maintained above 42°F [5.6°C] when the JW3 jumper is not clipped (see example below). Otherwise, appropriate levels of a proper antifreeze solution should be used in systems with leaving water temperatures of 42°F [5.6°C] or below and the JW3 jumper should be clipped. This is due to the potential of the refrigerant temperature being as low as 32°F [0°C] with 40°F [4.4°C] LWT, which may lead to a nuisance cutout due to the activation of the Low Temperature Protection. JW3 should never be clipped for standard range equipment or systems without antifreeze.

### Example:

At 50°F EWT (Entering Water Temperature) and 1.5 gpm/ton, a 3 ton unit has a HE of 22,500 Btuh. To calculate LWT, rearrange the formula for HE as follows:

$HE = TD \times GPM \times 500$ , where HE = Heat of Extraction (Btuh); TD = temperature difference (EWT - LWT) and GPM = U.S. Gallons per Minute.

$$TD = HE / (GPM \times 500)$$

$$TD = 22,500 / (1.5 \times 500)$$

$$TD = 10^\circ\text{F}$$

$$LWT = EWT - TD$$

$$LWT = 50 - 10 = 40^\circ\text{F}$$

In this example, a higher flow rate will be required for EWTs at or below 50°F without antifreeze. At 2 gpm/ton, the calculation above results in a TD of 7.5.  $LWT = 50 - 7.5 = 42.5^\circ\text{F}$ , which is above 42°F EWT, and is acceptable for this application.

		Heating - EAT 70°F				
	EER	HC	kW	HE	LAT	COP
50.0	21.8	42.7	4.00	29.1	86.5	3.13
49.6	21.8	47.7	4.19	33.4	88.4	3.33
49.5	23.6	49.9	4.28	35.3	89.2	3.41
49.4	24.4	51.1	4.33	36.3	89.7	3.46
49.8	19.4	55.5	4.50	40.1	91.4	3.61
49.3	21.1	58.2	4.60	42.5	92.4	3.70
49.4	21.9	59.6	4.66	43.7	93.0	3.75
49.1	17.1	63.4	4.80	47.0	94.4	3.87
48.7	18.7	66.6	4.91	49.8	95.7	3.97
48.5	19.5	68.3	4.98	51.3	96.3	4.02
48.3	20.3	70.0	5.09	54.0	97.5	4.11

# Performance Data - HKV084

## 2800 CFM Nominal Airflow Heating & Cooling

Performance capacities shown in thousands of Btuh

WATER/BRINE				Cooling - EAT 80/67°F					Heating - EAT 70°F				
EWT °F	FLOW gpm	PD psi	PD ft.	TC	SC	kW	HR	EER	HC	kW	HE	LAT	COP
20	21.00	10.0	23.1	Operation not recommended					58.0	5.3	39.7	86.7	3.2
30	10.50	2.4	5.5	81.7	57.1	3.8	94.7	21.4	63.2	5.5	44.5	89.9	3.4
	15.75	5.5	12.6	77.1	53.5	3.5	89.1	22.0	65.8	5.6	46.9	90.8	3.5
	21.00	9.2	21.3	74.5	51.5	3.4	86.0	22.1	67.3	5.6	48.2	91.2	3.5
40	10.50	2.1	4.9	86.4	61.0	4.3	101.1	20.2	72.6	5.7	53.0	93.2	3.7
	15.75	5.0	11.4	84.0	58.8	4.0	97.6	21.0	76.0	5.8	56.1	94.3	3.8
	21.00	8.4	19.5	82.3	57.5	3.9	95.5	21.3	77.9	5.9	57.9	95.0	3.9
50	10.50	2.0	4.5	88.0	62.8	4.7	104.1	18.7	82.7	6.0	62.2	96.4	4.0
	15.75	4.6	10.7	87.3	61.8	4.4	102.4	19.7	87.0	6.1	66.1	97.8	4.2
	21.00	7.9	18.4	86.5	61.1	4.3	101.2	20.1	89.4	6.2	68.3	98.6	4.2
60	10.50	1.3	3.1	87.0	62.8	5.1	104.5	17.0	93.3	6.3	71.8	100.2	4.3
	15.75	3.6	8.3	87.6	62.7	4.8	104.1	18.1	98.2	6.4	76.3	101.8	4.5
	21.00	6.5	14.9	87.6	62.4	4.7	103.7	18.6	100.9	6.5	78.8	102.7	4.6
70	10.50	1.2	2.8	84.8	62.2	5.6	103.8	15.2	103.7	6.6	81.3	103.9	4.6
	15.75	3.4	7.8	86.4	62.7	5.3	104.4	16.4	109.2	6.7	86.2	105.7	4.8
	21.00	6.2	14.2	87.0	62.8	5.1	104.5	17.0	112.1	6.8	88.9	106.7	4.8
80	10.50	1.1	2.6	81.9	61.0	6.1	102.6	13.5	113.8	6.9	90.4	107.2	4.9
	15.75	3.1	7.3	84.2	61.9	5.7	103.7	14.7	119.4	7.0	95.5	109.1	5.0
	21.00	5.8	13.5	85.2	62.3	5.6	104.2	15.3	122.2	7.1	98.0	110.0	5.0
85	10.50	1.1	2.5	79.9	60.1	6.3	101.5	12.7	118.4	7.0	94.6	108.7	5.0
	15.75	3.1	7.2	82.3	61.1	6.0	102.8	13.8	123.8	7.2	99.4	110.5	5.1
	21.00	5.7	13.3	83.4	61.5	5.8	103.3	14.4	126.5	7.2	101.8	111.4	5.1
90	10.50	1.1	2.4	77.8	59.3	6.6	100.3	11.8	123.0	7.1	98.7	110.3	5.1
	15.75	3.0	7.0	80.5	60.4	6.2	101.8	12.9	128.2	7.3	103.3	112.0	5.2
	21.00	5.7	13.1	81.7	60.9	6.1	102.4	13.5	130.7	7.4	105.5	112.8	5.2
100	10.50	1.0	2.3	73.5	57.5	7.2	98.2	10.2	Operation not recommended				
	15.75	2.9	6.8	76.2	58.6	6.8	99.5	11.2					
	21.00	5.5	12.8	77.6	59.2	6.6	100.2	11.7					
110	10.50	0.9	2.1	69.2	55.8	8.0	96.4	8.7	Operation not recommended				
	15.75	2.8	6.5	71.8	56.8	7.5	97.4	9.6					
	21.00	5.4	12.4	73.2	57.4	7.3	98.0	10.1					
120	10.50	0.9	2.0	65.3	54.6	8.8	95.5	7.4	Operation not recommended				
	15.75	2.7	6.3	67.6	55.3	8.3	95.9	8.1					
	21.00	5.2	12.1	68.8	55.7	8.0	96.3	8.6					

Interpolation is permissible; extrapolation is not.  
 All entering air conditions are 80°F DB and 67°F WB in cooling, and 70°F DB in heating.  
 AHRI/ISO certified conditions are 80.6°F DB and 66.2°F WB in cooling and 68°F DB in heating.  
 Table does not reflect fan or pump power corrections for AHRI/ISO conditions.  
 All performance is based upon the lower voltage of dual voltage rated units.  
 Performance stated is at the rated power supply; performance may vary as the power supply varies from the rated.  
 Operation below 40°F EWT is based upon a 15% methanol antifreeze solution.  
 Operation below 60°F EWT requires optional insulated water/refrigerant circuit.  
 See performance correction tables for operating conditions other than those listed above.  
 See Performance Data Selection Notes for operation in the shaded areas.  
 For additional pressure drop of unit options, see table on page 19.

# Performance Data - HKV096

## 3200 CFM Nominal Airflow Heating & Cooling

Performance capacities shown in thousands of Btuh

WATER/BRINE				Cooling - EAT 80/67°F					Heating - EAT 70°F				
EWT °F	FLOW gpm	PD psi	PD ft.	TC	SC	kW	HR	EER	HC	kW	HE	LAT	COP
20	24.0	14.1	32.6	Operation not recommended					64.6	6.2	43.3	88.3	3.0
30	12.0	3.8	8.7	89.1	62.2	3.9	102.5	22.8	71.0	6.4	49.2	90.2	3.3
	18.0	8.0	18.6	79.1	54.9	3.2	90.0	24.7	74.1	6.5	52.0	91.1	3.4
	24.0	13.0	29.9	73.7	51.1	2.9	83.5	25.8	75.8	6.5	53.5	91.5	3.4
40	12.0	3.4	7.8	99.8	69.8	4.9	116.4	20.5	82.0	6.7	59.1	93.3	3.6
	18.0	7.2	16.7	94.6	66.1	4.3	109.4	21.8	85.9	6.8	62.7	94.5	3.7
	24.0	11.8	27.2	91.2	63.6	4.1	105.1	22.5	88.1	6.9	64.7	95.1	3.8
50	12.0	3.1	7.2	103.1	72.3	5.5	121.8	18.8	93.7	7.0	69.6	96.7	3.9
	18.0	6.8	15.6	101.6	71.1	5.1	119.0	19.9	98.5	7.2	74.0	98.1	4.0
	24.0	11.2	25.9	100.1	70.0	4.9	116.8	20.5	101.1	7.2	76.5	98.8	4.1
60	12.0	2.4	5.6	102.2	72.0	6.0	122.6	17.1	105.9	7.4	80.6	100.4	4.2
	18.0	5.6	12.9	103.2	72.5	5.7	122.5	18.3	111.6	7.5	85.8	102.0	4.3
	24.0	9.6	22.2	103.2	72.3	5.5	121.9	18.8	114.7	7.6	88.7	103.0	4.4
70	12.0	2.3	5.2	98.7	70.1	6.4	120.6	15.4	118.2	7.7	91.8	104.1	4.5
	18.0	5.3	12.2	101.2	71.5	6.1	122.1	16.6	124.7	7.9	97.7	106.0	4.6
	24.0	9.2	21.2	102.2	72.0	6.0	122.5	17.1	128.3	8.0	100.9	107.0	4.7
80	12.0	2.1	4.8	93.7	67.6	6.9	117.1	13.6	130.4	8.1	102.8	107.6	4.7
	18.0	5.0	11.5	97.0	69.3	6.6	119.4	14.8	137.5	8.3	109.2	109.7	4.9
	24.0	8.7	20.2	98.5	70.1	6.4	120.4	15.4	141.3	8.4	112.7	110.8	4.9
85	12.0	2.1	4.8	90.9	66.3	7.1	115.3	12.8	136.3	8.3	108.1	109.4	4.8
	18.0	4.9	11.3	94.3	67.9	6.8	117.5	13.9	143.6	8.5	114.7	111.5	5.0
	24.0	8.6	20.0	95.9	68.8	6.6	118.6	14.5	147.5	8.6	118.2	112.7	5.0
90	12.0	2.0	4.7	88.1	65.0	7.4	113.5	11.9	142.2	8.4	113.5	111.1	4.9
	18.0	4.8	11.2	91.5	66.6	7.1	115.6	13.0	149.8	8.7	120.2	113.3	5.1
	24.0	8.6	19.8	93.3	67.5	6.9	116.8	13.6	153.8	8.8	123.7	114.5	5.1
100	12.0	1.9	4.5	83.2	63.2	8.1	110.9	10.2	Operation not recommended				
	18.0	4.7	10.9	86.2	64.2	7.7	112.4	11.2					
	24.0	8.4	19.4	87.9	64.9	7.5	113.3	11.8					
110	12.0	1.9	4.3	79.5	62.7	9.1	110.5	8.8					
	18.0	4.6	10.5	81.6	62.8	8.5	110.5	9.6					
	24.0	8.2	18.9	82.9	63.1	8.2	110.9	10.1					
120	12.0	1.8	4.1	78.3	65.0	10.4	113.8	7.5					
	18.0	4.4	10.2	78.7	63.2	9.5	111.2	8.3					
	24.0	8.0	18.5	79.3	62.8	9.2	110.6	8.7					

Interpolation is permissible; extrapolation is not.  
 All entering air conditions are 80°F DB and 67°F WB in cooling, and 70°F DB in heating.  
 AHRI/ISO certified conditions are 80.6°F DB and 66.2°F WB in cooling and 68°F DB in heating.  
 Table does not reflect fan or pump power corrections for AHRI/ISO conditions.  
 All performance is based upon the lower voltage of dual voltage rated units.  
 Performance stated is at the rated power supply; performance may vary as the power supply varies from the rated.  
 Operation below 40°F EWT is based upon a 15% methanol antifreeze solution.  
 Operation below 60°F EWT requires optional insulated water/refrigerant circuit.  
 See performance correction tables for operating conditions other than those listed above.  
 See Performance Data Selection Notes for operation in the shaded areas.  
 For additional pressure drop of unit options, see table on page 19.

# Performance Data - HKV120

## 4000 CFM Nominal Airflow Heating & Cooling

Performance capacities shown in thousands of Btu/h

WATER/BRINE				Cooling - EAT 80/67°F					Heating - EAT 70°F				
EWT °F	FLOW gpm	PD psi	PD ft.	TC	SC	kW	HR	EER	HC	kW	HE	LAT	COP
20	30.00	10.2	23.5	Operation not recommended					82.040	7.73	55.660	88.6	3.1
30	15.00	2.1	4.8	142.3	97.1	6.3	163.6	22.8	88.8	7.9	61.9	90.2	3.3
	22.50	5.3	12.2	144.2	97.0	6.0	164.7	24.1	92.1	7.9	65.0	90.9	3.4
	30.00	9.4	21.6	144.9	96.7	5.9	164.9	24.7	93.9	8.0	66.7	91.4	3.4
40	15.00	1.9	4.3	138.6	96.0	6.6	161.3	20.8	100.9	8.1	73.1	93.0	3.6
	22.50	4.8	11.1	141.5	96.9	6.3	163.2	22.3	105.4	8.2	77.3	94.0	3.7
	30.00	8.6	19.8	142.7	97.1	6.2	163.9	23.0	107.8	8.3	79.5	94.6	3.8
50	15.00	1.7	4.0	133.9	94.0	7.1	158.1	18.8	114.4	8.5	85.6	96.0	4.0
	22.50	4.4	10.1	137.5	95.6	6.8	160.6	20.3	120.0	8.6	90.8	97.3	4.1
	30.00	8.1	18.8	139.1	96.2	6.6	161.7	21.0	123.1	8.6	93.7	98.1	4.2
60	15.00	1.3	3.0	128.4	91.4	7.6	154.4	16.8	129.7	8.8	99.7	99.6	4.3
	22.50	3.7	8.6	132.4	93.3	7.3	157.1	18.2	136.4	8.9	106.0	101.1	4.5
	30.00	7.0	16.2	134.3	94.2	7.1	158.5	19.0	140.2	9.0	109.5	102.0	4.6
70	15.00	1.2	2.7	122.1	88.2	8.2	150.2	14.8	145.5	9.1	114.4	103.2	4.7
	22.50	3.5	8.1	126.4	90.3	7.8	153.1	16.2	153.4	9.3	121.7	105.0	4.8
	30.00	6.7	15.4	128.5	91.3	7.6	154.5	16.9	157.7	9.4	125.7	106.0	4.9
80	15.00	1.1	2.4	115.4	85.0	9.0	145.9	12.9	160.5	9.4	128.2	106.6	5.0
	22.50	3.3	7.6	119.6	87.0	8.5	148.5	14.1	169.1	9.6	136.2	108.6	5.1
	30.00	6.4	14.7	121.8	88.1	8.2	149.9	14.8	173.8	9.8	140.5	109.7	5.2
85	15.00	1.1	2.4	111.9	83.5	9.4	143.8	12.0	169.9	9.7	136.8	109.0	5.1
	22.50	3.2	7.4	116.2	85.5	8.9	146.4	13.2	174.6	9.5	142.0	110.6	5.4
	30.00	6.3	14.4	118.3	86.5	8.6	147.7	13.8	177.2	9.5	144.8	111.4	5.5
90	15.00	1.0	2.3	108.5	81.9	9.8	141.7	11.1	179.4	10.0	145.3	111.4	5.3
	22.50	3.2	7.4	112.7	83.9	9.2	144.2	12.2	180.0	9.4	147.8	112.5	5.6
	30.00	6.2	14.3	114.9	84.9	9.0	145.5	12.8	180.5	9.2	149.1	113.1	5.8
100	15.00	0.9	2.2	102.1	79.3	10.7	138.5	9.6	Operation not recommended				
	22.50	3.1	7.2	106.1	80.9	10.1	140.5	10.5					
	30.00	6.0	13.9	108.2	81.8	9.8	141.6	11.0					
110	15.00	0.9	2.0	96.1	77.2	11.7	136.1	8.2					
	22.50	3.0	6.9	99.7	78.4	11.1	137.5	9.0					
	30.00	5.8	13.4	101.7	79.1	10.8	138.4	9.5					
120	15.00	0.8	1.9	90.6	76.0	12.9	134.7	7.0					
	22.50	2.9	6.7	93.8	76.6	12.2	135.4	7.7					
	30.00	5.6	13.0	95.5	77.0	11.8	135.9	8.1					

Interpolation is permissible; extrapolation is not.  
 All entering air conditions are 80°F DB and 67°F WB in cooling, and 70°F DB in heating.  
 AHR/ISO certified conditions are 80.6°F DB and 66.2°F WB in cooling and 68°F DB in heating.  
 Table does not reflect fan or pump power corrections for AHR/ISO conditions.  
 All performance is based upon the lower voltage of dual voltage rated units.  
 Performance stated is at the rated power supply; performance may vary as the power supply varies from the rated.  
 Operation below 40°F EWT is based upon a 15% methanol antifreeze solution.  
 Operation below 60°F EWT requires optional insulated water/refrigerant circuit.  
 See performance correction tables for operating conditions other than those listed above.  
 See Performance Data Selection Notes for operation in the shaded areas.  
 For additional pressure drop of unit options, see table on page 19.

# Performance Data - HKV150

## 5000 CFM Nominal Airflow Heating & Cooling

Performance capacities shown in thousands of Btu/h

WATER/BRINE				Cooling - EAT 80/67°F					Heating - EAT 70°F				
EWT °F	FLOW gpm	PD psi	PD ft.	TC	SC	kW	HR	EER	HC	kW	HE	LAT	COP
20	38.0	12.0	27.6	Operation not recommended					105.5	10.3	70.5	89.0	3.0
30	19.0	2.7	6.3	175.0	131.8	8.3	203.4	21.0	115.1	10.5	79.1	90.7	3.2
	28.0	6.2	14.3	173.8	138.0	7.9	200.8	21.9	119.5	10.7	83.1	91.5	3.3
	38.0	11.0	25.4	172.3	141.6	7.7	198.6	22.4	122.2	10.7	85.5	92.0	3.3
40	19.0	2.3	5.4	173.5	123.9	8.9	204.0	19.4	131.5	11.0	94.0	93.7	3.5
	28.0	5.6	12.8	174.8	129.0	8.5	203.9	20.6	137.2	11.1	99.2	94.8	3.6
	38.0	10.0	23.2	174.9	132.2	8.3	203.1	21.1	140.7	11.2	102.5	95.4	3.7
50	19.0	2.1	4.9	169.2	117.6	9.5	201.8	17.8	149.0	11.4	110.1	96.9	3.8
	28.0	5.2	12.0	172.4	121.6	9.1	203.4	19.0	156.0	11.5	116.6	98.2	4.0
	38.0	9.5	21.9	173.6	124.2	8.9	203.9	19.6	160.3	11.6	120.6	99.0	4.0
60	19.0	1.7	3.8	163.0	112.7	10.2	197.7	16.0	167.9	11.8	127.5	100.5	4.2
	28.0	4.3	9.9	167.3	115.8	9.7	200.5	17.2	176.1	12.0	135.1	102.0	4.3
	38.0	8.0	18.5	169.5	117.8	9.5	201.8	17.9	181.1	12.1	139.7	103.0	4.4
70	19.0	1.5	3.5	155.5	108.5	11.0	192.9	14.2	187.1	12.3	145.1	104.2	4.5
	28.0	4.1	9.4	160.6	111.0	10.4	196.2	15.4	196.3	12.5	153.6	105.9	4.6
	38.0	7.7	17.8	163.3	112.6	10.2	198.0	16.1	201.9	12.7	158.7	106.9	4.7
80	19.0	1.4	3.2	147.2	104.9	11.8	187.6	12.4	205.2	12.7	161.7	107.5	4.7
	28.0	3.8	8.8	152.6	107.1	11.3	191.0	13.5	215.0	13.0	170.6	109.4	4.8
	38.0	7.4	17.0	155.6	108.4	11.0	193.0	14.2	220.8	13.2	175.8	110.4	4.9
85	19.0	1.4	3.1	142.9	103.2	12.4	185.0	11.6	213.8	13.0	169.5	109.1	4.8
	28.0	3.8	8.7	148.2	105.3	11.8	188.3	12.7	223.7	13.3	178.3	111.0	4.9
	38.0	7.3	16.7	151.3	106.5	11.4	190.2	13.3	229.3	13.5	183.3	112.0	5.0
90	19.0	1.3	3.0	138.6	101.6	12.9	182.4	10.8	222.4	13.2	177.3	110.7	4.9
	28.0	3.7	8.5	143.9	103.5	12.2	185.6	11.8	232.3	13.6	186.0	112.5	5.0
	38.0	7.2	16.6	146.9	104.7	11.9	187.5	12.4	237.9	13.8	190.9	113.6	5.1
100	19.0	1.2	2.9	130.3	98.4	14.0	178.1	9.3	Operation not recommended				
	28.0	3.6	8.2	135.2	100.3	13.3	180.6	10.2					
	38.0	7.0	16.1	138.1	101.4	12.9	182.2	10.7					
110	19.0	1.2	2.7	123.0	95.5	15.4	175.4	8.0					
	28.0	3.4	7.9	127.2	97.2	14.5	176.8	8.7					
	38.0	6.8	15.6	129.8	98.2	14.1	177.9	9.2					
120	19.0	1.1	2.5	117.3	93.0	17.0	175.2	6.9					
	28.0	3.3	7.7	120.4	94.4	16.0	175.0	7.5					
	38.0	6.5	15.1	122.4	95.3	15.5	175.3	7.9					

Interpolation is permissible; extrapolation is not.  
 All entering air conditions are 80°F DB and 67°F WB in cooling, and 70°F DB in heating.  
 AHRI/ISO certified conditions are 80.6°F DB and 66.2°F WB in cooling and 68°F DB in heating.  
 Table does not reflect fan or pump power corrections for AHRI/ISO conditions.  
 All performance is based upon the lower voltage of dual voltage rated units.  
 Performance stated is at the rated power supply; performance may vary as the power supply varies from the rated.  
 Operation below 40°F EWT is based upon a 15% methanol antifreeze solution.  
 Operation below 60°F EWT requires optional insulated water/refrigerant circuit.  
 See performance correction tables for operating conditions other than those listed above.  
 See Performance Data Selection Notes for operation in the shaded areas.  
 For additional pressure drop of unit options, see table on page 19.

# Performance Data - HKV168

## 5600 CFM Nominal (Rated) Airflow

Performance capacities shown in thousands of Btu/h

WATER/BRINE				Cooling - EAT 80/67°F					Heating - EAT 70°F				
EWT °F	FLOW gpm	PD psi	PD ft.	TC	SC	kW	HR	EER	HC	kW	HE	LAT	COP
<b>20</b>	42.0	11.3	26.0	Operation not recommended					116.0	10.7	79.5	86.7	3.2
<b>30</b>	21.0	2.7	6.2	163.5	114.1	7.6	189.5	21.3	126.5	11.0	89.1	88.4	3.4
	31.5	6.1	14.2	154.3	107.0	7.0	178.2	21.9	131.7	11.1	93.7	89.2	3.4
	42.0	10.4	24.0	149.0	103.1	6.7	172.0	22.0	134.5	11.2	96.4	89.6	3.5
<b>40</b>	21.0	2.4	5.5	172.9	122.0	8.6	202.1	20.1	145.2	11.5	106.0	91.3	3.7
	31.5	5.6	12.9	167.9	117.7	8.0	195.2	20.9	152.0	11.7	112.3	92.4	3.8
	42.0	9.5	21.9	164.6	115.0	7.7	191.0	21.2	155.9	11.8	115.8	93.1	3.9
<b>50</b>	21.0	2.2	5.1	176.0	125.6	9.4	208.1	18.6	165.5	12.0	124.5	94.6	4.0
	31.5	5.2	12.0	174.5	123.6	8.9	204.8	19.6	174.0	12.2	132.3	96.0	4.1
	42.0	8.9	20.6	173.0	122.1	8.6	202.4	20.0	178.7	12.4	136.6	96.7	4.2
<b>60</b>	21.0	1.5	3.5	173.9	125.5	10.3	208.9	16.9	186.5	12.6	143.6	98.0	4.3
	31.5	4.0	9.3	175.2	125.3	9.7	208.3	18.0	196.5	12.8	152.7	99.6	4.5
	42.0	7.3	16.8	175.2	124.8	9.4	207.4	18.6	201.9	13.0	157.6	100.4	4.5
<b>70</b>	21.0	1.4	3.2	169.6	124.3	11.2	207.6	15.2	207.5	13.2	162.6	101.3	4.6
	31.5	3.8	8.7	172.8	125.3	10.6	208.8	16.3	218.4	13.5	172.5	103.1	4.8
	42.0	6.9	16.0	174.0	125.6	10.3	209.0	16.9	224.2	13.6	177.7	104.0	4.8
<b>80</b>	21.0	1.3	2.9	163.8	122.0	12.1	205.1	13.4	227.6	13.7	180.9	104.6	4.9
	31.5	3.5	8.2	168.3	123.8	11.5	207.5	14.6	238.8	14.0	190.9	106.4	5.0
	42.0	6.6	15.2	170.4	124.6	11.2	208.5	15.2	244.6	14.2	196.0	107.3	5.0
<b>85</b>	21.0	1.3	2.8	159.7	120.2	12.7	202.9	12.6	236.8	14.0	189.1	106.1	5.0
	31.5	3.5	8.0	164.6	122.3	12.0	205.5	13.7	247.6	14.3	198.8	107.8	5.1
	42.0	6.5	15.0	166.9	123.2	11.7	206.7	14.3	252.9	14.5	203.5	108.64	5.1
<b>90</b>	21.0	1.2	2.7	155.6	118.5	13.2	200.7	11.7	246.0	14.3	197.4	107.5	5.1
	31.5	3.4	7.9	160.9	120.7	12.5	203.5	12.8	256.4	14.6	206.7	109.2	5.1
	42.0	6.4	14.8	163.4	121.8	12.1	204.9	13.4	261.4	14.8	211.1	110.0	5.2
<b>100</b>	21.0	1.1	2.6	147.0	114.9	14.5	196.3	10.1	Operation not recommended				
	31.5	3.3	7.6	152.5	117.2	13.7	199.1	11.1					
	42.0	6.2	14.4	155.2	118.3	13.3	200.5	11.6					
<b>110</b>	21.0	1.0	2.4	138.4	111.6	15.9	192.8	8.6					
	31.5	3.2	7.3	143.7	113.6	15.0	194.9	9.5					
	42.0	6.1	14.0	146.4	114.7	14.6	196.1	10.0					
<b>120</b>	21.0	1.0	2.2	130.6	109.2	17.7	191.0	7.3					
	31.5	3.0	7.0	135.2	110.5	16.6	191.8	8.1					
	42.0	5.9	13.6	137.7	111.4	16.1	192.6	8.5					

Interpolation is permissible; extrapolation is not.  
 All entering air conditions are 80°F DB and 67°F WB in cooling, and 70°F DB in heating.  
 AHRI/ISO certified conditions are 80.6°F DB and 66.2°F WB in cooling and 68°F DB in heating.  
 Table does not reflect fan or pump power corrections for AHRI/ISO conditions.  
 All performance is based upon the lower voltage of dual voltage rated units.  
 Performance stated is at the rated power supply; performance may vary as the power supply varies from the rated.  
 Operation below 40°F EWT is based upon a 15% methanol antifreeze solution.  
 Operation below 60°F EWT requires optional insulated water/refrigerant circuit.  
 See performance correction tables for operating conditions other than those listed above.  
 See Performance Data Selection Notes for operation in the shaded areas.  
 For additional pressure drop of unit options, see table on page 19.

6400 CFM Nominal Airflow Heating & Cooling

Performance capacities shown in thousands of Btu/h

WATER/BRINE				Cooling - EAT 80/67°F					Heating - EAT 70°F				
EWT °F	FLOW gpm	PD psi	PD ft.	TC	SC	kW	HR	EER	HC	kW	HE	LAT	COP
20	48.0	15.9	36.7	Operation not recommended					129.2	12.5	86.6	86.4	3.0
	24.0	4.2	9.8	178.3	124.3	7.8	205.0	22.8	142.1	12.8	98.5	88.3	3.2
	36.0	9.0	20.9	158.1	109.8	6.4	180.0	24.7	148.2	13.0	104.0	89.1	3.3
30	48.0	14.6	33.7	147.4	102.1	5.7	166.9	25.8	151.5	13.0	107.0	89.6	3.4
	24.0	3.8	8.7	199.6	139.6	9.7	232.7	20.5	164.0	13.4	118.3	91.4	3.6
	36.0	8.1	18.8	189.3	132.1	8.7	218.9	21.8	171.9	13.6	125.4	92.5	3.7
40	48.0	13.3	30.6	182.5	127.2	8.1	210.2	22.5	176.2	13.7	129.3	93.1	3.7
	24.0	3.5	8.1	206.1	144.7	11.0	243.6	18.7	187.3	14.1	139.3	94.7	3.9
	36.0	7.6	17.6	203.2	142.3	10.2	238.0	19.9	196.9	14.3	148.1	96.1	4.0
50	48.0	12.6	29.1	200.2	140.0	9.8	233.5	20.4	202.3	14.5	152.9	96.8	4.1
	24.0	2.7	6.3	204.4	144.1	11.9	245.1	17.0	211.7	14.8	161.3	98.1	4.2
	36.0	6.3	14.5	206.5	144.9	11.3	245.0	18.2	223.1	15.1	171.7	99.7	4.4
60	48.0	10.8	24.9	206.4	144.7	11.0	243.8	18.7	229.4	15.2	177.4	100.6	4.4
	24.0	2.6	5.9	197.4	140.3	12.8	241.1	15.3	236.5	15.5	183.6	101.6	4.5
	36.0	6.0	13.8	202.5	143.0	12.2	244.2	16.4	249.5	15.8	195.4	103.4	4.6
70	48.0	10.3	23.8	204.4	143.9	11.9	245.1	17.0	256.6	16.0	201.8	104.4	4.7
	24.0	2.4	5.5	187.4	135.1	13.7	234.3	13.6	260.7	16.2	205.6	105.0	4.8
	36.0	5.6	13.0	194.0	138.5	13.1	238.7	14.7	275.0	16.6	218.4	107.0	4.9
80	48.0	9.8	22.7	197.0	140.1	12.8	240.8	15.3	282.7	16.8	225.3	108.1	5.0
	24.0	2.4	5.4	181.8	132.6	14.3	230.6	12.7	272.6	16.5	216.2	106.7	4.9
	36.0	5.6	12.8	188.5	135.9	13.6	235.0	13.8	287.2	17.0	229.4	108.8	5.0
85	48.0	9.7	22.4	191.8	137.5	13.3	237.2	14.4	295.1	17.2	236.4	109.9	5.1
	24.0	2.3	5.3	176.3	130.1	14.8	226.9	11.8	284.4	16.9	226.9	108.4	5.0
	36.0	5.5	12.6	183.1	133.3	14.1	231.2	12.9	299.5	17.3	240.3	110.5	5.1
90	48.0	9.6	22.3	186.6	135.0	13.8	233.5	13.5	307.5	17.6	247.4	111.6	5.2
	24.0	2.2	5.1	166.4	126.3	16.3	221.9	10.2	Operation not recommended				
	36.0	5.3	12.2	172.4	128.5	15.3	224.8	11.2					
48.0	9.4	21.8	175.8	129.9	14.9	226.7	11.7						
100	24.0	2.1	4.9	159.0	125.4	18.1	220.9	8.7	Operation not recommended				
	36.0	5.1	11.9	163.2	125.6	16.9	220.9	9.6					
	48.0	9.2	21.3	165.8	126.2	16.4	221.7	10.1					
110	24.0	2.0	4.7	156.6	130.1	20.8	227.6	7.5	Operation not recommended				
	36.0	5.0	11.5	157.4	126.4	19.1	222.4	8.2					
	48.0	9.0	20.8	158.7	125.6	18.3	221.3	8.6					
120	Operation not recommended												

Interpolation is permissible; extrapolation is not.  
 All entering air conditions are 80°F DB and 67°F WB in cooling, and 70°F DB in heating.  
 AHR/ISO certified conditions are 80.6°F DB and 66.2°F WB in cooling and 68°F DB in heating.  
 Table does not reflect fan or pump power corrections for AHR/ISO conditions.  
 All performance is based upon the lower voltage of dual voltage rated units.  
 Performance stated is at the rated power supply; performance may vary as the power supply varies from the rated.  
 Operation below 40°F EWT is based upon a 15% methanol antifreeze solution.  
 Operation below 60°F EWT requires optional insulated water/refrigerant circuit.  
 See performance correction tables for operating conditions other than those listed above.  
 See Performance Data Selection Notes for operation in the shaded areas.  
 For additional pressure drop of unit options, see table on page 19.

Performance Data - HKV240

8000 CFM Nominal Airflow Heating & Cooling

Performance capacities shown in thousands of Btu/h

WATER/BRINE				Cooling - EAT 80/67°F					Heating - EAT 70°F				
EWT °F	FLOW gpm	PD psi	PD ft.	TC	SC	kW	HR	EER	HC	kW	HE	LAT	COP
<b>20</b>	60.0	11.4	26.4	Operation not recommended					164.1	15.5	111.3	86.7	3.1
<b>30</b>	30.0	2.4	5.4	284.5	194.1	12.5	327.2	22.8	177.5	15.7	123.8	88.3	3.3
	45.0	5.9	13.7	288.5	194.0	12.0	329.4	24.1	184.1	15.9	129.9	89.0	3.4
	60.0	10.5	24.3	289.9	193.3	11.7	329.9	24.7	187.8	16.0	133.3	89.4	3.4
<b>40</b>	30.0	2.1	4.9	277.2	192.1	13.3	322.6	20.8	201.9	16.3	146.3	91.0	3.6
	45.0	5.4	12.5	283.0	193.8	12.7	326.4	22.3	210.7	16.5	154.5	92.1	3.7
	60.0	9.7	22.3	285.5	194.2	12.4	327.9	23.0	215.6	16.6	159.1	92.6	3.8
<b>50</b>	30.0	1.9	4.5	267.8	188.1	14.2	316.3	18.8	228.9	16.9	171.2	94.1	4.0
	45.0	4.9	11.4	274.9	191.1	13.5	321.1	20.2	240.0	17.1	181.6	95.4	4.1
	60.0	9.2	21.1	278.2	192.3	13.2	323.3	21.0	246.2	17.3	187.4	96.1	4.2
<b>60</b>	30.0	1.4	3.3	256.7	182.8	15.3	308.8	16.7	259.3	17.6	199.4	97.3	4.3
	45.0	4.2	9.7	264.8	186.6	14.5	314.3	18.1	272.8	17.8	212.0	98.9	4.5
	60.0	7.9	18.2	268.6	188.3	14.2	316.9	18.9	280.3	18.0	219.0	99.7	4.6
<b>70</b>	30.0	1.3	3.0	244.2	176.4	16.5	300.5	14.7	291.1	18.3	228.8	100.7	4.7
	45.0	3.9	9.1	252.7	180.6	15.6	306.1	16.0	306.8	18.6	243.4	102.4	4.8
	60.0	7.5	17.4	256.9	182.7	15.2	308.9	16.7	315.4	18.8	251.3	103.4	4.9
<b>80</b>	30.0	1.2	2.7	230.7	169.9	17.9	291.8	12.8	320.9	18.9	256.5	104.0	5.0
	45.0	3.7	8.6	239.3	174.1	17.0	297.1	14.0	338.3	19.3	272.5	106.0	5.1
	60.0	7.2	16.5	243.5	176.2	16.5	299.8	14.7	347.7	19.5	281.0	107.0	5.2
<b>85</b>	30.0	1.2	2.7	223.8	166.9	18.7	287.7	11.9	339.9	19.4	273.6	105.7	5.1
	45.0	3.7	8.5	232.3	170.9	17.7	292.7	13.1	349.2	19.1	284.0	107.7	5.2
	60.0	7.0	16.3	236.6	173.0	17.2	295.4	13.7	354.3	19.0	289.7	108.7	5.3
<b>90</b>	30.0	1.1	2.6	216.9	163.9	19.5	283.5	11.1	358.8	20.0	290.7	107.3	5.2
	45.0	3.6	8.3	225.4	167.7	18.5	288.3	12.2	360.1	18.9	295.6	109.4	5.4
	60.0	7.0	16.1	229.7	169.8	17.9	291.0	12.7	361.0	18.4	298.3	110.4	5.4
<b>100</b>	30.0	1.1	2.4	204.2	158.6	21.3	277.0	9.5	Operation not recommended				
	45.0	3.5	8.1	212.2	161.8	20.2	281.0	10.5					
	60.0	6.7	15.6	216.3	163.6	19.6	283.3	11.0					
<b>110</b>	30.0	1.0	2.3	192.2	154.4	23.4	272.2	8.1					
	45.0	3.4	7.8	199.5	156.8	22.1	275.0	9.0					
	60.0	6.5	15.1	203.3	158.3	21.5	276.7	9.4					
<b>120</b>	30.0	0.9	2.2	181.2	151.9	25.8	269.4	7.0					
	45.0	3.3	7.6	187.6	153.2	24.4	270.8	7.6					
	60.0	6.3	14.6	191.0	154.1	23.7	271.8	8.0					

Interpolation is permissible; extrapolation is not.  
 All entering air conditions are 80°F DB and 67°F WB in cooling, and 70°F DB in heating.  
 AHRI/ISO certified conditions are 80.6°F DB and 66.2°F WB in cooling and 68°F DB in heating.  
 Table does not reflect fan or pump power corrections for AHRI/ISO conditions.  
 All performance is based upon the lower voltage of dual voltage rated units.  
 Performance stated is at the rated power supply; performance may vary as the power supply varies from the rated.  
 Operation below 40°F EWT is based upon a 15% methanol antifreeze solution.  
 Operation below 60°F EWT requires optional insulated water/refrigerant circuit.  
 See performance correction tables for operating conditions other than those listed above.  
 See Performance Data Selection Notes for operation in the shaded areas.  
 For additional pressure drop of unit options, see table on page 19.

10000 CFM Nominal (Rated) Airflow

Performance capacities shown in thousands of Btuh

WATER/BRINE				Cooling - EAT 80/67°F					Heating - EAT 70°F				
EWT °F	FLOW gpm	PD psi	PD ft.	TC	SC	kW	HR	EER	HC	kW	HE	LAT	COP
<b>20</b>	76.0	13.5	31.2	Operation not recommended					211.0	20.5	141.0	87.1	3.0
<b>30</b>	38.0	3.1	7.1	350.0	263.5	16.7	406.9	21.0	230.1	21.1	158.2	88.9	3.2
	56.0	7.0	16.1	347.6	276.0	15.9	401.7	22.0	238.9	21.3	166.1	89.7	3.3
	76.0	12.4	28.7	344.6	283.3	15.4	397.1	22.4	244.3	21.5	171.0	90.1	3.3
<b>40</b>	38.0	2.6	6.1	347.1	247.7	17.8	408.0	19.4	262.9	22.0	188.0	91.8	3.5
	56.0	6.3	14.5	349.7	258.0	17.0	407.7	20.5	274.3	22.2	198.5	92.9	3.6
	76.0	11.3	26.2	349.8	264.4	16.6	406.2	21.1	281.3	22.4	204.9	93.5	3.7
<b>50</b>	38.0	2.4	5.6	338.5	235.2	19.1	403.5	17.7	298.0	22.8	220.3	95.0	3.8
	56.0	5.9	13.6	344.8	243.3	18.2	406.8	18.9	312.0	23.1	233.2	96.3	4.0
	76.0	10.7	24.7	347.3	248.4	17.7	407.7	19.5	320.6	23.3	241.2	97.1	4.0
<b>60</b>	38.0	1.9	4.3	325.9	225.3	20.4	395.4	15.9	335.8	23.7	255.0	98.3	4.2
	56.0	4.8	11.2	334.7	231.6	19.4	401.0	17.1	352.3	24.0	270.3	99.8	4.3
	76.0	9.1	20.9	338.9	235.6	18.9	403.5	17.8	362.3	24.3	279.5	100.7	4.4
<b>70</b>	38.0	1.7	4.0	311.0	217.0	21.9	385.7	14.1	374.2	24.6	290.2	101.7	4.5
	56.0	4.6	10.6	321.2	222.1	20.9	392.5	15.3	392.7	25.0	307.2	103.3	4.6
	76.0	8.7	20.1	326.6	225.2	20.3	396.0	15.9	403.7	25.3	317.3	104.3	4.7
<b>80</b>	38.0	1.6	3.6	294.4	209.7	23.7	375.1	12.4	410.4	25.5	323.4	104.9	4.7
	56.0	4.3	9.9	305.2	214.1	22.5	382.1	13.5	430.1	26.0	341.3	106.7	4.8
	76.0	8.3	19.2	311.2	216.7	21.9	386.0	14.1	441.6	26.4	351.6	107.7	4.9
<b>85</b>	38.0	1.6	3.5	285.8	206.4	24.7	370.0	11.5	427.6	26.0	339.0	106.5	4.8
	56.0	4.3	9.8	296.5	210.6	23.5	376.6	12.6	447.4	26.6	356.7	108.2	4.9
	76.0	8.2	18.9	302.5	213.1	22.9	380.5	13.2	458.7	27.0	366.7	109.3	5.0
<b>90</b>	38.0	1.5	3.4	277.1	203.1	25.7	364.9	10.7	444.9	26.5	354.6	108.0	4.9
	56.0	4.2	9.6	287.8	207.1	24.4	371.2	11.7	464.7	27.1	372.1	109.8	5.0
	76.0	8.1	18.7	293.9	209.4	23.8	375.0	12.3	475.8	27.6	381.7	110.8	5.1
<b>100</b>	38.0	1.4	3.2	260.7	196.9	28.0	356.3	9.3	Operation not recommended				
	56.0	4.0	9.3	270.5	200.6	26.6	361.2	10.1					
	76.0	7.9	18.1	276.3	202.8	25.8	364.4	10.7					
<b>110</b>	38.0	1.3	3.0	246.0	191.0	30.7	350.9	8.0					
	56.0	3.9	9.0	254.4	194.5	29.1	353.6	8.7					
	76.0	7.6	17.6	259.5	196.5	28.2	355.8	9.2					
<b>120</b>	38.0	1.2	2.9	234.6	186.0	33.9	350.4	6.9					
	56.0	3.7	8.6	240.8	188.8	32.0	349.9	7.5					
	76.0	7.4	17.1	244.9	190.6	31.0	350.6	7.9					

Interpolation is permissible; extrapolation is not.  
 All entering air conditions are 80°F DB and 67°F WB in cooling, and 70°F DB in heating.  
 AHRI/ISO certified conditions are 80.6°F DB and 66.2°F WB in cooling and 68°F DB in heating.  
 Table does not reflect fan or pump power corrections for AHRI/ISO conditions.  
 All performance is based upon the lower voltage of dual voltage rated units.  
 Performance stated is at the rated power supply; performance may vary as the power supply varies from the rated.  
 Operation below 40°F EWT is based upon a 15% methanol antifreeze solution.  
 Operation below 60°F EWT requires optional insulated water/refrigerant circuit.  
 See performance correction tables for operating conditions other than those listed above.  
 See Performance Data Selection Notes for operation in the shaded areas.  
 For additional pressure drop of unit options, see table on page 19.

# HKV Performance Data Correction Tables

## Air Flow Correction Table

Percentage of Rated Airflow	Cooling				Heating		
	Total Capacity	Sensible Capacity	Power	Heat of Rejection	Heating Capacity	Power	Heat of Extraction
<b>75%</b>	0.957	0.868	0.944	0.954	0.960	1.045	0.938
<b>81%</b>	0.970	0.901	0.957	0.967	0.971	1.027	0.956
<b>88%</b>	0.982	0.940	0.971	0.980	0.983	1.015	0.974
<b>94%</b>	0.991	0.970	0.985	0.990	0.991	1.007	0.987
<b>100%</b>	1.000	1.000	1.000	1.000	1.000	1.000	1.000
<b>106%</b>	1.002	1.025	1.013	1.004	1.006	0.999	1.009
<b>113%</b>	1.004	1.050	1.026	1.009	1.013	0.998	1.019
<b>119%</b>	1.008	1.073	1.042	1.015	1.021	0.997	1.028
<b>125%</b>	1.013	1.095	1.058	1.022	1.029	0.996	1.038

## Entering Air Correction Tables

Entering Air DB°F	Heating Capacity	Power	Heat of Extraction	Entering Air WB°F	Total Capacity	Sensible Cooling Capacity Multiplier - Entering DB °F							Power	Heat of Rejection	
						65	70	75	80	80.6	85	90			95
50	1.034	0.843	1.087												
55	1.027	0.877	1.068												
60	1.022	0.916	1.051												
65	1.010	0.957	1.025												
68	1.004	0.982	1.010												
70	1.000	1.000	1.000												
75	0.991	1.045	0.976												
80	0.982	1.101	0.948												
				55.0	0.953	0.909	*	*	*	*	*	*	*	0.988	0.960
				60.0	0.954	0.760	0.810	1.076	1.209	1.233	*	*	*	0.991	0.962
				65.0	0.975		0.644	0.872	1.089	1.115	1.238	*	*	0.995	0.979
				66.2	0.988		0.594	0.818	1.036	1.064	1.198	*	*	0.998	0.990
				67.0	1.000		0.568	0.782	1.000	1.027	1.164	1.350	1.421	1.000	1.000
				70.0	1.045			0.647	0.864	0.889	1.034	1.295	1.421	1.009	1.037
				75.0	1.122				0.638	0.658	0.806	1.076	1.294	1.025	1.103

\* = Sensible capacity equals total capacity  
 AHRI/ISO/ASHRAE 13256-1 uses entering air conditions of Cooling - 80.6°F DB/66.2°F WB, 1 and Heating - 68°F DB/59°F WB entering air temperature

## Antifreeze Correction and Water Pressure Drop Adder for Option Tables

Antifreeze Type	Antifreeze %	Cooling			WPD Corr. Fct. EWT 40°F
		EWT 40°F			
		Total Cap	Sens Cap	Power	
Propylene Glycol	15	0.968	0.968	0.990	1.210
	25	0.947	0.947	0.983	1.360
Methanol	15	0.968	0.968	0.990	1.160
	25	0.949	0.949	0.984	1.220
Ethanol	15	0.944	0.944	0.983	1.300
	25	0.917	0.917	0.974	1.360
Ethylene Glycol	15	0.980	0.980	0.994	1.120
	25	0.966	0.966	0.990	1.200

### Options Pressure Drop Table

Model	GPM	Motorized Water Valve Option			ClimaDry® Option	
		CV	PSI	FT	PSI	FT
084	10.50	41	0.08	1.8	0.80	1.8
	15.75	41	1.80	4.2	1.80	4.2
	21.00	41	3.20	7.4		
096	12.00	41	1.40	3.2	0.89	2.1
	18.00	41	3.20	7.4	2.01	4.6
	24.00	41	5.80	13.4		
120	15.00	41	1.00	2.3	1.39	3.2
	22.50	41	2.30	5.3	3.13	7.2
	30.00	41	4.00	9.2		
150	19.00	57	0.33	0.8	2.23	5.2
	28.00	57	0.49	1.1	4.85	11.2
	38.00	57	0.67	1.5		
168	21.00	57	0.37	0.9	1.85	4.3
	34.50	57	0.61	1.4	4.17	9.6
	42.00	57	0.74	1.7		
192	24.00	57	0.42	1.0	1.85	4.3
	36.00	57	0.63	1.5	4.16	9.6
	48.00	57	0.84	1.9		
240	30.00	57	0.53	1.2	2.89	6.7
	45.00	57	0.79	1.8	6.50	15.0
	60.00	57	1.05	2.4		
300	38.00	57	0.67	1.5	4.64	10.7
	56.00	57	0.98	2.3	10.07	23.3
	76.00	57	1.33	3.1		

Operation in the shaded area is not recommended.

# ClimaDry® II Options, Benefits, and Applications

## ClimaDry® II Modulating Reheat Option

Comfort-Aire/Century's patented ClimaDry® II Dehumidification option is an innovative means of providing modulating reheat without the complication of refrigeration controls. ClimaDry® II is hot gas generated reheat, which utilizes one of the biggest advantages of a Water-Source Heat Pump (WSHP), the transfer of energy through the water piping system. ClimaDry® II simply diverts condenser water through a water-to-air coil that is placed after the evaporator coil. If condenser water is not warm enough, the internal "run-around" loop increases the water temperature with each pass through the condenser coil.

## ClimaDry® II Benefits

ClimaDry® II is like no other reheat option on the market. Proportional reheat is controlled to the desired leaving air temperature setpoint (factory setpoint of 72°F, 22°C), no matter what the water loop temperature is. Since dehumidification operation will occur under less than full load cooling conditions a good percentage of the time, it is important to have a reheat function that provides 100% reheat in the spring and fall when the water loop is cool. Supply air temperature is field adjustable to +/- 3°F [+/- 1.7°C] for even greater flexibility with the optional potentiometer. It is recommended that the ClimaDry® supply air temperature be set to match the space cooling setpoint so that ClimaDry® does not impact room temperature. Competitors without ClimaDry® II typically use an on/off (non-modulating) refrigeration based reheat circuit, typically referred to as "Hot gas reheat" (HGR).

HGR needs higher condensing temperatures to work well, typically 85°F [29°C] entering water temperature (EWT). With HGR, cooler water temperatures produce cooler supply air temperatures, which could overcool the space, requiring additional space heating from another source or a special auto-change-over relay to allow the unit to switch back and forth between reheat and heating. Rarely does HGR provide 100% reheat, like ClimaDry® II. ClimaDry® II has a simple and easy to troubleshoot refrigerant circuit. No switching valves or hard to diagnose leaky check valves are utilized. No unusual refrigerant pressures occur during the reheat mode. The ClimaDry® II refrigerant circuit is like every other Comfort-Aire/Century unit (without reheat), so everything the technician already knows applies to troubleshooting the ClimaDry® II refrigeration circuit. Plus, the water loop portion of the ClimaDry® II option is easy to understand and diagnose.

## ClimaDry® II Applications

ClimaDry® II can be applied to a number of common applications, such as:

- Classrooms.
- Condominiums.
- Apartments.
- Computer rooms.
- Spaces with high latent loads like auditoriums, theaters, convention centers, etc.
- Most applications where humidity is a problem.

**(Note: ClimaDry® is not for use in high fraction outdoor air applications or in applications with**

## ClimaDry® II Schematic

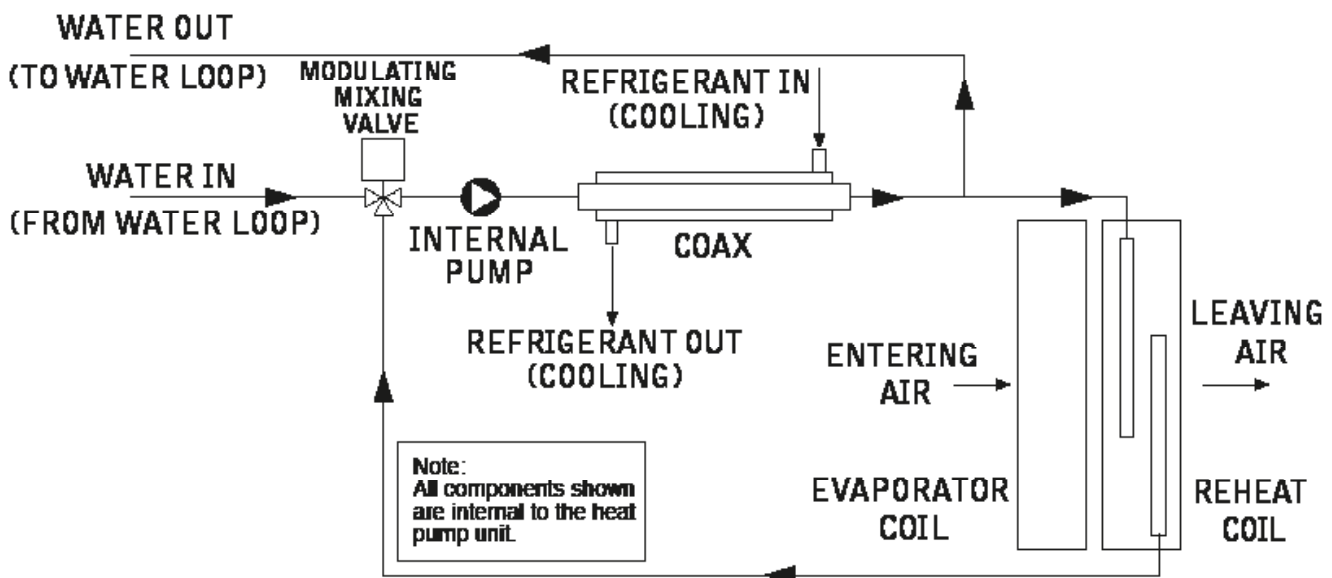

# ClimaDry® II Options, Benefits, and Applications

With the ClimaDry® II option, return air from the space is cooled by the air-to-refrigerant (evaporator) coil, and then reheated by the water-to-air (reheat) coil to dehumidify the air, but maintain the same space temperature (thus operating as a dehumidifier).

The moisture removal capability of the heat pump is determined by the unit's latent capacity rating. Latent capacity equals Total capacity minus Sensible capacity. Using unit performance data from submittals, select the correct model, use your maximum entering water temperature (EWT) and flow rate to select TC and SC. For example, at 80°F [26.7°C] EWT and 15 GPM, the moisture removal capability (latent capacity) of a Comfort-Aire/Century HKV120 is 30.4 Mbtuh [8.8kW].

Dividing the latent capacity by 1,069 BTU/LB of water vapor at 80°F DB and 67°F WB [26.7°C DB and 19.4°C WB] moist air enthalpy, converts the amount of moisture removal to pounds per hour (multiply pounds per hour by 0.4536 to obtain kg/hr). Calculations are shown in figure 1.

Most Comfort-Aire/Century heat pumps have a sensible-to-total (S/T) ratio of 0.72 to 0.82. Therefore, approximately, 25% of the cooling capacity is dedicated to latent cooling capacity (moisture removal). When selecting a unit with ClimaDry® II, the space sensible and latent loads should be calculated. If the unit will be used for space cooling, a unit with at least enough capacity to satisfy the building sensible load should be selected. If the latent cooling load is not satisfied by the selection, a larger unit with enough latent capacity will be required. If the unit will be used for dehumidification purposes only, the latent capacity is the only consideration necessary. In this case, sensible load is immaterial.

Figure 1: Example HKV120 Performance

**LC = TC - SC = 115.4 - 85.0 = 30.4 Mbtuh**  
**30,400 Btuh ÷ 1069 = 28.4 lbs/hr (12.9 kg/hr)**

4000 CFM Minimum Airflow Heating & Cooling

WATER/REFINE				Cooling - EAT 80/67°F					Heating - EAT 70°F				
EWT °F	FLOW GPM	PD psi	PD ft	TC	SC	kW	HFL	EER	HC	kW	HE	LAT	COP
80	15.00	1.1	2.4	115.4	85.0	9.0	148.8	12.9	100.5	9.4	139.2	105.9	6.0
	15.00	3.3	7.6	119.0	87.5	8.6	148.5	14.1	100.1	9.9	139.2	108.9	6.1
	30.00	6.4	14.7	121.9	88.1	8.2	148.8	14.9	173.8	9.9	140.6	108.7	6.8
85	15.00	1.1	2.4	111.9	85.0	9.4	148.8	12.9	100.8	9.7	139.6	108.9	6.1
	15.00	3.3	7.4	116.2	86.0	8.9	148.4	13.2	174.5	9.6	142.0	110.0	6.4
	30.00	6.3	14.4	119.3	86.0	8.9	147.7	13.8	177.2	9.6	144.6	111.4	6.8
90	15.00	1.0	2.3	108.5	81.8	9.6	141.7	11.1	176.4	10.0	145.2	111.4	6.2
	15.00	3.2	7.4	112.7	83.8	9.2	144.2	12.2	180.9	9.4	147.6	112.6	6.6
	30.00	6.2	14.3	114.9	84.8	9.0	145.5	12.8	182.5	9.2	149.1	113.1	6.6
100	15.00	0.9	2.2	102.1	79.3	10.7	138.5	9.5	Operation Not Recommended				
	15.00	3.1	7.2	105.1	80.8	10.1	140.5	10.5					
	30.00	6.0	13.9	108.2	81.8	9.6	141.5	11.0					
110	15.00	0.9	2.0	95.1	77.8	11.7	135.1	8.2					
	15.00	3.0	6.9	98.7	78.4	11.1	137.5	8.9					
	30.00	6.6	13.4	101.7	79.1	10.6	138.4	8.5					
120	15.00	0.8	1.9	89.5	76.6	12.9	131.7	7.3					
	15.00	2.9	6.7	93.8	76.6	12.2	135.4	7.7					
	30.00	6.0	13.0	95.5	77.5	11.8	135.8	8.1					

Dividing the latent capacity by 1,069 BTU/LB of water vapor at 80°F DB and 67°F WB [26.7°C DB and 19.4°C WB] moist air enthalpy, converts the amount of moisture removal to pounds per hour (multiply pounds per hour by 0.4536 to obtain kg/hr). Calculations are shown in figure 1.

Note: Minimum entering air temperature of 70°F DB / 61°F WB

## ClimaDry® II Sequence of Operation

**ClimaDry® II Sequence of Operation** - A heat pump equipped with ClimaDry® II can operate in three modes; cooling, cooling with reheat (dehumidification), and heating. The cooling/heating modes are like any other Comfort-Aire/Century WSHP. The reversing valve ("O" signal) is energized in cooling, along with the compressor contactor(s) and blower relay. In the heating mode the reversing valve is de-energized. Almost any thermostat will activate the heat pump in heating or cooling modes. The DXM2 microprocessor board, which is required with the ClimaDry® II option, will accept either heat pump (Y,O) thermostats or non-heat pump (Y,W) thermostats. The reheat mode requires either a separate humidistat/dehumidistat or a thermostat that has an integrated dehumidification function for activation. The DXM2 board is configured to work with either a humidistat or dehumidistat input to terminal "H". Upon receiving an "H" input, the DXM2 board will activate the cooling mode and engage reheat. There are four operational inputs for single stage units and six

operational inputs for dual stage units:

- Fan Only
- 1st Stage Cooling
- 2nd Stage Cooling
- 1st Stage Heating
- 2nd Stage Heating
- Reheat Mode

**Fan Only:** A (G) call from the thermostat to the (G) terminal of the DXM2 control board will bring the unit on in fan only mode.

**1st Stage Cooling:** A simultaneous call from (G), (Y1), and (O) to the (G), (Y1), (O/W2) terminals of the DXM2 control board will bring the unit on in 1st Stage Cooling.

**2nd Stage Cooling:** A simultaneous call from (G), (Y1), (Y2), and (O) to the (G), (Y1), (Y2), and (O/W2) terminals of the DXM2 control board will bring the unit on in 2nd Stage Cooling. When the call is satisfied at the thermostat the unit will continue to run in 1st Stage Cooling until the 1st Stage

### Humidistat/Dehumidistat Logic and DXM2 (2.1, 2.2., 2.3) DIP Settings

Sensor	2.1	2.2	2.3	Logic	Reheat (ON) - H	Reheat (OFF) - H
Humidistat	OFF	OFF	OFF	Reverse	0 VAC	24 VAC
Dehumidistat	OFF	ON	OFF	Standard	24 VAC	0 VAC

### ClimaDry® II Operating Modes

Mode	Input					Output				
	O	G	Y1	Y2 <sup>3</sup>	H	O	G	Y1	Y2 <sup>3</sup>	Reheat
No Demand	ON/OFF	OFF	OFF	OFF	OFF	ON/OFF	OFF	OFF	OFF	OFF
Fan Only	ON/OFF	ON	OFF	OFF	OFF	ON/OFF	ON	OFF	OFF	OFF
Cooling 1st Stage	ON	ON	ON	OFF	OFF	ON	ON	ON	OFF	OFF
Cooling 2nd Stage	ON	ON	ON	ON	OFF	ON	ON	ON	ON	OFF
Cooling & Dehumidistat <sup>1</sup>	ON	ON	ON	ON/OFF	ON	ON	ON	ON	ON/OFF	OFF
Dehumidistat Only	ON/OFF	OFF	OFF	OFF	ON	ON	ON	ON	ON	ON
Heating 1st Stage	OFF	ON	ON	OFF	OFF	OFF	ON	ON	OFF	OFF
Heating 2nd Stage	OFF	ON	ON	ON	OFF	OFF	ON	ON	ON	OFF
Heating & Dehumidistat <sup>2</sup>	OFF	ON	ON	ON/OFF	ON	OFF	ON	ON	ON/OFF	OFF

<sup>1</sup>Cooling input takes priority over dehumidify input.

<sup>2</sup>DXM2 is programmed to ignore the H demand when the unit is in heating mode.

<sup>3</sup>N/A for single stage units; Full load operation for dual capacity units.

<sup>4</sup>ON/OFF = Either ON or OFF.

## ClimaDry® II Sequence of Operation

Cooling call is removed or satisfied, shutting down the unit. **NOTE: Not all units have two-stage cooling functionality.**

1st Stage Heating: A simultaneous call from (G) and (Y1) to the (G) and (Y1) terminals of the DXM2 control board will bring the unit on in 1st Stage Heating.

2nd Stage Heating: A simultaneous call from (G), (Y1), and (Y2) to the (G), (Y1), and (Y2) terminals of the DXM2 control board will bring the unit on in 2nd Stage Heating. When the call is satisfied at the thermostat the unit will continue to run in 1st Stage Heating until the call is removed or satisfied, shutting down the unit. **NOTE: Not all units have two-stage heating functionality (e.g. TLV084-150 units).**

Reheat Mode: A call from the Humidistat/Dehumidistat to the (H) terminal of the DXM2 control board will bring the unit on in Reheat Mode if there is no call for cooling at the thermostat. When the Humidistat/Dehumidification call is removed or satisfied the unit will shut down. **NOTE: Cooling always overrides Reheat Mode. In the Cooling mode, the unit cools and dehumidifies. If the cooling thermostat is satisfied but there is still a call for dehumidification, the unit will continue to operate in Reheat Mode.**

**Note: Care must be taken when using a humidistat to operate ClimaDry®. When the DIP switch on the DXM2 controller is set for 'humidistat' it reverses the control logic so that an "open" control circuit initiates a ClimaDry® run cycle. If a humidistat is not connected, or if a manual switch on the humidistat is set to "off", ClimaDry® will see the open circuit and call for dehumidification.**

### ClimaDry® II Component Functions

The ClimaDry® II option consists of the following components:  
 Motorized Valve/Proportional Controller  
 Supply Air Sensor  
 Loop Pump  
 Hydronic Coil  
 Low Air Temperature Switch

The Proportional Controller operates on 24 VAC power supply and automatically adjusts the water valve based upon the Supply Air Sensor. The Supply Air Sensor senses

supply air temperature at the blower inlet providing the input signal necessary for the proportional control to drive the motorized valve during the reheat mode of operation. The Motorized Valve is a proportional actuator/three-way valve combination used to divert the condenser water from the coax to the hydronic reheat coil during the reheat mode of operation. The proportional controller signals the motorized valve based on the supply air temperature of the supply air sensor.

The Loop Pump circulates condenser water through the hydronic reheat coil during the reheat mode of operation. In this application, the loop pump is only energized during the reheat mode of operation. The Hydronic Coil is utilized during the reheat mode of operation to reheat the air to the setpoint of the proportional controller. Condenser water is diverted by the motorized valve and pumped through the hydronic coil by the loop pump in proportion to the control setpoint. The amount of reheating is dependent on the setpoint and how far from setpoint the supply air temperature is. The factory setpoint is 72°F [22°C], generally considered "neutral" air.

### ClimaDry® II Application Considerations

The reheat coil adds a small amount of resistance to the air stream. In some cases the high static option may be required for applications with higher static ductwork. Consult the submittal data or the Installation/Operation/Maintenance (I.O.M.) manual for the specific heat pump to review blower tables.

Unlike most hot gas reheat options, the ClimaDry® II option will operate over a wide range of EWTs. Special flow regulation (water regulating valve) is not required for low EWT conditions.

Unit minimum entering air temperature while in the dehumidification, cooling, or continuous fan modes is **65°F DB/55°F WB**. Operation below this minimum may result in nuisance faults.

**Water-source heat pumps with ClimaDry® II should not be used as make-up air units. These applications should use equipment specifically designed for make-up air.**

# Blower Performance Data - HKV084 - Standard Unit - No ClimaDry®

All Data is Wet Coil

Airflow (SCFM)	ESP	Airflow (cfm) at External Static Pressure (in. wg)																	
		0.00	0.10	0.20	0.30	0.40	0.50	0.60	0.70	0.80	0.90	1.00	1.10	1.20	1.30	1.40	1.50		
2100	BHP			0.24	0.29	0.34	0.37	0.41	0.44	0.49	0.54	0.59	0.64	0.69	0.74	0.79	0.84		
	Sheave/Mtr			B	B	B	A	A	A	A	A	A	C	C	C	C	C		
	RPM			410	457	499	537	577	612	647	678	710	737	764	791	815	838		
	Turns Open			5	3.5	4.5	6	5	4	3	2.5	1.5	6	5.5	4.5	4	3		
2200	BHP			0.28	0.315	0.34	0.39	0.44	0.49	0.54	0.59	0.64	0.69	0.74	0.79	0.84	0.9		
	Sheave/Mtr			B	B	B	A	A	A	A	A	A	C	C	C	C	C		
	RPM			424	467	507	548	584	621	653	684	716	743	772	797	821	847		
	Turns Open			4.5	3.5	4.5	5.5	5	4	3	2	1.5	6	5	4.5	3.5	3		
2300	BHP			0.29	0.34	0.39	0.44	0.49	0.54	0.59	0.64	0.69	0.74	0.79	0.84	0.89	0.94		
	Sheave/Mtr			B	B	B	A	A	A	A	A	A	C	C	C	C	C		
	RPM			435	476	518	555	590	627	659	692	721	751	777	803	829	853		
	Turns Open			4.5	3	4	5.5	4.5	3.5	2.5	2	1.5	5.5	5	4	3.5	2.5		
2400	BHP		0.29	0.34	0.39	0.44	0.49	0.54	0.59	0.64	0.69	0.74	0.79	0.84	0.89	0.94	0.99		
	Sheave/Mtr			B	B	B	A	A	A	A	A	A	C	C	C	C	C		
	RPM			403	446	485	527	563	600	633	665	697	726	756	783	811	835	858	
	Turns Open			5	4	3	6	5.5	4.5	3.5	2.5	1.5	1	5.5	4.5	4	3	2.5	
2500	BHP		0.31	0.34	0.39	0.44	0.49	0.54	0.59	0.64	0.74	0.79	0.84	0.89	0.94	0.99	1.04		
	Sheave/Mtr			B	B	B	A	A	A	A	A	A	C	C	C	C	E		
	RPM			411	452	495	532	567	604	636	670	700	729	759	786	813	838	864	
	Turns Open			5	4	2.5	6	5.5	4	3.5	2.5	1.5	1	5.5	4.5	3.5	3	2.5	
2600	BHP		0.34	0.43	0.48	0.53	0.58	0.63	0.68	0.73	0.78	0.83	0.88	0.93	1.03	1.08	1.13		
	Sheave/Mtr			B	B	B	A	A	A	A	A	A	C	C	E	E	E		
	RPM			420	460	500	536	570	606	638	671	701	729	759	786	814	839	865	
	Turns Open			4.5	3.5	2.5	6	5	4	3	2	1.5	1	5	4	4	3	2.5	
2700	BHP		0.38	0.43	0.48	0.53	0.59	0.64	0.69	0.74	0.79	0.84	0.89	0.94	1.04	1.09	1.14		
	Sheave/Mtr			B	B	B	A	A	A	A	A	A	C	C	E	E	E		
	RPM			423	463	504	539	576	609	641	674	703	734	762	788	816	841	867	
	Turns Open			4.5	3.5	2	5.5	5	4	3	2	1.5	1	5	4	4	3	2.5	
2800	BHP		0.39	0.44	0.49	0.54	0.64	0.69	0.74	0.79	0.84	0.89	0.94	1.04	1.09	1.12	1.22		
	Sheave/Mtr			B	B	B	A	A	A	A	A	C	C	E	E	E	E		
	RPM			431	474	510	545	581	613	647	677	706	737	764	793	818	843	869	
	Turns Open			4.5	3	2	5.5	5	4	3	2	1.5	5.5	1	4.5	4	3	2.5	
2900	BHP		0.44	0.49	0.54	0.59	0.64	0.74	0.79	0.84	0.89	0.94	1.04	1.09	1.14	1.19	1.24		
	Sheave/Mtr			B	B	B	A	A	A	A	A	C	E	E	E	E	E		
	RPM			440	481	517	551	586	618	651	681	710	740	767	795	821	845	872	
	Turns Open			4	3	2	5.5	4.5	3.5	2.5	1.5	1	5.5	5.5	4.5	3.5	3	2	
3000	BHP	0.43	0.49	0.54	0.59	0.64	0.69	0.74	0.84	0.89	0.94	1.04	1.09	1.14	1.19	1.24	1.29		
	Sheave/Mtr			B	B	B	A	A	A	A	A	D	E	E	E	E	E		
	RPM			412	455	492	526	563	595	628	658	687	718	745	774	800	826	852	876
	Turns Open			5	3.5	2.5	6	5.5	4.5	3.5	2.5	1.5	1.5	1	5	4.5	3.5	3	2
3100	BHP	0.44	0.53	0.59	0.64	0.69	0.74	0.84	0.89	0.94	0.99	1.04	1.14	1.19	1.24	1.34	1.39		
	Sheave/Mtr			B	B	B	A	A	A	A	A	D	E	E	E	E	E		
	RPM			421	459	499	533	569	600	633	663	691	722	749	777	803	828	854	878
	Turns Open			4.5	3.5	2.5	6	5	4	3	2	1.5	1.5	1	5	4	3.5	2.5	2
3200	BHP	0.49	0.54	0.64	0.69	0.74	0.84	0.89	0.94	0.99	1.04	1.14	1.19	1.24	1.34	1.39	1.44		
	Sheave/Mtr			B	B	B	A	A	A	A	D	E	E	E	E	E	E		
	RPM			441	478	513	549	581	614	644	672	703	730	759	785	810	837	861	887
	Turns Open			4	3	2	5.5	5	4	3	2	1.5	1.5	5.5	4.5	4	3	2.5	2
3300	BHP	0.54	0.64	0.69	0.74	0.83	0.89	0.94	0.99	1.04	1.14	1.23	1.29	1.34	1.44	1.49			
	Sheave/Mtr			B	B	A	A	A	A	D	D	E	E	E	E	E			
	RPM			456	495	529	561	595	625	656	685	712	741	767	795	820	844	870	
	Turns Open			3.5	2.5	6	5	4.5	3.5	2.5	2	1.5	1	5	4.5	3.5	3	2.5	
3400	BHP	0.63	0.69	0.74	0.79	0.84	0.94	0.99	1.04	1.14	1.19	1.24	1.34	1.44	1.49				
	Sheave/Mtr			B	B	A	A	A	A	D	D	E	E	E	E				
	RPM			471	506	539	574	604	633	664	692	721	747	773	800	825	851		
	Turns Open			3	2	5.5	5	4	3.5	2.5	2	1.5	1	5	4	3.5	2.5		
3500	BHP	0.64	0.74	0.79	0.84	0.94	0.99	1.04	1.14	1.23	1.29	1.34	1.44	1.49					
	Sheave/Mtr			B	A	A	A	A	D	D	E	E	E	E					
	RPM			486	520	555	586	615	647	674	704	730	756	784	808	835			
	Turns Open			2.5	6	5.5	4.5	4	3	2.5	1.5	1	5.5	4.5	4	3			

A = Standard Static/Standard Motor, B = Low Static/Standard Motor, C = High Static/Standard Motor, D = Standard Static/Large Motor, E = High Static/Large Motor  
 Unit factory shipped with standard static sheave and drive at 2.5 turns open. Other speed require field selection.  
 For applications requiring higher static pressures, contact your local representative. Performance data does not include drive losses and is based on sea level conditions.  
 Do not operate in black regions. All airflow in rated at lowest Voltage if unit is dual Voltage rated, i.e. 208V for 208-230V units.

# Blower Performance Data - HKV096 - Standard Unit - No ClimaDry®

All Data is Wet Coil

Airflow (SCFM)	ESP	Airflow (cfm) at External Static Pressure (in. wg)																
		0.00	0.10	0.20	0.30	0.40	0.50	0.60	0.70	0.80	0.90	1.00	1.10	1.20	1.30	1.40	1.50	
2400	BHP		0.29	0.34	0.39	0.44	0.49	0.54	0.59	0.64	0.69	0.74	0.79	0.84	0.89	0.94	0.99	
	Sheave/Mtr		B	B	B	A	A	A	A	A	A	A	C	C	C	C	C	
	RPM		403	446	485	527	563	600	633	665	697	726	756	783	811	835	858	
	Turns Open		5	4	3	6	5.5	4.5	3.5	2.5	1.5	1	5.5	5	4	3.5	3	
2500	BHP		0.31	0.34	0.39	0.44	0.49	0.54	0.59	0.64	0.74	0.79	0.84	0.89	0.94	0.99	1.04	
	Sheave/Mtr		B	B	B	A	A	A	A	A	A	A	C	C	C	C	C	
	RPM		411	452	495	532	567	604	636	670	700	729	759	786	813	838	864	
	Turns Open		5	4	2.5	6	5.5	4	3.5	2.5	1.5	1	5.5	5	4	3	3	
2600	BHP		0.34	0.43	0.48	0.53	0.58	0.63	0.68	0.73	0.78	0.83	0.88	0.93	1.03	1.08	1.13	
	Sheave/Mtr		B	B	B	A	A	A	A	A	A	A	C	C	C	C	C	
	RPM		420	460	500	536	570	606	638	671	701	729	759	786	814	839	865	
	Turns Open		4.5	3.5	2.5	6	5	4	3	2	1.5	1	5	5	4	3	2.5	
2700	BHP		0.38	0.43	0.48	0.53	0.59	0.64	0.69	0.74	0.79	0.84	0.89	0.94	1.04	1.09	1.14	
	Sheave/Mtr		B	B	B	A	A	A	A	A	A	A	C	C	C	C	C	
	RPM		423	463	504	539	576	609	641	674	703	734	762	788	816	841	867	
	Turns Open		4.5	3.5	2	5.5	5	4	3	2	1.5	1	5	4.5	4	3	2.5	
2800	BHP		0.39	0.44	0.49	0.54	0.64	0.69	0.74	0.79	0.84	0.89	0.94	1.04	1.09	1.12	1.22	
	Sheave/Mtr		B	B	B	A	A	A	A	A	A	A	C	C	C	C	C	
	RPM		431	474	510	545	581	613	647	677	706	737	764	793	818	843	869	
	Turns Open		4.5	3	2	5.5	5	4	3	2	1.5	5.5	5	4.5	3.5	3	2.5	
2900	BHP		0.44	0.49	0.54	0.59	0.64	0.74	0.79	0.84	0.89	0.94	1.04	1.09	1.14	1.19	1.24	
	Sheave/Mtr		B	B	B	A	A	A	A	A	A	A	C	C	C	C	C	
	RPM		440	481	517	551	586	618	651	681	710	740	767	795	821	845	872	
	Turns Open		4	3	2	5.5	4.5	3.5	2.5	1.5	1	5.5	5	4.5	3.5	2.5	2.5	
3000	BHP	0.43	0.49	0.54	0.59	0.64	0.69	0.74	0.84	0.89	0.94	1.04	1.09	1.14	1.19	1.24	1.29	
	Sheave/Mtr		B	B	B	A	A	A	A	A	A	A	C	C	C	C	C	
	RPM		412	455	492	526	563	595	628	658	687	718	745	774	800	826	852	876
	Turns Open		5	3.5	2.5	6	5.5	4.5	3.5	2.5	1.5	1.5	6	5	4	3.5	2.5	2
3100	BHP		0.44	0.53	0.59	0.64	0.69	0.74	0.84	0.89	0.94	0.99	1.04	1.14	1.19	1.24	1.34	
	Sheave/Mtr		B	B	B	A	A	A	A	A	A	A	C	C	C	C	C	
	RPM		421	459	499	533	569	600	633	663	691	722	749	777	803	828	854	878
	Turns Open		4.5	3.5	2.5	6	5	4	3	2	1.5	1.5	6	4.5	4	3	2.5	2
3200	BHP		0.49	0.54	0.64	0.69	0.74	0.84	0.89	0.94	0.99	1.04	1.14	1.19	1.24	1.34	1.39	1.44
	Sheave/Mtr		B	B	B	A	A	A	A	A	A	A	C	C	C	C	C	
	RPM		441	478	513	549	581	614	644	672	703	730	759	785	810	837	861	887
	Turns Open		4	3	2	5.5	5	4	3	2	1.5	1.5	5.5	4.5	4	3	2.5	2
3300	BHP		0.54	0.64	0.69	0.74	0.83	0.89	0.94	0.99	1.04	1.14	1.23	1.29	1.34	1.44	1.49	1.54
	Sheave/Mtr		B	B	A	A	A	A	A	A	A	A	C	C	C	C	C	E
	RPM		456	495	529	561	595	625	656	685	712	741	767	795	820	844	870	893
	Turns Open		3.5	2.5	6	5	4.5	3.5	2.5	2	1.5	1	5	4.5	3.5	3	2	2
3400	BHP		0.63	0.69	0.74	0.79	0.84	0.94	0.99	1.04	1.14	1.23	1.29	1.34	1.44	1.49	1.54	1.64
	Sheave/Mtr		B	B	A	A	A	A	A	A	A	A	C	C	C	C	E	E
	RPM		471	506	539	574	604	633	664	692	721	747	773	800	825	851	875	898
	Turns Open		3	2	5.5	5	4	3.5	2.5	2	1.5	1	5	4	3.5	2.5	2.5	2
3500	BHP		0.64	0.74	0.79	0.84	0.94	0.99	1.04	1.14	1.23	1.29	1.34	1.44	1.49	1.54	1.64	1.74
	Sheave/Mtr		B	A	A	A	A	A	A	A	A	C	C	C	C	E	E	E
	RPM		486	520	555	586	615	647	674	704	730	756	784	808	835	858	883	906
	Turns Open		2.5	6	5.5	4.5	4	3	2.5	1.5	1	5.5	4.5	4	3	2.5	2.5	1.5
3600	BHP		0.74	0.79	0.84	0.94	0.99	1.04	1.14	1.19	1.24	1.34	1.44	1.49	1.54	1.64	1.74	1.83
	Sheave/Mtr		B	A	A	A	A	A	A	A	A	C	C	C	E	E	E	E
	RPM		495	528	562	593	624	652	680	708	734	762	787	812	838	861	886	909
	Turns Open		2.5	6	5	4.5	3.5	3	2	1.5	1	5.5	4.5	4	3	2.5	2.5	1.5
3700	BHP		0.79	0.84	0.93	0.99	1.04	1.14	1.19	1.24	1.34	1.44	1.49	1.54	1.64	1.74	1.79	1.84
	Sheave/Mtr		B	A	A	A	A	A	A	A	A	C	C	E	E	E	E	E
	RPM		506	541	572	605	633	661	690	716	744	769	793	820	843	868	891	913
	Turns Open		2	5.5	5	4	3.5	3	2	1.5	1	5	4.5	3.5	3	2.5	2	1.5
3800	BHP		0.84	0.89	0.94	1.04	1.13	1.19	1.24	1.34	1.43	1.49	1.54	1.64	1.73	1.79	1.84	1.94
	Sheave/Mtr		B	A	A	A	A	A	A	A	C	C	E	E	E	E	E	E
	RPM		515	549	580	611	640	667	696	721	749	773	798	823	847	872	894	918
	Turns Open		2	5.5	4.5	4	3.5	2.5	1.5	1.5	5.5	5	4	3.5	3	2.5	2	1
3900	BHP		0.89	0.94	1.04	1.09	1.14	1.24	1.34	1.39	1.44	1.54	1.64	1.69	1.74	1.84	1.94	
	Sheave/Mtr		A	A	A	A	A	A	A	A	C	E	E	E	E	E	E	
	RPM		525	556	586	617	645	674	701	726	753	778	804	827	850	875	897	
	Turns Open		6	5.5	4.5	4	3	2.5	1.5	1	5.5	5	4	3.5	2.5	2	2	
4000	BHP		0.94	1.04	1.09	1.14	1.24	1.34	1.44	1.49	1.54	1.64	1.74	1.79	1.84	1.94		
	Sheave/Mtr		A	A	A	A	A	A	A	A	E	E	E	E	E	E		
	RPM		539	569	601	629	659	685	711	738	763	789	812	835	860	882		
	Turns Open		5.5	5	4.5	3.5	3	2	1	1	5	4.5	3.5	3	2.5	2		

A = Standard Static/Standard Motor, B = Low Static/Standard Motor, C = High Static/Standard Motor, D = Standard Static/Large Motor, E = High Static/Large Motor  
 Unit factory shipped with standard static sheave and drive at 2.5 turns open. Other speed require field selection.  
 For applications requiring higher static pressures, contact your local representative. Performance data does not include drive losses and is based on sea level conditions.  
 Do not operate in black regions. All airflow in rated at lowest Voltage if unit is dual Voltage rated, i.e. 208V for 208-230V units.

# Blower Performance Data - HKV120 - Standard Unit - No ClimaDry®

All Data is Wet Coil

Airflow (SCFM)	ESP	Airflow (cfm) at External Static Pressure (in. wg)																	
		0.00	0.10	0.20	0.30	0.40	0.50	0.60	0.70	0.80	0.90	1.00	1.10	1.20	1.30	1.40	1.50		
3000	BHP			0.54	0.59	0.64	0.69	0.74	0.84	0.89	0.94	1.04	1.09	1.14	1.19	1.24	1.34		
	Sheave/Mtr			B	B	B	B	A	A	A	A	A	A	A	A	C	C		
	RPM			491	529	563	595	626	659	689	717	745	774	801	826	851	877		
	Turns Open			5	4	3	2	6	5	4	3.5	3	2	1.5	1	6	5.5		
3100	BHP		0.54	0.59	0.64	0.69	0.74	0.84	0.89	0.94	1.04	1.09	1.14	1.19	1.24	1.34	1.44		
	Sheave/Mtr			B	B	B	B	A	A	A	A	A	A	A	C	C	C		
	RPM			469	504	542	575	607	637	670	699	726	754	783	809	834	859	884	
	Turns Open			5.5	5	3.5	2.5	6	5.5	4.5	4	3.5	2.5	2	1.5	6	6	5	
3200	BHP		0.59	0.64	0.69	0.74	0.84	0.89	0.94	1.04	1.09	1.14	1.24	1.29	1.34	1.44	1.53		
	Sheave/Mtr			B	B	B	B	A	A	A	A	A	A	A	C	C	C		
	RPM			485	520	556	588	619	649	680	708	736	765	791	817	841	868	891	
	Turns Open			5	4.5	3	2	6	5	4.5	3.5	3	2.5	1.5	1	6	5.5	5	
3300	BHP	0.59	0.64	0.69	0.74	0.84	0.89	0.94	1.04	1.09	1.14	1.24	1.29	1.34	1.44	1.49	1.54		
	Sheave/Mtr			B	B	B	B	A	A	A	A	A	A	A	C	C	C		
	RPM			464	500	537	570	601	631	662	691	718	745	774	799	824	849	875	898
	Turns Open			6	5	4	2.5	2	5.5	5	4	3.5	2.5	2	1.5	1	5.5	5	4.5
3400	BHP	0.64	0.69	0.74	0.84	0.89	0.94	1.04	1.09	1.14	1.24	1.29	1.34	1.44	1.49	1.54	1.64		
	Sheave/Mtr			B	B	B	B	A	A	A	A	A	A	C	C	C	C		
	RPM			480	515	551	583	613	642	674	701	728	754	783	808	833	857	882	905
	Turns Open			5.5	4.5	3.5	2.5	6	5.5	4.5	3.5	3	2.5	2	1	6	5.5	5	4.5
3500	BHP	0.69	0.74	0.84	0.89	0.94	1.04	1.09	1.14	1.24	1.29	1.34	1.44	1.54	1.59	1.64	1.74		
	Sheave/Mtr			B	B	B	B	A	A	A	A	A	A	C	C	C	C		
	RPM			496	530	565	596	625	654	684	711	738	766	792	816	841	867	890	913
	Turns Open			5	4	3	2	6	5	4	3.5	3	2.5	1.5	1	6	5.5	5	4
3600	BHP	0.74	0.84	0.89	0.94	1.04	1.09	1.14	1.24	1.34	1.39	1.44	1.54	1.59	1.64	1.74	1.84		
	Sheave/Mtr			B	B	B	B	A	A	A	A	A	A	C	C	C	C		
	RPM			511	544	578	608	637	668	695	722	748	776	800	825	849	874	897	920
	Turns Open			4.5	3.5	2.5	6	5.5	4.5	4	3.5	2.5	2	1	6	6	5	4.5	4
3700	BHP	0.84	0.89	0.94	1.04	1.14	1.19	1.24	1.34	1.39	1.44	1.54	1.64	1.69	1.74	1.84	1.94		
	Sheave/Mtr			B	B	B	B	A	A	A	A	A	A	C	C	C	C		
	RPM			526	561	592	621	649	679	706	732	758	785	809	833	857	882	905	927
	Turns Open			4	3	2	6	5	4.5	3.5	3	2.5	1.5	1	6	5.5	5	4.5	4
3800	BHP	0.89	0.94	1.04	1.09	1.14	1.24	1.34	1.39	1.44	1.54	1.64	1.69	1.74	1.84	1.94	2.04		
	Sheave/Mtr			B	B	B	B	A	A	A	A	A	A	C	C	C	E		
	RPM			544	575	605	633	661	691	717	742	767	794	818	842	867	890	912	934
	Turns Open			3.5	2.5	1.5	5.5	5	4	3.5	2.5	2	1.5	1	6	5.5	4.5	4	3.5
3900	BHP	0.94	1.04	1.14	1.19	1.24	1.34	1.44	1.49	1.54	1.64	1.74	1.79	1.84	1.94	2.04	2.14		
	Sheave/Mtr			B	B	B	B	A	A	A	A	A	C	C	C	E	E		
	RPM			555	589	618	646	676	702	728	753	779	803	827	850	875	898	920	941
	Turns Open			3	2	6	5	4.5	3.5	3	2.5	2	1	6	5.5	5	4.5	4	3.5
4000	BHP	1.04	1.09	1.14	1.24	1.34	1.44	1.49	1.54	1.64	1.74	1.79	1.84	1.94	2.04	2.14	2.24		
	Sheave/Mtr			B	B	B	B	A	A	A	A	A	C	C	C	E	E		
	RPM			572	601	630	657	686	712	737	762	789	812	836	859	883	905	927	948
	Turns Open			2.5	2	5.5	5	4	3.5	3	2	1.5	1	6	5.5	5	4.5	4	3.5
4100	BHP	1.14	1.19	1.24	1.34	1.44	1.49	1.54	1.64	1.74	1.84	1.89	1.94	2.04	2.14	2.24	2.34		
	Sheave/Mtr			B	A	A	A	A	A	A	A	C	C	C	E	E	E		
	RPM			589	617	645	672	700	726	751	775	801	824	847	872	894	915	937	960
	Turns Open			2	6	5	4.5	4	3	2.5	2	1	6	5.5	5	4.5	4	3.5	3
4200	BHP	1.24	1.29	1.34	1.44	1.54	1.59	1.64	1.74	1.84	2	2.04	2.09	2.14	2.24	2.34	2.44		
	Sheave/Mtr			A	A	A	A	A	A	A	A	E	E	E	E	E	E		
	RPM			605	633	660	689	714	739	763	790	813	836	858	882	904	925	946	969
	Turns Open			6	5.5	5	4	3.5	2.5	1.5	1	6	5.5	5.5	4.5	4	3.5	3	
4300	BHP	1.29	1.34	1.44	1.54	1.64	1.69	1.74	1.84	2	2.04	2.14	2.24	2.29	2.34	2.44	2.54		
	Sheave/Mtr			A	A	A	A	A	A	A	E	E	E	E	E	E	E		
	RPM			621	649	675	703	728	752	776	802	827	847	869	893	914	935	956	979
	Turns Open			6	5	4.5	3.5	3	2.5	2	1	6	6	5.5	5	4.5	4	3	2.5
4400	BHP	1.39	1.44	1.54	1.64	1.74	1.84	1.89	2	2.04	2.14	2.24	2.34	2.44	2.49	2.54	2.64		
	Sheave/Mtr			A	A	A	A	A	A	D	E	E	E	E	E	E	E		
	RPM			637	664	690	717	742	766	791	814	836	858	882	904	925	945	968	988
	Turns Open			5.5	4.5	4	3.5	2.5	2	1.5	1	6	5.5	5	4.5	4	3.5	3	2.5
4500	BHP	1.49	1.54	1.64	1.74	1.84	1.94	2.04	2.09	2.14	2.24	2.34	2.44	2.54	2.64	2.74	2.84		
	Sheave/Mtr			A	A	A	A	A	D	D	E	E	E	E	E	E	E		
	RPM			653	679	707	731	755	779	804	826	848	870	893	914	935	955	978	997
	Turns Open			5	4.5	3.5	3	2	1.5	1.5	1	6	5.5	5	4.5	4	3.5	2.5	2

A = Standard Static/Standard Motor, B = Low Static/Standard Motor, C = High Static/Standard Motor, D = Standard Static/Large Motor, E = High Static/Large Motor  
 Unit factory shipped with standard static sheave and drive at 2.5 turns open. Other speed require field selection.  
 For applications requiring higher static pressures, contact your local representative. Performance data does not include drive losses and is based on sea level conditions. Do not operate in black regions. All airflow in rated at lowest Voltage if unit is dual Voltage rated, i.e. 208V for 208-230V units.

Table Continued on Next Page

# Blower Performance Data - HKV120 - Standard Unit - No ClimaDry®

**Table Continued from Previous Page**

All Data is Wet Coil

Airflow (SCFM)	ESP	Airflow (cfm) at External Static Pressure (in. wg)															
		0.00	0.10	0.20	0.30	0.40	0.50	0.60	0.70	0.80	0.90	1.00	1.10	1.20	1.30	1.40	1.50
4600	BHP	1.59	1.64	1.74	1.84	1.94	2.04	2.14	2.24	2.34	2.39	2.44	2.54	2.64	2.74	2.84	2.94
	Sheave/Mtr	A	A	A	A	A	D	D	E	E	E	E	E	E	E	E	E
	RPM	668	694	721	745	768	791	816	838	860	883	904	925	945	967	987	1007
	Turns Open	4.5	4	3	2.5	2	1.5	1	6	5.5	5	4.5	4	3.5	3	2.5	2
4700	BHP	1.74	1.84	1.89	1.94	2.04	2.14	2.24	2.34	2.44	2.54	2.64	2.69	2.74	2.84	2.94	
	Sheave/Mtr	A	A	A	A	D	D	E	E	E	E	E	E	E	E	E	
	RPM	683	711	735	758	782	806	828	850	871	894	915	935	955	977	997	
	Turns Open	4	3.5	2.5	2	2	1	6	6	5.5	5	4.5	3.5	3.5	3	2	
4800	BHP	1.84	1.94	1.99	2.04	2.14	2.24	2.34	2.44	2.54	2.64	2.74	2.84	2.94			
	Sheave/Mtr	A	A	A	D	D	D	E	E	E	E	E	E	E			
	RPM	698	725	749	772	795	819	836	862	883	906	926	946	968			
	Turns Open	3.5	3	2.5	2	1.5	1	6	5.5	5	4.5	4	3.5	3			
4900	BHP	1.94	2.04	2.14	2.24	2.34	2.44	2.49	2.54	2.64	2.74	2.84	2.94				
	Sheave/Mtr	A	D	D	D	D	E	E	E	E	E	E	E				
	RPM	715	739	762	785	810	831	853	874	896	917	937	956				
	Turns Open	3	3	2.5	2	1	6	5.5	5.5	5	4	3.5	3				
5000	BHP	2.04	2.14	2.24	2.34	2.44	2.54	2.64	2.74	2.84	2.94						
	Sheave/Mtr	D	D	D	D	E	E	E	E	E	E						
	RPM	730	753	776	798	822	844	865	885	908	928						
	Turns Open	3	2.5	2	1.5	6	6	5.5	5	4.5	4						

A = Standard Static/Standard Motor, B = Low Static/Standard Motor, C = High Static/Standard Motor, D = Standard Static/Large Motor, E = High Static/Large Motor  
 Unit factory shipped with standard static sheave and drive at 2.5 turns open. Other speed require field selection.  
 For applications requiring higher static pressures, contact your local representative. Performance data does not include drive losses and is based on sea level conditions.  
 Do not operate in black regions. All airflow in rated at lowest Voltage if unit is dual Voltage rated, i.e. 208V for 208-230V units.

# Blower Performance Data - HKV150 - Standard Unit - No ClimaDry®

All Data is Wet Coil

Airflow (SCFM)	ESP	Airflow (cfm) at External Static Pressure (in. wg)															
		0.00	0.10	0.20	0.30	0.40	0.50	0.60	0.70	0.80	0.90	1.00	1.10	1.20	1.30	1.40	1.50
3800	BHP						1.04	1.14	1.24	1.29	1.34	1.44	1.54	1.64	1.74	1.84	1.94
	Sheave/Mtr						B	B	B	A	A	A	A	A	A	A	A
	RPM						659	688	718	746	774	802	829	855	879	905	931
	Turns Open						5.5	4.5	3.5	3	5	4.5	4	3	2.5	2	1
3900	BHP					1.04	1.14	1.19	1.24	1.34	1.44	1.54	1.64	1.74	1.84	1.94	2.03
	Sheave/Mtr					B	B	B	B	A	A	A	A	A	A	A	A
	RPM					639	669	702	729	757	785	811	838	862	887	913	938
	Turns Open					6	5	4	3	5.5	5	4	3.5	3	2	1.5	1
4000	BHP					1.14	1.19	1.24	1.34	1.44	1.54	1.64	1.69	1.74	1.84	1.94	2.04
	Sheave/Mtr					B	B	B	A	A	A	A	A	A	A	A	C
	RPM					651	683	710	739	767	794	821	845	870	895	920	945
	Turns Open					5.5	4.5	4	6	5.5	4.5	4	3.5	2.5	2	1.5	6
4100	BHP			1.09	1.14	1.24	1.34	1.44	1.54	1.64	1.69	1.74	1.84	1.94	2.04	2.14	
	Sheave/Mtr			B	B	B	B	A	A	A	A	A	A	A	A	A	C
	RPM			631	661	692	722	750	778	804	831	854	879	904	928	951	
	Turns Open			6	5.5	4.5	3.5	5.5	5	4.5	3.5	3	2.5	1.5	1	6	
4200	BHP			1.14	1.24	1.34	1.44	1.54	1.59	1.64	1.74	1.84	1.94	2.04	2.14	2.24	
	Sheave/Mtr			B	B	B	B	A	A	A	A	A	A	A	A	C	
	RPM			640	673	703	733	761	788	812	838	863	888	912	934	958	
	Turns Open			6	5	4	3	5.5	4.5	4	3.5	3	2	1.5	1	5.5	
4300	BHP			1.24	1.34	1.44	1.54	1.59	1.64	1.74	1.84	1.94	2.04	2.14	2.24	2.34	
	Sheave/Mtr			B	B	B	A	A	A	A	A	A	A	A	C	C	
	RPM			653	685	715	744	771	796	822	847	872	896	919	942	966	
	Turns Open			5.5	4.5	3.5	6	5	4.5	4	3	2.5	2	1	6	5.5	
4400	BHP		1.24	1.34	1.44	1.54	1.59	1.64	1.74	1.84	1.94	2.04	2.14	2.24	2.34	2.44	
	Sheave/Mtr		B	B	B	B	A	A	A	A	A	A	A	A	C	C	
	RPM		633	666	697	726	755	782	806	832	857	881	904	927	950	973	
	Turns Open		6	5	4	3	5.5	5	4	3.5	3	2.5	1.5	1	6	5.5	
4500	BHP		1.3	1.4	1.5	1.6	1.7	1.8	1.9	2	2.1	2.2	2.3	2.4	2.5	2.6	
	Sheave/Mtr		B	B	B	A	A	A	A	A	A	A	C	C	C		
	RPM		646	678	706	735	763	791	817	842	867	889	912	935	958	980	
	Turns Open		5.5	4.5	4	6	5.5	4.5	4	3.5	2.5	2	1.5	6	6	5	
4600	BHP		1.34	1.44	1.54	1.64	1.74	1.84	1.94	2.04	2.14	2.24	2.34	2.44	2.54	2.64	
	Sheave/Mtr		B	B	B	A	A	A	A	A	A	A	C	C	C		
	RPM		656	687	715	744	772	799	825	850	872	896	919	942	963	987	
	Turns Open		5.5	4.5	3.5	6	5	4.5	3.5	3	2.5	2	1	6	5.5	5	
4700	BHP		1.34	1.44	1.54	1.64	1.74	1.84	1.94	2.04	2.14	2.24	2.34	2.44	2.54	2.64	2.74
	Sheave/Mtr		B	B	B	B	A	A	A	A	A	A	A	C	C	C	
	RPM		637	666	697	727	755	783	809	835	858	882	905	928	951	973	994
	Turns Open		6	5	4	3	5.5	5	4	3.5	3	2	1.5	1	6	5.5	4.5
4800	BHP		1.44	1.54	1.64	1.74	1.84	1.94	2.04	2.14	2.24	2.34	2.44	2.54	2.64	2.74	2.84
	Sheave/Mtr		B	B	B	A	A	A	A	A	A	A	C	C	C	C	
	RPM		647	678	708	738	766	793	819	844	867	891	914	937	959	980	1001
	Turns Open		5.5	4.5	3.5	6	5	4.5	4	3.5	2.5	2	1.5	6	5.5	5	4.5
4900	BHP	1.44	1.54	1.64	1.74	1.84	1.94	2.04	2.14	2.24	2.34	2.44	2.54	2.64	2.74	2.84	2.94
	Sheave/Mtr	B	B	B	B	A	A	A	A	A	A	A	C	C	C	C	
	RPM	631	662	690	720	749	777	803	827	852	877	900	923	946	966	988	1009
	Turns Open	6	5	4	3.5	5.5	5	4.5	3.5	3	2.5	2	1	6	5.5	5	4.5
5000	BHP	1.54	1.64	1.74	1.84	1.94	2.04	2.14	2.24	2.34	2.44	2.54	2.64	2.74	2.84	2.94	3.04
	Sheave/Mtr	B	B	B	B	A	A	A	A	A	A	A	C	C	C	E	
	RPM	642	672	702	731	760	785	811	837	862	886	909	932	953	975	996	1017
	Turns Open	5.5	5	3.5	3	5.5	4.5	4	3.5	3	2	1.5	1	6	5	4.5	4.5
5100	BHP	1.64	1.74	1.84	1.94	2.04	2.14	2.24	2.34	2.44	2.54	2.64	2.74	2.84	2.94	3.04	3.19
	Sheave/Mtr	B	B	B	A	A	A	A	A	A	A	C	C	C	E	E	
	RPM	655	685	714	743	769	798	822	847	872	896	917	940	962	983	1005	1025
	Turns Open	5.5	4.5	3.5	6	5	4.5	4	3	2.5	2	1.5	6	5.5	5	5	4.5
5200	BHP	1.74	1.84	1.94	2.04	2.14	2.24	2.34	2.44	2.54	2.64	2.74	2.84	2.94	3.09	3.19	3.29
	Sheave/Mtr	B	B	B	A	A	A	A	A	A	A	C	C	E	E	E	
	RPM	668	697	726	752	782	806	832	857	882	903	926	949	971	992	1013	1032
	Turns Open	5	4	3	5.5	5	4	3.5	3	2	1.5	1	6	5.5	5	4.5	4
5300	BHP	1.84	1.94	2.04	2.14	2.24	2.34	2.44	2.54	2.64	2.74	2.84	3.09	3.19	3.29	3.39	
	Sheave/Mtr	B	B	A	A	A	A	A	A	A	C	C	E	E	E	E	
	RPM	680	709	737	763	790	817	842	867	889	912	935	957	979	1000	1021	1042
	Turns Open	4.5	3.5	6	5.5	4.5	4	3.5	2.5	2	1.5	6	5.5	5	4.5	4	4

A = Standard Static/Standard Motor, B = Low Static/Standard Motor, C = High Static/Standard Motor, D = Standard Static/Large Motor, E = High Static/Large Motor  
 Unit factory shipped with standard static sheave and drive at 2.5 turns open. Other speed require field selection.  
 For applications requiring higher static pressures, contact your local representative. Performance data does not include drive losses and is based on sea level conditions. Do not operate in black regions. All airflow in rated at lowest Voltage if unit is dual Voltage rated, i.e. 208V for 208-230V units.

**Table Continued on Next Page**

# Blower Performance Data - HKV150 - Standard Unit - No ClimaDry®

**Table Continued from Previous Page**

All Data is Wet Coil

Airflow (SCFM)	ESP	Airflow (cfm) at External Static Pressure (in. wg)															
		0.00	0.10	0.20	0.30	0.40	0.50	0.60	0.70	0.80	0.90	1.00	1.10	1.20	1.30	1.40	1.50
5400	BHP	1.94	2.04	2.14	2.24	2.34	2.44	2.54	2.64	2.74	2.84	2.94	3.09	3.19	3.29	3.39	3.49
	Sheave/Mtr	B	B	A	A	A	A	A	A	A	A	C	E	E	E	E	E
	RPM	691	717	745	772	799	825	850	873	897	920	943	965	986	1006	1026	1047
	Turns Open	4	3.5	5.5	5	4.5	3.5	3	2.5	1.5	1	6	6	5	4.5	4	3.5
5500	BHP	2.04	2.14	2.24	2.34	2.44	2.54	2.64	2.74	2.84	3.09	3.14	3.24	3.34	3.44	3.54	3.69
	Sheave/Mtr	B	A	A	A	A	A	A	A	A	D	E	E	E	E	E	E
	RPM	704	729	756	783	810	836	859	883	907	929	952	972	993	1014	1035	1055
	Turns Open	4	6	5.5	4.5	4	3.5	3	2	1.5	1	6	5.5	5	4.5	4	3.5
5600	BHP	2.14	2.24	2.34	2.44	2.54	2.64	2.74	2.84	3.00	3.14	3.24	3.34	3.44	3.54	3.69	3.79
	Sheave/Mtr	B	A	A	A	A	A	A	A	D	D	E	E	E	E	E	E
	RPM	714	740	767	794	818	844	868	892	916	938	959	981	1002	1023	1043	1063
	Turns Open	3.5	6	5	4.5	4	3	2.5	2	1.5	1	6	5.5	4.5	4	3.5	3
5700	BHP	2.24	2.34	2.44	2.54	2.64	2.74	2.89	3.04	3.14	3.24	3.34	3.44	3.59	3.74	3.84	3.94
	Sheave/Mtr	B	A	A	A	A	A	A	D	D	E	E	E	E	E	E	E
	RPM	726	752	779	803	829	854	878	902	925	948	970	990	1011	1031	1051	1071
	Turns Open	3	5.5	5	4	3.5	3	2	2	1	6	5.5	5	4.5	4	3.5	3
5800	BHP	2.34	2.44	2.54	2.64	2.74	2.84	3.00	3.14	3.24	3.34	3.44	3.59	3.74	3.84	3.94	4.04
	Sheave/Mtr	A	A	A	A	A	A	D	D	D	E	E	E	E	E	E	E
	RPM	738	763	788	813	839	864	888	911	934	955	977	998	1019	1039	1058	1077
	Turns Open	6	5	4.5	4	3.5	2.5	2	1.5	1	6	5.5	5	4.5	4	3.5	2.5
5900	BHP	2.44	2.54	2.64	2.74	2.89	3.04	3.14	3.24	3.34	3.49	3.64	3.74	3.84	3.94	4.09	4.19
	Sheave/Mtr	A	A	A	A	A	D	D	D	E	E	E	E	E	E	E	E
	RPM	750	775	799	824	849	874	898	921	944	964	986	1007	1027	1046	1068	1086
	Turns Open	5.5	5	4	3.5	3	2.5	2	1.5	6	5.5	5	4.5	4	3.5	3	2.5
6000	BHP	2.54	2.64	2.74	2.89	3.04	3.14	3.24	3.34	3.49	3.64	3.74	3.84	3.99	4.14	4.24	4.34
	Sheave/Mtr	A	A	A	A	D	D	D	D	E	E	E	E	E	E	E	E
	RPM	758	783	808	833	858	880	904	927	950	972	993	1014	1033	1053	1073	1092
	Turns Open	5.5	4.5	4	3.5	3	2.5	1.5	1	6	5.5	5	4.5	4	3.5	3	2.5
6100	BHP	2.64	2.74	2.89	3.04	3.14	3.24	3.34	3.49	3.64	3.74	3.84	3.99	4.14	4.24	4.34	4.49
	Sheave/Mtr	A	A	A	D	D	D	D	D	E	E	E	E	E	E	E	E
	RPM	769	794	819	843	866	890	913	936	958	980	1000	1021	1041	1061	1081	1099
	Turns Open	5	4.5	3.5	3.5	2.5	2	1.5	1	6	5.5	4.5	4	3.5	3	2.5	2
6200	BHP	2.84	2.94	3.04	3.14	3.24	3.39	3.54	3.64	3.74	3.89	4.04	4.14	4.24	4.39	4.54	4.64
	Sheave/Mtr	A	A	D	D	D	D	D	E	E	E	E	E	E	E	E	E
	RPM	781	815	830	854	878	900	923	946	968	988	1009	1030	1050	1070	1089	1107
	Turns Open	4.5	4	3.5	3	2.5	2	1	6	5.5	5	4.5	4	3.5	3	2.5	2
6300	BHP	2.94	3.04	3.14	3.29	3.44	3.54	3.64	3.79	3.94	4.04	4.14	4.29	4.44	4.54	4.69	4.84
	Sheave/Mtr	A	D	D	D	D	D	D	E	E	E	E	E	E	E	E	E
	RPM	793	817	841	863	886	910	933	955	977	997	1018	1038	1058	1078	1097	1115
	Turns Open	4.5	4	3.5	3	2	1.5	1	6	5.5	5	4.5	4	3	2.5	2	1.5

A = Standard Static/Standard Motor, B = Low Static/Standard Motor, C = High Static/Standard Motor, D = Standard Static/Large Motor, E = High Static/Large Motor  
 Unit factory shipped with standard static sheave and drive at 2.5 turns open. Other speed require field selection.  
 For applications requiring higher static pressures, contact your local representative. Performance data does not include drive losses and is based on sea level conditions.  
 Do not operate in black regions. All airflow in rated at lowest Voltage if unit is dual Voltage rated, i.e. 208V for 208-230V units.

# Blower Performance Data - HKV168 - Standard Unit - No ClimaDry®

All Data is Wet Coil

Airflow (SCFM)	ESP	Airflow (cfm) at External Static Pressure (in. wg)																
		0.00	0.10	0.20	0.30	0.40	0.50	0.60	0.70	0.80	0.90	1.00	1.10	1.20	1.30	1.40	1.50	
4200	BHP				0.58	0.68	0.74	0.82	0.88	0.98	1.08	1.18	1.28	1.38	1.48	1.58	1.68	
	Sheave/Mtr				B	B	B	B	A	A	A	A	A	A	A	A	C	
	RPM				457	499	537	577	612	647	678	710	737	764	791	815	838	
	Turns Open				6	5	3.5	2.5	6	5.5	4.5	3.5	3	2	1.5	1	3	
4400	BHP				0.63	0.68	0.78	0.88	0.98	1.08	1.18	1.28	1.38	1.48	1.58	1.68	1.8	
	Sheave/Mtr				B	B	B	B	A	A	A	A	A	A	A	C	C	
	RPM				467	507	548	584	621	653	684	716	743	772	797	821	847	
	Turns Open				5.5	4.5	3.5	2.5	6	5	4	3.5	2.5	2	1	3.5	3	
4600	BHP				0.68	0.78	0.88	0.98	1.08	1.18	1.28	1.38	1.48	1.58	1.68	1.78	1.88	
	Sheave/Mtr				B	B	B	B	A	A	A	A	A	A	A	C	C	
	RPM				476	518	555	590	627	659	692	721	751	777	803	829	853	
	Turns Open				5.5	4.5	3	2	5.5	5	4	3	2.5	1.5	1	3.5	2.5	
4800	BHP		0.68	0.78	0.88	0.98	1.08	1.18	1.28	1.38	1.48	1.58	1.68	1.78	1.88	1.98		
	Sheave/Mtr		B	B	B	B	B	A	A	A	A	A	A	C	C	C		
	RPM		446	485	527	563	600	633	665	697	726	756	783	811	835	858		
	Turns Open		6	5	4	3	1.5	5.5	4.5	4	3	2.5	1.5	4	3	2.5		
5000	BHP		0.68	0.78	0.88	0.98	1.08	1.18	1.28	1.48	1.58	1.68	1.78	1.88	1.98	2.08		
	Sheave/Mtr		B	B	B	B	B	A	A	A	A	A	A	C	C	E		
	RPM		452	495	532	567	604	636	670	700	729	759	786	813	838	864		
	Turns Open		6	5	4	2.5	1.5	5.5	4.5	3.5	3	2	1.5	4	3	2.5		
5200	BHP		0.86	0.96	1.06	1.16	1.26	1.36	1.46	1.56	1.66	1.76	1.86	2.06	2.16	2.26		
	Sheave/Mtr		B	B	B	B	A	A	A	A	A	A	A	E	E	E		
	RPM		460	500	536	570	606	638	671	701	729	759	786	814	839	865		
	Turns Open		6	4.5	3.5	2.5	6	5.5	4.5	3.5	2.5	2	1	4	3.5	2.5		
5400	BHP		0.86	0.96	1.06	1.18	1.28	1.38	1.48	1.58	1.68	1.78	1.88	2.08	2.18	2.28		
	Sheave/Mtr		B	B	B	B	A	A	A	A	A	A	A	E	E	E		
	RPM		463	504	539	576	609	641	674	703	734	762	788	816	841	867		
	Turns Open		5.5	4.5	3.5	2.5	6	5	4.5	3.5	2.5	2	1	4	3.5	2.5		
5600	BHP		0.88	0.98	1.08	1.28	1.38	1.48	1.58	1.68	1.78	1.88	2.08	2.18	2.24	2.44		
	Sheave/Mtr		B	B	B	B	A	A	A	A	A	D	E	E	E	E		
	RPM		474	510	545	581	613	647	677	706	737	764	793	818	843	869		
	Turns Open		5.5	4	3	2	6	5	4	3	2.5	1.5	1.5	4	3.5	2.5		
5800	BHP		0.88	0.98	1.08	1.18	1.28	1.48	1.58	1.68	1.78	1.88	2.08	2.18	2.28	2.38	2.48	
	Sheave/Mtr		B	B	B	B	B	A	A	A	A	D	D	E	E	E		
	RPM		440	481	517	551	586	618	651	681	710	740	767	795	821	845	872	
	Turns Open		6	5	4	3	2	5.5	4.5	4	3	2	2	1.5	3.5	3	2	
6000	BHP		0.98	1.08	1.18	1.28	1.38	1.48	1.68	1.78	1.88	2.08	2.18	2.28	2.38	2.48	2.58	
	Sheave/Mtr		B	B	B	B	B	A	A	A	A	D	D	D	E	E	E	
	RPM		455	492	526	563	595	628	658	687	718	745	774	800	826	852	876	
	Turns Open		6	5	3.5	2.5	1.5	5.5	4.5	3.5	3	2.5	2	1.5	3.5	3	2	
6200	BHP		1.06	1.18	1.28	1.38	1.48	1.68	1.78	1.88	1.98	2.08	2.28	2.38	2.48	2.68	2.78	
	Sheave/Mtr		B	B	B	B	B	A	A	A	A	D	D	D	E	E	E	
	RPM		459	499	533	569	600	633	663	691	722	749	777	803	828	854	878	
	Turns Open		5.5	4.5	3.5	2.5	1.5	5.5	4	3.5	2.5	2	1	3.5	3	2		
6400	BHP		0.98	1.08	1.28	1.38	1.48	1.68	1.78	1.88	1.98	2.08	2.28	2.38	2.48	2.68	2.78	2.88
	Sheave/Mtr		B	B	B	B	B	A	A	A	D	D	D	D	E	E	E	
	RPM		441	478	513	549	581	614	644	672	703	730	759	785	810	837	861	887
	Turns Open		6	5.5	4	3	2	6	5	4	3.5	3	2.5	1.5	1	3	2.5	2
6600	BHP		1.08	1.28	1.38	1.48	1.66	1.78	1.88	1.98	2.08	2.28	2.46	2.58	2.68	2.88	2.98	
	Sheave/Mtr		B	B	B	B	B	A	A	A	D	D	D	E	E	E	E	
	RPM		456	495	529	561	595	625	656	685	712	741	767	795	820	844	870	
	Turns Open		6	5	3.5	2.5	2	5.5	4.5	4	3.5	3	2	1.5	3.5	3	2.5	
6800	BHP		1.26	1.38	1.48	1.58	1.68	1.88	1.98	2.08	2.28	2.38	2.48	2.68	2.88	2.98		
	Sheave/Mtr		B	B	B	B	A	A	A	D	D	D	D	E	E	E	E	
	RPM		471	506	539	574	604	633	664	692	721	747	773	800	825	851		
	Turns Open		5.5	4.5	3.5	2.5	6	5.5	4.5	4	3	2.5	2	1	3.5	2.5		
7000	BHP		1.28	1.48	1.58	1.68	1.88	1.98	2.08	2.28	2.46	2.58	2.68	2.88	2.98			
	Sheave/Mtr		B	B	B	B	A	A	D	D	D	D	D	E	E	E	E	
	RPM		486	520	555	586	615	647	674	704	730	756	784	808	835			
	Turns Open		5	4	3	2	6	5	4.5	3.5	3	2.5	1.5	1	3			

A = Standard Static/Standard Motor, B = Low Static/Standard Motor, C = High Static/Standard Motor, D = Standard Static/Large Motor, E = High Static/Large Motor  
 Unit factory shipped with standard static sheave and drive at 2.5 turns open. Other speed require field selection.  
 For applications requiring higher static pressures, contact your local representative. Performance data does not include drive losses and is based on sea level conditions.  
 Do not operate in black regions. All airflow in rated at lowest Voltage if unit is dual Voltage rated, i.e. 208V for 208-230V units.

# Blower Performance Data - HKV192 - Standard Unit - No ClimaDry®

All Data is Wet Coil

Airflow (SCFM)	ESP	Airflow (cfm) at External Static Pressure (in. wg)																	
		0.00	0.10	0.20	0.30	0.40	0.50	0.60	0.70	0.80	0.90	1.00	1.10	1.20	1.30	1.40	1.50		
4800	BHP			0.68	0.78	0.88	0.98	1.08	1.18	1.28	1.38	1.48	1.58	1.68	1.78	1.88	1.98		
	Sheave/Mtr			B	B	B	B	B	A	A	A	A	A	A	C	C	C		
	RPM			446	485	527	563	600	633	665	697	726	756	783	811	835	858		
	Turns Open			6	5	4	3	1.5	5.5	4.5	4	3	2.5	1.5	3.5	3	2.5		
5000	BHP			0.68	0.78	0.88	0.98	1.08	1.18	1.28	1.48	1.58	1.68	1.78	1.88	1.98	2.08		
	Sheave/Mtr			B	B	B	B	B	A	A	A	A	A	A	C	C	C		
	RPM			452	495	532	567	604	636	670	700	729	759	786	813	838	864		
	Turns Open			6	5	4	2.5	1.5	5.5	4.5	3.5	3	2.5	1.5	3.5	3	2.5		
5200	BHP			0.86	0.96	1.06	1.16	1.26	1.36	1.46	1.56	1.66	1.76	1.86	2.06	2.16	2.26		
	Sheave/Mtr			B	B	B	B	B	A	A	A	A	A	A	C	C	C		
	RPM			460	500	536	570	606	638	671	701	729	759	786	814	839	865		
	Turns Open			6	5	3.5	2.5	1.5	5	4.5	3.5	3	2.5	1	4	3	2.5		
5400	BHP			0.86	0.96	1.06	1.18	1.28	1.38	1.48	1.58	1.68	1.78	1.88	2.08	2.18	2.28		
	Sheave/Mtr			B	B	B	B	A	A	A	A	A	A	A	C	C	C		
	RPM			463	504	539	576	609	641	674	703	734	762	788	816	841	867		
	Turns Open			5.5	4.5	3.5	2.5	6	5	4	3.5	2.5	2	1	4	3	2.5		
5600	BHP			0.88	0.98	1.08	1.28	1.38	1.48	1.58	1.68	1.78	1.88	2.08	2.18	2.24	2.44		
	Sheave/Mtr			B	B	B	B	A	A	A	A	A	A	A	C	C	C		
	RPM			474	510	545	581	613	647	677	706	737	764	793	818	843	869		
	Turns Open			5.5	4.5	3	2	6	5	4	3.5	2.5	2	1.5	4	3	2.5		
5800	BHP		0.88	0.98	1.08	1.18	1.28	1.48	1.58	1.68	1.78	1.88	2.08	2.18	2.28	2.38	2.48		
	Sheave/Mtr			B	B	B	B	A	A	A	A	A	A	A	C	C	C		
	RPM			440	481	517	551	586	618	651	681	710	740	767	795	821	845	872	
	Turns Open			6	5	4	3	2	6	4.5	4	3	2.5	2	1.5	3.5	3	2.5	
6000	BHP		0.98	1.08	1.18	1.28	1.38	1.48	1.68	1.78	1.88	2.08	2.18	2.28	2.38	2.48	2.58		
	Sheave/Mtr			B	B	B	B	A	A	A	A	A	A	A	C	C	C		
	RPM			455	492	526	563	595	628	658	687	718	745	774	800	826	852	876	
	Turns Open			6	5	4	2.5	1.5	5.5	4.5	3.5	3	2.5	2	1.5	3.5	3	2	
6200	BHP		1.06	1.18	1.28	1.38	1.48	1.68	1.78	1.88	1.98	2.08	2.28	2.38	2.48	2.68	2.78		
	Sheave/Mtr			B	B	B	B	A	A	A	A	A	A	A	C	C	C		
	RPM			459	499	533	569	600	633	663	691	722	749	777	803	828	854	878	
	Turns Open			6	4.5	3.5	2.5	1.5	5.5	4.5	3.5	3	2	1.5	1	3.5	3	2	
6400	BHP		0.98	1.08	1.28	1.38	1.48	1.68	1.78	1.88	1.98	2.08	2.28	2.38	2.48	2.68	2.88		
	Sheave/Mtr			B	B	B	B	A	A	A	A	A	A	A	C	C	C		
	RPM			441	478	513	549	581	614	644	672	703	730	759	785	810	837	861	887
	Turns Open			6	5	4.5	3	2	6	5	4	3.5	2.5	2	1.5	1	3.5	2.5	2
6600	BHP		1.08	1.28	1.38	1.48	1.66	1.78	1.88	1.98	2.08	2.28	2.46	2.58	2.68	2.88	2.98	3.08	
	Sheave/Mtr			B	B	B	B	A	A	A	A	A	A	A	C	C	C	E	
	RPM			456	495	529	561	595	625	656	685	712	741	767	795	820	844	870	893
	Turns Open			6	5	4	3	2	6	4.5	4	3.5	2.5	2	1.5	3.5	3	2.5	2
6800	BHP		1.26	1.38	1.48	1.58	1.68	1.88	1.98	2.08	2.28	2.38	2.48	2.68	2.88	2.98	3.08	3.28	
	Sheave/Mtr			B	B	B	B	A	A	A	A	A	A	A	C	C	E	E	
	RPM			471	506	539	574	604	633	664	692	721	747	773	800	825	851	875	898
	Turns Open			5.5	4.5	3.5	2.5	6	5.5	4.5	4	3	2.5	2	1.5	3.5	3	2	1.5
7000	BHP		1.28	1.48	1.58	1.68	1.88	1.98	2.08	2.28	2.46	2.58	2.68	2.88	2.98	3.08	3.28	3.48	
	Sheave/Mtr			B	B	B	B	A	A	A	A	A	A	A	C	C	E	E	
	RPM			486	520	555	586	615	647	674	704	730	756	784	808	835	858	883	906
	Turns Open			5	4	3	2	6	5	4.5	3.5	3	2	1.5	3.5	3	2.5	2	1.5
7200	BHP		1.48	1.58	1.68	1.88	1.98	2.08	2.28	2.38	2.48	2.68	2.88	2.98	3.08	3.28	3.48	3.66	
	Sheave/Mtr			B	B	B	B	A	A	A	A	A	A	A	C	E	E	E	
	RPM			495	528	562	593	624	652	680	708	734	762	787	812	838	861	886	909
	Turns Open			4.5	4	2.5	1.5	6	5	4	3.5	3	2	1.5	4	3	2.5	2	1.5
7400	BHP		1.58	1.68	1.86	1.98	2.08	2.28	2.38	2.48	2.68	2.88	2.98	3.08	3.28	3.48	3.58	3.68	
	Sheave/Mtr			B	B	B	A	A	A	A	A	A	A	E	E	E	E	E	
	RPM			506	541	572	605	633	661	690	716	744	769	793	820	843	868	891	913
	Turns Open			4.5	3.5	2.5	6	5.5	4.5	4	3	2.5	2	1.5	4	3	2.5	1.5	1
7600	BHP		1.68	1.78	1.88	2.08	2.26	2.38	2.48	2.68	2.86	2.98	3.08	3.28	3.46	3.58	3.68	3.88	
	Sheave/Mtr			B	B	B	A	A	A	A	A	A	D	E	E	E	E	E	
	RPM			515	549	580	611	640	667	696	721	749	773	798	823	847	872	894	918
	Turns Open			4	3	2	6	5.5	4.5	3.5	3	2.5	2	1	3.5	3	2	1.5	1
7800	BHP		1.78	1.88	2.08	2.18	2.28	2.48	2.68	2.78	2.88	3.08	3.28	3.38	3.48	3.68	3.88	4.08	
	Sheave/Mtr			B	B	B	A	A	A	A	A	D	D	E	E	E	E	E	
	RPM			525	556	586	617	645	674	701	726	753	778	804	827	850	875	897	921
	Turns Open			4	2.5	2	5.5	5	4	3.5	3	2.5	1.5	1	3.5	2.5	2	1.5	1
8000	BHP		1.88	2.08	2.18	2.28	2.48	2.68	2.88	2.98	3.08	3.28	3.48	3.58	3.68	3.88	4.08	4.28	
	Sheave/Mtr			B	B	B	A	A	A	A	D	D	E	E	E	E	E	E	
	RPM			539	569	601	629	659	685	711	738	763	789	812	835	860	882	906	927
	Turns Open			3	2.5	1.5	5.5	4.5	4	3	2.5	2	1.5	4	3	2.5	2	1.5	1

A = Standard Static/Standard Motor, B = Low Static/Standard Motor, C = High Static/Standard Motor, D = Standard Static/Large Motor, E = High Static/Large Motor  
 Unit factory shipped with standard static sheave and drive at 2.5 turns open. Other speed require field selection.  
 For applications requiring higher static pressures, contact your local representative. Performance data does not include drive losses and is based on sea level conditions.  
 Do not operate in black regions. All airflow in rated at lowest Voltage if unit is dual Voltage rated, i.e. 208V for 208-230V units.

# Blower Performance Data - HKV240 - Standard Unit - No ClimaDry®

All Data is Wet Coil

Airflow (SCFM)	ESP	Airflow (cfm) at External Static Pressure (in. wg)															
		0.00	0.10	0.20	0.30	0.40	0.50	0.60	0.70	0.80	0.90	1.00	1.10	1.20	1.30	1.40	1.50
6000	BHP				1.18	1.28	1.38	1.48	1.68	1.78	1.88	2.08	2.18	2.28	2.38	2.48	2.68
	Sheave/Mtr				B	B	B	B	A	A	A	A	A	A	A	A	C
	RPM				529	563	595	626	659	689	717	745	774	801	826	851	877
	Turns Open				6	5	4	3	6	5	4.5	4	3.5	2.5	2	1	5.5
6200	BHP				1.28	1.38	1.48	1.68	1.78	1.88	2.08	2.18	2.28	2.38	2.48	2.68	2.88
	Sheave/Mtr				B	B	B	B	A	A	A	A	A	A	A	A	C
	RPM				542	575	607	637	670	699	726	754	783	809	834	859	884
	Turns Open				5.5	4.5	3.5	3	5.5	5	4.5	3.5	3	2.5	1.5	1	5
6400	BHP			1.28	1.38	1.48	1.68	1.78	1.88	2.08	2.18	2.28	2.48	2.58	2.68	2.88	3.06
	Sheave/Mtr				B	B	B	B	A	A	A	A	A	A	A	C	C
	RPM				520	556	588	619	649	680	708	736	765	791	817	841	868
	Turns Open				6	5	4	3.5	6	5.5	4.5	4	3.5	2.5	2	1.5	5.5
6600	BHP				1.38	1.48	1.68	1.78	1.88	2.08	2.18	2.28	2.48	2.58	2.68	2.88	2.98
	Sheave/Mtr				B	B	B	B	A	A	A	A	A	A	A	C	C
	RPM				537	570	601	631	662	691	718	745	774	799	824	849	875
	Turns Open				5.5	4.5	4	3	5.5	5	4.5	3.5	3	2.5	2	1	5
6800	BHP				1.48	1.68	1.78	1.88	2.08	2.18	2.28	2.48	2.58	2.68	2.88	2.98	3.28
	Sheave/Mtr				B	B	B	B	A	A	A	A	A	A	A	C	C
	RPM				551	583	613	642	674	701	728	754	783	808	833	857	882
	Turns Open				5.5	4.5	3.5	2.5	5.5	5	4	3.5	3	2	1.5	1	5
7000	BHP		1.48	1.68	1.78	1.88	2.08	2.18	2.28	2.48	2.58	2.68	2.88	3.08	3.18	3.28	3.48
	Sheave/Mtr				B	B	B	B	A	A	A	A	A	A	A	C	C
	RPM				530	565	596	625	654	684	711	738	766	792	816	841	867
	Turns Open				6	5	4	3	6	5	4.5	4	3	2.5	2	1.5	5.5
7200	BHP		1.68	1.78	1.88	2.08	2.18	2.28	2.48	2.68	2.78	2.88	3.08	3.18	3.28	3.48	3.68
	Sheave/Mtr				B	B	B	B	A	A	A	A	A	A	A	C	C
	RPM				544	578	608	637	668	695	722	748	776	800	825	849	874
	Turns Open				5.5	4.5	3.5	2.5	5.5	5	4.5	3.5	3	2.5	1.5	1	5
7400	BHP		1.78	1.88	2.08	2.28	2.38	2.48	2.68	2.78	2.88	3.08	3.28	3.38	3.48	3.68	3.88
	Sheave/Mtr				B	B	B	B	A	A	A	A	A	A	C	C	C
	RPM				561	592	621	649	679	706	732	758	785	809	833	857	882
	Turns Open				5	4	3	2.5	5.5	4.5	4	3.5	2.5	2	1.5	5.5	5
7600	BHP		1.78	1.88	2.08	2.18	2.28	2.48	2.68	2.78	2.88	3.08	3.28	3.38	3.48	3.68	3.88
	Sheave/Mtr				B	B	B	B	A	A	A	A	A	A	C	C	C
	RPM				544	575	605	633	661	691	717	742	767	794	818	842	867
	Turns Open				5.5	4.5	3.5	3	5.5	5	4.5	4	3	2.5	2	1	5.5
7800	BHP		1.88	2.08	2.28	2.38	2.48	2.68	2.88	2.98	3.08	3.28	3.48	3.58	3.68	3.88	4.08
	Sheave/Mtr				B	B	B	A	A	A	A	A	A	A	C	C	C
	RPM				555	589	618	646	676	702	728	753	779	803	827	850	875
	Turns Open				5	4	3	6	5.5	4.5	4	3.5	3	2	1.5	1	5
8000	BHP		2.08	2.18	2.28	2.48	2.68	2.88	2.98	3.08	3.28	3.48	3.58	3.68	3.88	4.08	4.28
	Sheave/Mtr				B	B	B	A	A	A	A	A	A	C	C	C	C
	RPM				572	601	630	657	686	712	737	762	789	812	836	859	883
	Turns Open				4.5	3.5	3	5.5	5	4.5	4	3	2.5	2	1.5	5.5	5
8200	BHP		2.28	2.38	2.48	2.68	2.88	2.98	3.08	3.28	3.48	3.68	3.78	3.88	4.08	4.28	4.48
	Sheave/Mtr				B	B	B	A	A	A	A	A	A	C	C	C	C
	RPM				589	617	645	672	700	726	751	775	801	824	847	872	894
	Turns Open				4	3.5	2.5	5.5	4.5	4	3.5	3	2.5	1.5	1	5.5	5
8400	BHP		2.48	2.58	2.68	2.88	3.08	3.18	3.28	3.48	3.68	4	4.08	4.18	4.28	4.48	4.68
	Sheave/Mtr				B	B	A	A	A	A	A	A	A	C	C	C	C
	RPM				605	633	660	689	714	739	763	790	813	836	858	882	904
	Turns Open				3.5	3	5.5	5	4.5	4	3	2.5	2	1.5	1	5	4.5

A = Standard Static/Standard Motor, B = Low Static/Standard Motor, C = High Static/Standard Motor, D = Standard Static/Large Motor, E = High Static/Large Motor  
 Unit factory shipped with standard static sheave and drive at 2.5 turns open. Other speed require field selection.  
 For applications requiring higher static pressures, contact your local representative. Performance data does not include drive losses and is based on sea level conditions. Do not operate in black regions. All airflow in rated at lowest Voltage if unit is dual Voltage rated, i.e. 208V for 208-230V units.

**Table Continued on Next Page**

# Blower Performance Data - HKV240 - Standard Unit - No ClimaDry®

**Table Continued from Previous Page**

All Data is Wet Coil

Airflow (SCFM)	ESP	Airflow (cfm) at External Static Pressure (in. wg)															
		0.00	0.10	0.20	0.30	0.40	0.50	0.60	0.70	0.80	0.90	1.00	1.10	1.20	1.30	1.40	1.50
8600	BHP	2.58	2.68	2.88	3.08	3.28	3.38	3.48	3.68	4	4.08	4.28	4.48	4.58	4.68	4.88	5.08
	Sheave/Mtr	B	A	A	A	A	A	A	A	A	A	C	C	C	C	C	E
	RPM	621	649	675	703	728	752	776	802	827	847	869	893	914	935	956	979
	Turns Open	3	6	5.5	4.5	4	3.5	3	2.5	2	1	5.5	5	4.5	4	3.5	2.5
8800	BHP	2.78	2.88	3.08	3.28	3.48	3.68	3.78	4	4.08	4.28	4.48	4.68	4.88	4.98	5.08	5.28
	Sheave/Mtr	B	A	A	A	A	A	A	A	A	C	C	C	C	E	E	
	RPM	637	664	690	717	742	766	791	814	836	858	882	904	925	945	968	988
	Turns Open	2.5	5.5	5	4.5	3.5	3	2.5	2	1.5	1	5	4.5	4	3.5	3	2.5
9000	BHP	2.98	3.08	3.28	3.48	3.68	3.88	4.08	4.18	4.28	4.48	4.68	4.88	5.08	5.28	5.48	5.68
	Sheave/Mtr	A	A	A	A	A	A	A	A	A	C	C	C	E	E	E	E
	RPM	653	679	707	731	755	779	804	826	848	870	893	914	935	955	978	997
	Turns Open	6	5	4.5	4	3.5	3	2.5	2	1.5	5.5	5	4.5	4	3.5	2.5	2
9200	BHP	3.18	3.28	3.48	3.68	3.88	4.08	4.28	4.48	4.68	4.78	4.88	5.08	5.28	5.48	5.68	5.88
	Sheave/Mtr	A	A	A	A	A	A	A	A	A	C	C	E	E	E	E	E
	RPM	668	694	721	745	768	791	816	838	860	883	904	925	945	967	987	1007
	Turns Open	5.5	5	4	3.5	3	2.5	2	1.5	1	5	4.5	4	3.5	3	2.5	2
9400	BHP	3.48	3.68	3.78	3.88	4.08	4.28	4.48	4.68	4.88	5.08	5.28	5.38	5.48	5.68	5.88	6.08
	Sheave/Mtr	A	A	A	A	A	A	A	A	C	E	E	E	E	E	E	E
	RPM	683	711	735	758	782	806	828	850	871	894	915	935	955	977	997	1016
	Turns Open	5	4.5	4	3.5	3	2.5	2	1	5.5	5	4.5	4	3.5	3	2	2
9600	BHP	3.68	3.88	3.98	4.08	4.28	4.48	4.68	4.88	5.08	5.28	5.48	5.68	5.88	6.08	6.28	6.48
	Sheave/Mtr	A	A	A	A	A	A	A	A	E	E	E	E	E	E	E	E
	RPM	698	725	749	772	795	819	836	862	883	906	926	946	968	987	1007	1025
	Turns Open	4.5	4	3.5	3	2.5	2	1.5	1	5	4.5	4	3.5	3	2.5	2	1.5
9800	BHP	3.88	4.08	4.28	4.48	4.68	4.88	4.98	5.08	5.28	5.48	5.68	5.88	6.08	6.28	6.48	6.68
	Sheave/Mtr	A	A	A	A	A	A	A	E	E	E	E	E	E	E	E	E
	RPM	715	739	762	785	810	831	853	874	896	917	937	956	978	997	1016	1035
	Turns Open	4.5	4	3.5	3	2.5	1.5	1	5.5	4.5	4.5	3.5	3	3	2.5	2	1.5
10000	BHP	4.08	4.28	4.48	4.68	4.88	5.08	5.28	5.48	5.68	5.88	6.08	6.28	6.48	6.68	6.78	6.88
	Sheave/Mtr	A	A	A	A	A	E	E	E	E	E	E	E	E	E	E	E
	RPM	730	753	776	798	822	844	865	885	908	928	948	967	988	1007	1026	1044
	Turns Open	4	3.5	3	2.5	2	6	5.5	5	4.5	4	3.5	3	2.5	2	1.5	1

A = Standard Static/Standard Motor, B = Low Static/Standard Motor, C = High Static/Standard Motor, D = Standard Static/Large Motor, E = High Static/Large Motor  
 Unit factory shipped with standard static sheave and drive at 2.5 turns open. Other speed require field selection.  
 For applications requiring higher static pressures, contact your local representative. Performance data does not include drive losses and is based on sea level conditions. Do not operate in black regions. All airflow in rated at lowest Voltage if unit is dual Voltage rated, i.e. 208V for 208-230V units.

# Blower Performance Data - HKV300 - Standard Unit - No ClimaDry®

All Data is Wet Coil

Airflow (SCFM)	ESP	Airflow (cfm) at External Static Pressure (in. wg)																	
		0.00	0.10	0.20	0.30	0.40	0.50	0.60	0.70	0.80	0.90	1.00	1.10	1.20	1.30	1.40	1.50		
7600	BHP						2.08	2.28	2.48	2.58	2.68	2.88	3.08	3.28	3.48	3.68	3.88		
	Sheave/Mtr						B	B	B	B	A	A	A	A	A	A	A		
	RPM						659	669	702	729	757	785	811	838	862	887	913		
	Turns Open						5.5	4.5	3.5	3	6	5	4.5	3.5	3	2	1.5		
7800	BHP					2.08	2.28	2.38	2.48	2.68	2.88	3.08	3.28	3.48	3.68	3.88	4.06		
	Sheave/Mtr					B	B	B	B	B	A	A	A	A	A	A	A		
	RPM					639	669	702	729	757	785	811	838	862	887	913	938		
	Turns Open					5.5	5	4	3	2.5	5.5	5	4	3.5	2.5	2	1		
8000	BHP					2.28	2.38	2.48	2.68	2.88	3.08	3.28	3.38	3.48	3.68	3.88	4.08		
	Sheave/Mtr					B	B	B	B	B	A	A	A	A	A	A	A		
	RPM					651	683	710	739	767	794	821	845	870	895	920	945		
	Turns Open					5.5	4.5	3.5	3	2	5.5	4.5	4	3	2.5	1.5	1		
8200	BHP			2.18	2.28	2.48	2.68	2.88	3.08	3.28	3.38	3.48	3.68	3.88	4.08	4.28			
	Sheave/Mtr			B	B	B	B	B	A	A	A	A	A	A	A	C			
	RPM			631	661	692	722	750	778	804	831	854	879	904	928	951			
	Turns Open			6	5	4	3.5	2.5	6	5	4.5	3.5	3	2	1.5	3.5			
8400	BHP			2.28	2.48	2.68	2.88	3.08	3.18	3.28	3.48	3.68	3.88	4.08	4.28	4.48			
	Sheave/Mtr			B	B	B	B	B	A	A	A	A	A	A	A	C			
	RPM			640	673	703	733	761	788	812	838	863	888	912	934	958			
	Turns Open			5.5	5	4	3	2	5.5	5	4	3.5	2.5	2	1	3			
8600	BHP			2.48	2.68	2.88	3.08	3.18	3.28	3.48	3.68	3.88	4.08	4.28	4.48	4.68			
	Sheave/Mtr			B	B	B	B	A	A	A	A	A	A	A	A	C			
	RPM			653	685	715	744	771	796	822	847	872	896	919	942	966			
	Turns Open			5.5	4.5	3.5	2.5	6	5.5	4.5	4	3	2.5	1.5	1	3			
8800	BHP			2.48	2.68	2.88	3.08	3.18	3.28	3.48	3.68	3.88	4.08	4.28	4.48	4.68	4.88		
	Sheave/Mtr			B	B	B	B	B	A	A	A	A	A	A	A	C	C		
	RPM			633	666	697	726	755	782	806	832	857	881	904	927	950	973		
	Turns Open			6	5	4	3	2.5	5.5	5	4	3.5	3	2	1.5	3.5	2.5		
9000	BHP			2.6	2.8	3	3.2	3.4	3.6	3.8	4	4.2	4.4	4.6	4.8	5	5.2		
	Sheave/Mtr			B	B	B	B	B	A	A	A	A	A	A	A	C	E		
	RPM			646	678	706	735	763	791	817	842	867	889	912	935	958	980		
	Turns Open			5.5	4.5	3.5	3	2	5.5	4.5	4	3	2.5	2	1	3	2.5		
9200	BHP			2.68	2.88	3.08	3.28	3.48	3.68	3.88	4.08	4.28	4.48	4.68	4.88	5.08	5.28		
	Sheave/Mtr			B	B	B	B	A	A	A	A	A	A	A	A	E	E		
	RPM			656	687	715	744	772	799	825	850	872	896	919	942	963	987		
	Turns Open			5.5	4.5	3.5	2.5	6	5	4.5	3.5	3	2.5	1.5	1	3	2.5		
9400	BHP			2.68	2.88	3.08	3.28	3.48	3.68	3.88	4.08	4.28	4.48	4.68	4.88	5.08	5.28	5.48	
	Sheave/Mtr			B	B	B	B	B	A	A	A	A	A	A	A	E	E	E	
	RPM			637	666	697	727	755	783	809	835	858	882	905	928	951	973	994	
	Turns Open			6	5	4	3	2.5	5.5	5	4	3.5	2.5	2	1.5	3.5	3	2	
9600	BHP			2.88	3.08	3.28	3.48	3.68	3.88	4.08	4.28	4.48	4.68	4.88	5.08	5.28	5.48	5.68	
	Sheave/Mtr			B	B	B	B	A	A	A	A	A	A	A	D	E	E	E	
	RPM			647	678	708	738	766	793	819	844	867	891	914	937	959	980	1001	
	Turns Open			5.5	4.5	3.5	3	6	5	4.5	4	3	2.5	2	1	3	2.5	2	
9800	BHP			2.88	3.08	3.28	3.48	3.68	3.88	4.08	4.28	4.48	4.68	4.88	5.08	5.28	5.48	5.68	5.88
	Sheave/Mtr			B	B	B	B	A	A	A	A	A	A	D	E	E	E	E	E
	RPM			631	662	690	720	749	777	803	827	852	877	900	923	946	966	988	1009
	Turns Open			6	5	4	3.5	2.5	5.5	5	4.5	3.5	2.5	2	1.5	3.5	3	2.5	2
10000	BHP			3.08	3.28	3.48	3.68	3.88	4.08	4.28	4.48	4.68	4.88	5.08	5.28	5.48	5.68	5.88	6.08
	Sheave/Mtr			B	B	B	B	A	A	A	A	A	D	D	E	E	E	E	E
	RPM			642	672	702	731	760	785	811	837	862	886	909	932	953	975	996	1017
	Turns Open			5.5	4.5	4	3	2	5.5	4.5	4	3.5	2.5	2	1	3	2.5	2	2
10200	BHP			3.28	3.48	3.68	3.88	4.08	4.28	4.48	4.68	4.88	5.08	5.28	5.48	5.68	5.88	6.08	6.38
	Sheave/Mtr			B	B	B	B	A	A	A	A	A	D	D	D	E	E	E	E
	RPM			655	685	714	743	769	798	822	847	872	896	917	940	962	983	1005	1025
	Turns Open			5	4.5	3.5	2.5	6	5	4.5	3.5	3	2.5	1.5	1	3	2.5	2	1.5
10400	BHP			3.48	3.68	3.88	4.08	4.28	4.48	4.68	4.88	5.08	5.28	5.48	5.68	5.88	6.18	6.38	6.58
	Sheave/Mtr			B	B	B	B	A	A	A	A	D	D	E	E	E	E	E	E
	RPM			668	697	726	752	782	806	832	857	882	903	926	949	971	992	1013	1032
	Turns Open			5	4	3	2.5	5.5	5	4	3.5	2.5	2	1.5	3.5	3	2.5	2	1.5
10600	BHP			3.68	3.88	4.08	4.28	4.48	4.68	4.88	5.08	5.28	5.48	5.68	5.88	6.18	6.38	6.58	6.78
	Sheave/Mtr			B	B	B	B	A	A	A	D	D	D	E	E	E	E	E	E
	RPM			680	709	737	763	790	817	842	867	889	912	935	957	979	1000	1021	1042
	Turns Open			4.5	3.5	3	2	5.5	4.5	4	3	2.5	2	1	3	2.5	2	1.5	1

A = Standard Static/Standard Motor, B = Low Static/Standard Motor, C = High Static/Standard Motor, D = Standard Static/Large Motor, E = High Static/Large Motor  
 Unit factory shipped with standard static sheave and drive at 2.5 turns open. Other speed require field selection.  
 For applications requiring higher static pressures, contact your local representative. Performance data does not include drive losses and is based on sea level conditions. Do not operate in black regions. All airflow in rated at lowest Voltage if unit is dual Voltage rated, i.e. 208V for 208-230V units.

Table Continued on Next Page

# Blower Performance Data - HKV300 - Standard Unit - No ClimaDry®

**Table Continued from Previous Page**

All Data is Wet Coil

Airflow (SCFM)	ESP	Airflow (cfm) at External Static Pressure (in. wg)															
		0.00	0.10	0.20	0.30	0.40	0.50	0.60	0.70	0.80	0.90	1.00	1.10	1.20	1.30	1.40	1.50
10800	BHP	3.88	4.08	4.28	4.48	4.68	4.88	5.08	5.28	5.48	5.68	5.88	6.18	6.38	6.58	6.78	6.98
	Sheave/Mtr	B	B	B	A	A	A	D	D	D	D	E	E	E	E	E	E
	RPM	691	717	745	772	799	825	850	873	897	920	943	965	986	1006	1026	1047
	Turns Open	4.5	3.5	2.5	6	5	4.5	3.5	3	2	1.5	3.5	3	2.5	2	1.5	1
11000	BHP	4.08	4.28	4.48	4.68	4.88	5.08	5.28	5.48	5.68	6.18	6.28	6.48	6.68	6.88	7.08	7.38
	Sheave/Mtr	B	B	B	A	A	D	D	D	D	E	E	E	E	E	E	E
	RPM	704	729	756	783	810	836	859	883	907	929	952	972	993	1014	1035	1055
	Turns Open	3.5	3	2	5.5	5	4	3	2.5	2	1.5	3.5	3	2.5	2	1	0.5
11200	BHP	4.28	4.48	4.68	4.88	5.08	5.28	5.48	5.68	6.00	6.28	6.48	6.68	6.88	7.08	7.38	
	Sheave/Mtr	B	B	A	A	D	D	D	D	D	E	E	E	E	E	E	
	RPM	714	740	767	794	818	844	868	892	916	938	959	981	1002	1023	1043	
	Turns Open	3.5	2.5	6	5.5	4.5	3.5	3	2.5	1.5	1	3	2.5	2	1.5	1	
11400	BHP	4.48	4.68	4.88	5.08	5.28	5.48	5.78	6.08	6.28	6.48	6.68	6.88	7.18	7.48		
	Sheave/Mtr	B	B	A	D	D	D	D	D	D	E	E	E	E	E		
	RPM	726	752	779	803	829	854	878	902	925	948	970	990	1011	1031		
	Turns Open	3	2	5.5	5	4.5	3.5	3	2	1.5	1	3	2.5	2	1.5		
11600	BHP	4.68	4.88	5.08	5.28	5.48	5.68	6.00	6.28	6.48	6.68	6.88	7.18	7.48			
	Sheave/Mtr	B	A	D	D	D	D	D	D	E	E	E	E	E			
	RPM	738	763	788	813	839	864	888	911	934	955	977	998	1019			
	Turns Open	2.5	6	5.5	4.5	4	3	2.5	2	1	3.5	2.5	2	1.5			
11800	BHP	4.88	5.08	5.28	5.48	5.78	6.08	6.28	6.48	6.68	6.98	7.28	7.48				
	Sheave/Mtr	B	D	D	D	D	D	D	D	D	E	E	E				
	RPM	750	775	799	824	849	874	898	921	944	964	986	1007				
	Turns Open	2	5.5	5	4	3.5	3	2.5	2	1	3	2.5	2				
12000	BHP	5.08	5.28	5.48	5.78	6.08	6.28	6.48	6.68	6.98	7.28	7.48					
	Sheave/Mtr	D	D	D	D	D	D	D	D	E	E	E					
	RPM	758	783	808	833	858	880	904	927	950	972	993					
	Turns Open	6	5.5	4.5	4	3.5	2.5	2	1.5	3.5	3	2.5					
12200	BHP	5.28	5.48	5.78	6.08	6.28	6.48	6.68	6.98	7.28	7.48						
	Sheave/Mtr	D	D	D	D	D	D	D	D	E	E	E					
	RPM	769	794	819	843	866	890	913	936	958	980						
	Turns Open	6	5	4.5	4	3	2.5	2	1.5	3	2.5						
12400	BHP	5.68	5.88	6.08	6.28	6.48	6.78	7.08	7.28	7.48							
	Sheave/Mtr	D	D	D	D	D	D	D	D	E							
	RPM	781	815	830	854	878	900	923	946	968							
	Turns Open	5.5	4.5	4.5	3.5	3	2	1.5	1	3							
12600	BHP	5.88	6.08	6.28	6.58	6.88	7.08	7.28									
	Sheave/Mtr	D	D	D	D	D	D	D									
	RPM	793	817	841	863	886	910	933									
	Turns Open	5	4.5	4	3	2.5	2	1.5									

A = Standard Static/Standard Motor, B = Low Static/Standard Motor, C = High Static/Standard Motor, D = Standard Static/Large Motor, E = High Static/Large Motor  
 Unit factory shipped with standard static sheave and drive at 2.5 turns open. Other speed require field selection.  
 For applications requiring higher static pressures, contact your local representative. Performance data does not include drive losses and is based on sea level conditions.  
 Do not operate in black regions. All airflow in rated at lowest Voltage if unit is dual Voltage rated, i.e. 208V for 208-230V units.

## Blower Performance Data - Units with ClimaDry®

Coil Face Velocity FPM	HKV with ClimaDry® - Additional ESP Loss		
	HKV084, 096, 168 & 192 In. of Water	HKV120 & 240 In. of Water	HKV300 In. of Water
200	0.14	-	-
225	0.15	-	-
250	0.16	-	-
275	0.17	0.17	-
300	0.18	0.18	-
325	0.19	0.19	0.23
350	0.21	0.21	0.25
375	0.22	0.22	0.26
400	-	0.24	0.28
425	-	0.26	0.30
450	-	0.29	0.33
475	-	-	0.35
500	-	-	0.38
525	-	-	0.41
550	-	-	0.45
575	-	-	0.48

All data is for wet coil.

### Example:

Reheat coil loss can be determined from the above table. Coil velocity (FPM) = Airflow (CFM) / Face Area (sq. ft.)

1. HKV120 has a face area of 11 sq. ft. (see physical data table).
2. At 4,200 cfm, coil velocity (FPM) = 4,200 / 11 = 380 FPM
3. From above table, ESP is .22.
4. HKV120 (without ClimaDry®) A Drive at .5 ESP, 2.5 turns = 4200 CFM  
 HKV120 (with ClimaDry®) A Drive at .72 ESP, 2.5 turns = 3900 CFM  
 If drop in CFM is not acceptable, adjust turns to 1.5 for 4200 CFM.  
 Note - Sometimes drive package must be changed.

Model	084	096	120	150	168	192	240	300
Compressor Quantity	Scroll (1)				Scroll (2)			
Factory Charge HFC-410a (oz) [kg] per circuit	140 [3.97]	156 [4.42]	224 [6.35]	248 [7.03]	140 [3.97]	156 [4.42]	224 [6.35]	248 [7.03]
<b>Blower Motor</b>								
Blower Motor Quantity	1							
Standard Motor (hp) [kW]	1.0 [.75]	1.5 [1.12]	2 [1.49]	3 [2.24]	2 [1.49]	3 [2.24]	5 [3.73]	5 [3.73]
Large Motor (hp) [kW]	1.5 [1.12]	2.0 [1.49]	3 [2.24]	5 [3.73]	3 [2.24]	5 [3.73]	7.5 [5.60]	7.5 [5.60]
<b>Blower</b>								
No. of Blowers	1				2			
Blower Wheel Size D x W (in) [cm]	15 x 11 [38.1 x 38.1]			15 x 15 [38.1 x 38.1]	15 x 11 [38.1 x 38.1]			15 x 15 [38.1 x 38.1]
<b>Water Connection Size</b>								
FPT (in) [mm]	1-1/2" [38.1]			2" [50.8]			2-1/2" [63.5]	
<b>Coax Volume</b>								
Volume (US Gallons) [liters]	2.19 [8.28]	2.48 [9.37]	3.46 [13.11]	4.83 [18.29]	6.36 [24.08]	7.39 [27.98]		
<b>Condensate Connection Size</b>								
FPT (in) [mm]	1" [25.4]							
<b>Air Coil Data</b>								
Air Coil Dimensions H x W (in) [cm]	36 x 48 [91.4 x 121.9]				2 - 36 x 48 [91.4 x 121.9]			
Air Coil Total Face Area (ft <sup>2</sup> ) [m <sup>2</sup> ]	12 [1.11]				24 [2.22]			
<b>Miscellaneous Data</b>								
Filter Standard - 1" [25.4mm] Throwaway (qty) (in) [cm]	(QTY.4) 18 x 25 [45.74 x 63.5]				(QTY.8) 18 x 25 [45.74 x 63.5]			
Weight - Operating (lbs) [kg]	880 [399]	930 [422]	960 [435]	1600 [725]	1665 [755]	1695 [769]		
Weight - Packaged (lbs) [kg]	895 [406]	945 [429]	975 [442]	1630 [739]	1695 [769]	1725 [782]		

All units have grommet compressor mountings, and 1/2" & 1-3/4" electrical knockouts.  
 For ClimaDry® option, add 125 lbs [57 kg] for 084-150 and 250 lbs [114 kg] for 168-300.

Unit Maximum Water Working Pressure	
Options	Max Pressure PSIG [kPa]
Base Unit	300 [2,068]
Motorized Water Valve	300 [2,068]
Internal Secondary Pump or ClimaDry®	145 [999]

Use the lowest maximum pressure rating when multiple options are combined.

# HKV084-150 Dimensional Data

ALL CONFIGURATIONS REQUIRE SERVICE ACCESS AREA DESCRIBED IN NOTES 7, 8, 9, AND 10.

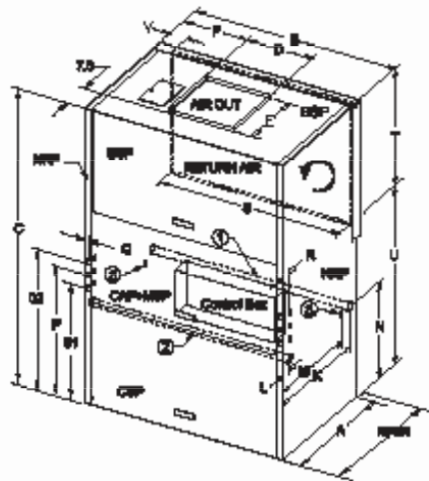

**REAR RETURN TOP DISCHARGE (RRTD)**

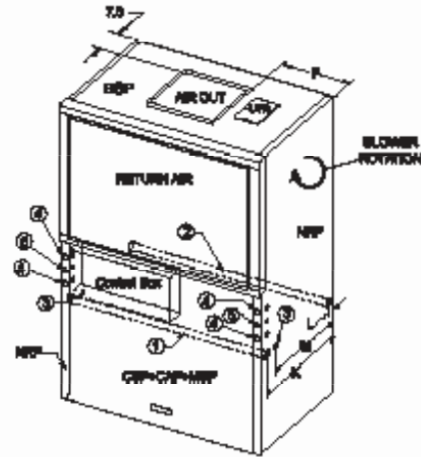

**FRONT RETURN TOP DISCHARGE (FRTD)**

LEGEND	HKV084-120	HKV150
① Water Inlet (See Note 2)	1-1/2" FPT	2" FPT
② Water Outlet (See Note 2)	1-1/2" FPT	2" FPT
③ Condensate Drain (See Note 3)	1" FPT	
④ High Voltage Access (See Note 4)	1-3/8" [3.49 CM]	
⑤ Low Voltage Access (See Note 4)	7/8" [2.2 CM]	

BSP - Blower Service Panel  
 CAP - Control Access Panel  
 CSP - Compressor Access Panel  
 MSP - Motor Service Panel  
 NRP - Non-Removable Panel  
 UPA - Upper Pulley Access

**NOTES:**

- All dimensions in inches (cm)
- Water inlet and water outlet connections are available on either side (left or right) of the unit. Installer must plug water inlet/outlet not being connected to.
- Condensate drain is available on either side (left or right) of unit. Drain hose and drain connection will be tied inside the unit. Installer will utilize the drain hose, form trap, and connect to the condensate drain hole of installer's choice.
- Electrical access is available on either side (left or right) of unit and is also available in the front on the left or right side of the unit.
- Overall Depth - Add 3.12(8 cm) for 1"(2.5 cm) or 2"(5 cm) Filter Frame; 5.12" for 4" Filter Frame and for FD, RD additional 1.06"(2.7 cm) for supply air duct flange.
- Overall cabinet height dimension does not include duct flange when in top discharge configuration.
- While access to all removable panels may not be required, installer should take care to comply with all building codes and allow adequate clearance for future field service.
- Units require 3 feet(91 cm) clearance for water connections, CAP, CSP, MSP and BSP service access.
- Side service access must be 2 feet(64 cm) on any side that connections are made. If no connections are made on a side then service access can be 6 inches(15 cm) minimum.
- Filter removal is from bottom of frame, allow 2 feet(64 cm) access for servicing.

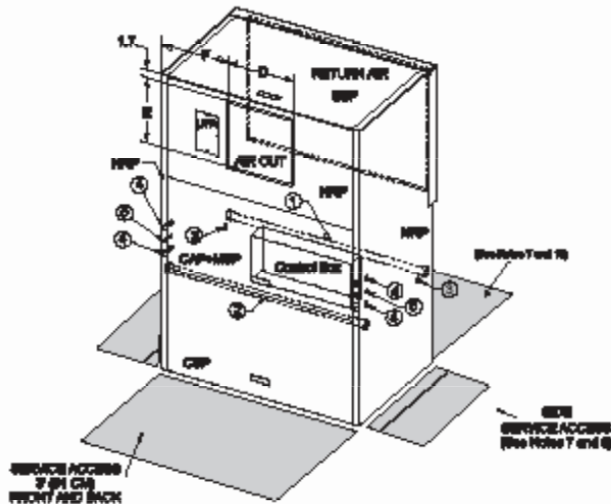

**REAR RETURN FRONT DISCHARGE (RRFD)**

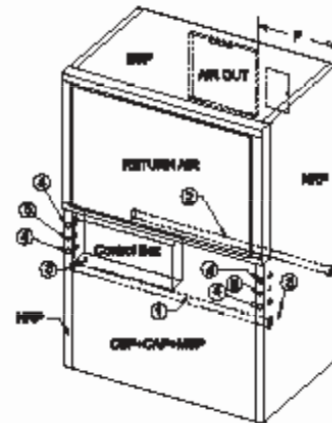

**FRONT RETURN REAR DISCHARGE (FRRD)**

Model	Overall Cabinet			Discharge Connections Duct Flange			Water Connections				Electrical Knockouts					Return Air Connections Using Return Air Opening			
	A	B	C	D	E	F	K	L	M	N	O1	O2	P	Q	R	S	T	U	V
	Depth Note 5	Width	Height Note 6	Supply Width	Supply Depth		1 Water Inlet	2 Water Outlet	3 Condensate							Return Depth	Return Height		
084-120	in. 34.0 cm. 86.4	53.1 134.9	79.0 200.7	17.5 44.5	17.6 44.6	17.8 45.1	31.0 78.7	3.0 7.6	27.0 68.6	25.6 65.1	31.0 78.7	38.0 96.4	34.6 87.7	1.0 2.5	3.0 7.6	48.0 121.9	32.4 82.2	44.6 113.3	2.7 6.9
150	in. 34.0 cm. 86.4	53.1 134.9	79.0 200.7	21.4 54.4	17.6 44.6	17.8 45.1	31.0 78.7	3.0 7.6	27.0 68.6	25.6 65.1	31.0 78.7	38.0 96.4	34.6 87.7	1.0 2.5	3.0 7.6	48.0 121.9	32.4 82.2	44.6 113.3	2.7 6.9

**ALL CONFIGURATIONS REQUIRE SERVICE ACCESS AREA DESCRIBED IN NOTES 7, 8, 9, AND 10.**

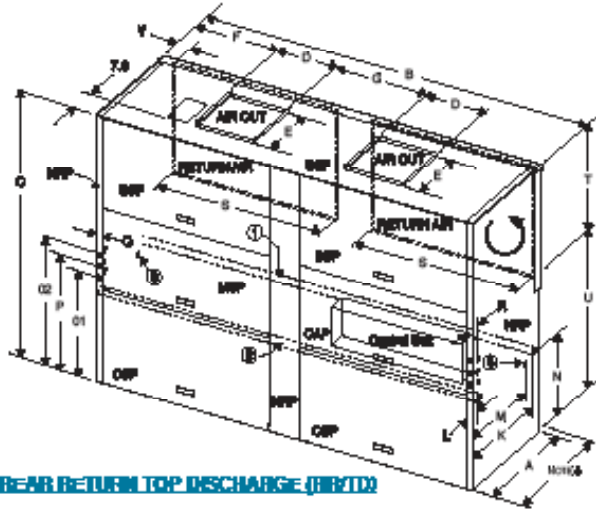

**REAR RETURN TOP DISCHARGE (RRTD)**

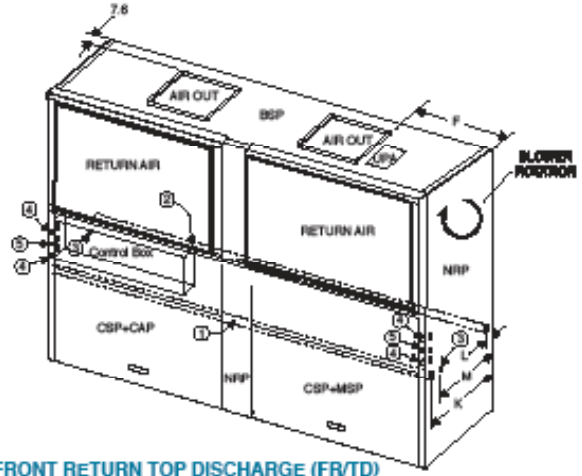

**FRONT RETURN TOP DISCHARGE (FRTD)**

LEGEND	168-240	300
1. Water Inlet (see note 2)	2" FPT	2 1/2" FPT
2. Water Outlet (see note 2)	2" FPT	2 1/2" FPT
3. Condensate Drain (see note 2)	1" FPT	
4. High Voltage Access (see note 4)	1x2" BS-35 and 1x2" (2.2 cm)	
BSP - Blower Service Panel GAP - Control Access Panel CSP - Compressor Access Panel MSP - Motor Service Panel NFP - Non-Financial Panel UFA - Upper Pulley Access		

**NOTES:**

- All dimensions in inches (cm)
- Water Inlet and water outlet connections are available on either side (left or right) of the unit. Installer must plug water inlet/outlet not being connected to.
- Condensate drain is available on either side (left or right) of unit. Drain hose and drain connection will be tied inside the unit. Installer will write the drain hose, form trap, and connect to the condensate drain hole of installer's choice.
- Electrical access is available on either side (left or right) of unit and is also available in the front on the left or right side of the unit.
- Overall Depth - Add 5.12" (13 cm) for 1" (2.5 cm) or 2" (5 cm) Filter Frame; 5.12" for 4" Filter Frame and for FD, FD additional 1.06" (2.7 cm) for supply air duct flange.
- Overall cabinet height dimension does not include duct flange when in top discharge configuration.
- While access to all removable panels may not be required, installer should take care to comply with all building codes and allow adequate clearance for future field service.
- Units require 5 feet (151 cm) clearance for water connections, GAP, CSP, MSP and BSP service access.
- Side service access must be 2 feet (61 cm) on any side that connections are made. If no connections are made on a side then service access can be 6 inches (15 cm) minimum.
- Filter removed is from bottom of frame, allow 2 feet (61 cm) access for servicing.

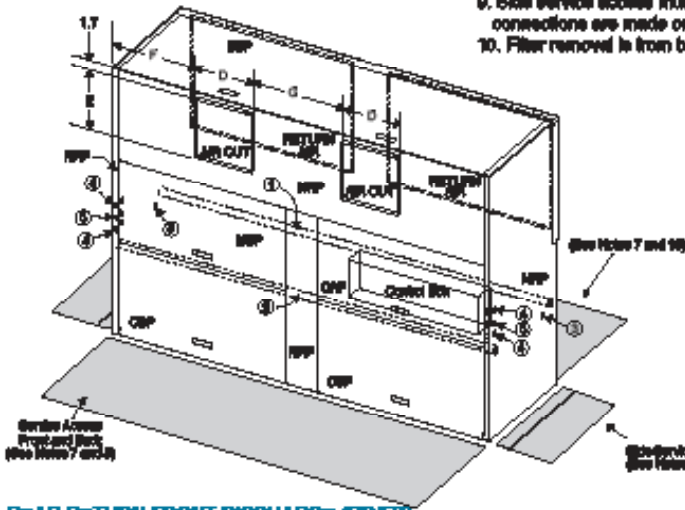

**REAR RETURN FRONT DISCHARGE (RRFD)**

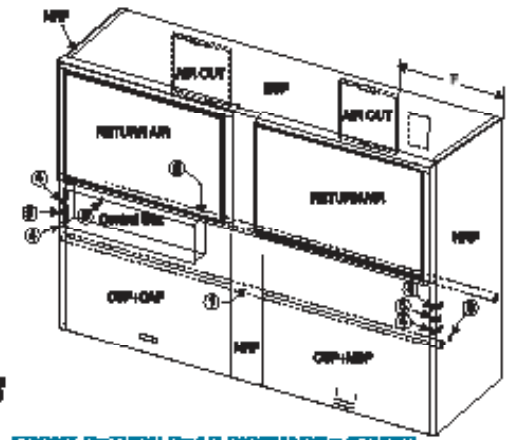

**FRONT RETURN REAR DISCHARGE (FRRD)**

Model	Overall Cabinet			Discharge Connections Duct Flange				Water Connections				Electrical Knockouts					Return Air Connections Using Return Air Opening			
	A	B	C	D	E	F	G	K	L	M	N	O1	O2	P	Q	R	S	T	U	V
	Depth Note 5	Width	Height Note 6	Supply Width	Supply Depth			1 Water Inlet	2 Water Outlet	3 Condensate							Return Depth	Return Height		
168-240	in.	34.0	106.7	79.0	17.5	17.6	17.8	31.0	3.0	27.0	25.6	31.0	38.0	34.6	1.0	3.0	48.0	32.4	44.6	2.7
	cm.	86.4	270.9	200.7	44.5	44.6	45.1	78.7	7.6	68.6	65.1	78.7	96.4	87.8	2.5	7.6	121.9	82.2	113.3	6.9
300	in.	34.0	106.7	79.0	21.4	17.6	17.8	31.0	3.0	27.0	25.6	31.0	38.0	34.6	1.0	3.0	48.0	32.4	44.6	2.7
	cm.	86.4	270.9	200.7	54.4	44.6	45.1	78.7	7.6	68.6	65.1	78.7	96.4	87.8	2.5	7.6	121.9	82.2	113.3	6.9

## HKV Electrical Data - Standard

Model	Voltage Code	Voltage	Min/Max Voltage	Blower Option	Compressor			Fan Motor FLA	Total Unit FLA	Min Circuit Amp	Max Fuse/HACR
					QTY	RLA	LRA				
HKV084	3	208-3-60	197/254	A, B, C	1	23.2	164.0	4.0	27.2	33.0	50
	3	208-3-60	197/254	D, E	1	23.2	164.0	5.0	28.2	34.0	50
	4	460-3-60	414/506	A, B, C	1	11.2	75.0	2.0	13.2	16.0	25
	4	460-3-60	414/506	D, E	1	11.2	75.0	2.4	13.6	16.4	25
	5	575-3-60	518/633	A, B, C	1	7.9	54.0	1.4	9.3	11.3	15
	5	575-3-60	518/633	D, E	1	7.9	54.0	1.9	9.8	11.8	15
HKV096	3	208-3-60	197/254	A, B, C	1	25.0	164.0	5.0	30.0	36.3	60
	3	208-3-60	197/254	D, E	1	25.0	164.0	6.2	31.2	37.5	60
	4	460-3-60	414/506	A, B, C	1	12.2	100.0	2.4	14.6	17.6	25
	4	460-3-60	414/506	D, E	1	12.2	100.0	3.1	15.3	18.4	30
	5	575-3-60	518/633	A, B, C	1	9.0	78.0	1.9	10.9	13.1	20
	5	575-3-60	518/633	D, E	1	9.0	78.0	2.3	11.3	13.6	20
HKV120	3	208-3-60	197/254	A, B, C	1	30.1	225.0	6.2	36.3	43.8	70
	3	208-3-60	197/254	D, E	1	30.1	225.0	9.2	39.3	46.8	70
	4	460-3-60	414/506	A, B, C	1	16.7	114.0	3.1	19.8	24.0	40
	4	460-3-60	414/506	D, E	1	16.7	114.0	4.3	21.0	25.2	40
	5	575-3-60	518/633	A, B, C	1	12.2	80.0	2.3	14.5	17.5	25
	5	575-3-60	518/633	D, E	1	12.2	80.0	3.4	15.6	18.6	30
HKV150	3	208-3-60	197/254	A, B, C	1	48.1	245.0	9.2	57.3	69.3	110
	3	208-3-60	197/254	D, E	1	48.1	245.0	14.1	62.2	74.2	110
	4	460-3-60	414/506	A, B, C	1	18.6	125.0	4.3	22.9	27.6	45
	4	460-3-60	414/506	D, E	1	18.6	125.0	7.0	25.6	30.3	45
	5	575-3-60	518/633	A, B, C	1	14.7	100.0	3.4	18.1	21.8	35
	5	575-3-60	518/633	D, E	1	14.7	100.0	5.2	19.9	23.6	35
HKV168	3	208-3-60	197/254	A, B, C	2	23.2	164.0	6.2	52.6	58.4	80
	3	208-3-60	197/254	D, E	2	23.2	164.0	9.2	55.6	61.4	80
	4	460-3-60	414/506	A, B, C	2	11.2	75.0	3.1	25.5	28.3	35
	4	460-3-60	414/506	D, E	2	11.2	75.0	4.3	26.7	29.5	40
	5	575-3-60	518/633	A, B, C	2	7.9	54.0	2.3	18.1	20.1	25
	5	575-3-60	518/633	D, E	2	7.9	54.0	3.4	19.2	21.2	25
HKV192	3	208-3-60	197/254	A, B, C	2	25.0	164.0	9.2	59.2	65.4	90
	3	208-3-60	197/254	D, E	2	25.0	164.0	14.1	64.1	70.3	90
	4	460-3-60	414/506	A, B, C	2	12.2	100.0	4.3	28.7	31.8	40
	4	460-3-60	414/506	D, E	2	12.2	100.0	7.0	31.4	34.5	45
	5	575-3-60	518/633	A, B, C	2	9.0	78.0	3.4	21.4	23.6	30
	5	575-3-60	518/633	D, E	2	9.0	78.0	5.2	23.2	25.5	30
HKV240	3	208-3-60	197/254	A, B, C	2	30.1	225.0	14.1	74.3	81.8	110
	3	208-3-60	197/254	E	2	30.1	225.0	21.7	81.9	89.4	110
	4	460-3-60	414/506	A, B, C	2	16.7	114.0	7.0	40.4	44.6	60
	4	460-3-60	414/506	E	2	16.7	114.0	10.0	43.4	47.6	60
	5	575-3-60	518/633	A, B, C	2	12.2	80.0	5.2	29.6	32.6	40
	5	575-3-60	518/633	E	2	12.2	80.0	7.7	32.1	35.1	45
HKV300	3	208-3-60	197/254	A, B, C	2	48.1	245.0	14.1	110.3	122.3	150
	3	208-3-60	197/254	D, E	2	48.1	245.0	21.7	117.9	129.9	175
	4	460-3-60	414/506	A, B, C	2	18.6	125.0	7.0	44.2	48.9	60
	4	460-3-60	414/506	D, E	2	18.6	125.0	10.0	47.2	51.9	70
	5	575-3-60	518/633	A, B, C	2	14.7	100.0	5.2	34.6	38.3	50
	5	575-3-60	518/633	D, E	2	14.7	100.0	7.7	37.1	40.8	50

HACR circuit breaker in USA only  
All fuses Class RK-5

# HKV Electrical Data - Dual Point Power

Model	Voltage Code	Voltage	Min/Max Voltage	Blower Option	Compressor						Emergency Power Supply		
					QTY	RLA	LRA	Total Comp FLA	Comp MCA	Comp Max Fuse/HACR	Total Unit FLA	Min Circuit Amp	Max Fuse/HACR
HKV084	3	208-3-60	197/254	A, B, C	1	23.2	164.0	23.2	29.0	50	4.0	5.0	15
	3	208-3-60	197/254	D, E	1	23.2	164.0	23.2	29.0	50	5.0	6.3	15
	4	460-3-60	414/506	A, B, C	1	11.2	75.0	11.2	38.0	25	2.0	2.5	15
	4	460-3-60	414/506	D, E	1	11.2	75.0	11.2	38.0	25	2.4	3.0	15
	5	575-3-60	518/633	A, B, C	1	7.9	54.0	7.9	9.9	15	1.4	1.8	15
	5	575-3-60	518/633	D, E	1	7.9	54.0	7.9	9.9	15	1.9	2.4	15
HKV096	3	208-3-60	197/254	A, B, C	1	25.0	164.0	25.0	31.3	50	5.0	6.3	15
	3	208-3-60	197/254	D, E	1	25.0	164.0	25.0	31.3	50	6.2	7.8	15
	4	460-3-60	414/506	A, B, C	1	12.2	100.0	12.2	15.3	25	2.4	3.0	15
	4	460-3-60	414/506	D, E	1	12.2	100.0	12.2	15.3	25	3.1	3.9	15
	5	575-3-60	518/633	A, B, C	1	9.0	78.0	9.0	11.3	20	1.9	2.4	15
	5	575-3-60	518/633	D, E	1	9.0	78.0	9.0	11.3	20	2.3	2.9	15
HKV120	3	208-3-60	197/254	A, B, C	1	30.1	225.0	30.1	37.6	60	6.2	7.8	15
	3	208-3-60	197/254	D, E	1	30.1	225.0	30.1	37.6	60	9.2	11.5	20
	4	460-3-60	414/506	A, B, C	1	16.7	114.0	16.7	20.9	35	3.1	3.9	15
	4	460-3-60	414/506	D, E	1	16.7	114.0	16.7	20.9	35	4.3	5.4	15
	5	575-3-60	518/633	A, B, C	1	12.2	80.0	12.2	15.3	25	2.3	2.9	15
	5	575-3-60	518/633	D, E	1	12.2	80.0	12.2	15.3	25	3.4	4.3	15
HKV150	3	208-3-60	197/254	A, B, C	1	48.1	245.0	48.1	60.1	100	9.2	11.5	20
	3	208-3-60	197/254	D, E	1	48.1	245.0	48.1	60.1	100	14.1	17.6	30
	4	460-3-60	414/506	A, B, C	1	18.6	125.0	18.6	23.3	40	4.3	5.4	15
	4	460-3-60	414/506	D, E	1	18.6	125.0	18.6	23.3	40	7.0	8.8	15
	5	575-3-60	518/633	A, B, C	1	14.7	100.0	14.7	18.4	30	3.4	4.3	15
	5	575-3-60	518/633	D, E	1	14.7	100.0	14.7	18.4	30	5.2	6.5	15
HKV168	3	208-3-60	197/254	A, B, C	2	23.2	164.0	46.4	52.2	70	6.2	7.8	15
	3	208-3-60	197/254	D, E	2	23.2	164.0	46.4	52.2	70	9.2	11.5	20
	4	460-3-60	414/506	A, B, C	2	11.2	75.0	22.4	25.2	35	3.1	3.9	15
	4	460-3-60	414/506	D, E	2	11.2	75.0	22.4	25.2	35	4.3	5.4	15
	5	575-3-60	518/633	A, B, C	2	7.9	54.0	15.8	17.8	25	2.3	2.9	15
	5	575-3-60	518/633	D, E	2	7.9	54.0	15.8	17.8	25	3.4	4.3	15
HKV192	3	208-3-60	197/254	A, B, C	2	25.0	164.0	50.0	56.3	80	9.2	11.5	20
	3	208-3-60	197/254	D, E	2	25.0	164.0	50.0	56.3	80	14.1	17.6	30
	4	460-3-60	414/506	A, B, C	2	12.2	100.0	24.4	27.4	35	4.3	5.4	15
	4	460-3-60	414/506	D, E	2	12.2	100.0	24.4	27.4	35	7.0	8.8	15
	5	575-3-60	518/633	A, B, C	2	9.0	78.0	18.0	20.3	25	3.4	4.3	15
	5	575-3-60	518/633	D, E	2	9.0	78.0	18.0	20.3	25	5.2	6.5	15
HKV240	3	208-3-60	197/254	A, B, C	2	30.1	225.0	60.2	67.7	90	14.1	17.6	30
	3	208-3-60	197/254	E	2	30.1	225.0	60.2	67.7	90	21.7	27.1	45
	4	460-3-60	414/506	A, B, C	2	16.7	114.0	33.4	37.6	50	7.0	8.8	15
	4	460-3-60	414/506	E	2	16.7	114.0	33.4	37.6	50	10.0	12.5	20
	5	575-3-60	518/633	A, B, C	2	12.2	80.0	24.4	27.4	35	5.2	6.5	15
	5	575-3-60	518/633	E	2	12.2	80.0	24.4	27.4	35	7.7	9.6	15
HKV300	3	208-3-60	197/254	A, B, C	2	48.1	245.0	96.2	108.2	150	14.1	17.6	30
	3	208-3-60	197/254	D, E	2	48.1	245.0	96.2	108.2	150	21.7	27.1	45
	4	460-3-60	414/506	A, B, C	2	18.6	125.0	37.2	41.9	60	7.0	8.8	15
	4	460-3-60	414/506	D, E	2	18.6	125.0	37.2	41.9	60	10.0	12.5	20
	5	575-3-60	518/633	A, B, C	2	14.7	100.0	29.4	33.1	45	5.2	6.5	15
	5	575-3-60	518/633	D, E	2	14.7	100.0	29.4	33.1	45	7.7	9.6	15

HACR circuit breaker in USA only  
All fuses Class RK-5

## HKV Electrical Data Standard with Internal Pump or ClimaDry®

Model	Voltage Code	Voltage	Min/Max Voltage	Blower Option	Compressor			Fan Motor FLA	Pump		Total Unit FLA	Min Circuit Amp	Max Fuse / HACR
					QTY	RLA	LRA		QTY	FLA			
HKV084	3	208-3-60	197/254	A, B, C	1	23.2	164.0	4.0	1	1.10	28.3	34.1	50
	3	208-3-60	197/254	D, E	1	23.2	164.0	5.0	1	1.10	29.3	35.1	50
	4	460-3-60	414/506	A, B, C	1	11.2	75.0	2.0	1	0.55	13.8	16.5	25
	4	460-3-60	414/506	D, E	1	11.2	75.0	2.4	1	0.55	14.1	17.0	25
	5	575-3-60	518/633	A, B, C	1	7.9	54.0	1.4	1	0.44	9.7	11.7	15
	5	575-3-60	518/633	D, E	1	7.9	54.0	1.9	1	0.44	10.2	12.2	20
HKV096	3	208-3-60	197/254	A, B, C	1	25.0	164.0	5.0	1	1.96	32.0	38.2	60
	3	208-3-60	197/254	D, E	1	25.0	164.0	6.2	1	1.96	33.2	39.4	60
	4	460-3-60	414/506	A, B, C	1	12.2	100.0	2.4	1	0.98	15.6	18.6	30
	4	460-3-60	414/506	D, E	1	12.2	100.0	3.1	1	0.98	16.3	19.3	30
	5	575-3-60	518/633	A, B, C	1	9.0	78.0	1.9	1	0.78	11.7	13.9	20
	5	575-3-60	518/633	D, E	1	9.0	78.0	2.3	1	0.78	12.1	14.3	20
HKV120	3	208-3-60	197/254	A, B, C	1	30.1	225.0	6.2	1	1.96	38.3	45.8	70
	3	208-3-60	197/254	D, E	1	30.1	225.0	9.2	1	1.96	41.3	48.8	70
	4	460-3-60	414/506	A, B, C	1	16.7	114.0	3.1	1	0.98	20.8	25.0	40
	4	460-3-60	414/506	D, E	1	16.7	114.0	4.3	1	0.98	22.0	26.2	40
	5	575-3-60	518/633	A, B, C	1	12.2	80.0	2.3	1	0.78	15.3	18.3	30
	5	575-3-60	518/633	E	1	12.2	80.0	3.4	1	0.78	16.4	19.4	30
HKV150	3	208-3-60	197/254	A, B, C	1	48.1	245.0	9.2	1	1.96	59.3	71.3	110
	3	208-3-60	197/254	D, E	1	48.1	245.0	14.1	1	1.96	64.2	76.2	110
	4	460-3-60	414/506	A, B, C	1	18.6	125.0	4.3	1	0.98	23.9	28.5	45
	4	460-3-60	414/506	D, E	1	18.6	125.0	7.0	1	0.98	26.6	31.2	45
	5	575-3-60	518/633	A, B, C	1	14.7	100.0	3.4	1	0.78	18.9	22.6	35
	5	575-3-60	518/633	D, E	1	14.7	100.0	5.2	1	0.78	20.7	24.4	35
HKV168	3	208-3-60	197/254	A, B, C	2	23.2	164.0	6.2	2	1.10	54.8	60.6	80
	3	208-3-60	197/254	D, E	2	23.2	164.0	9.2	2	1.10	57.8	63.6	80
	4	460-3-60	414/506	A, B, C	2	11.2	75.0	3.1	2	0.55	26.6	29.4	40
	4	460-3-60	414/506	D, E	2	11.2	75.0	4.3	2	0.55	27.8	30.6	40
	5	575-3-60	518/633	A, B, C	2	7.9	54.0	2.3	2	0.44	19.0	21.0	25
	5	575-3-60	518/633	D, E	2	7.9	54.0	3.4	2	0.44	20.1	22.1	25
HKV192	3	208-3-60	197/254	A, B, C	2	25.0	164.0	9.2	2	1.96	63.1	69.4	90
	3	208-3-60	197/254	D, E	2	25.0	164.0	14.1	2	1.96	68.0	74.3	90
	4	460-3-60	414/506	A, B, C	2	12.2	100.0	4.3	2	0.98	30.7	33.7	45
	4	460-3-60	414/506	D, E	2	12.2	100.0	7.0	2	0.98	33.4	36.4	45
	5	575-3-60	518/633	A, B, C	2	9.0	78.0	3.4	2	0.78	23.0	25.2	30
	5	575-3-60	518/633	D, E	2	9.0	78.0	5.2	2	0.78	24.8	27.0	35
HKV240	3	208-3-60	197/254	A, B, C	2	30.1	225.0	14.1	2	1.96	78.2	85.7	110
	3	208-3-60	197/254	E	2	30.1	225.0	21.7	2	1.96	85.8	93.3	110
	4	460-3-60	414/506	A, B, C	2	16.7	114.0	7.0	2	0.98	42.4	46.5	60
	4	460-3-60	414/506	E	2	16.7	114.0	10.0	2	0.98	45.4	49.5	60
	5	575-3-60	518/633	A, B, C	2	12.2	80.0	5.2	2	0.78	31.2	34.2	45
	5	575-3-60	518/633	E	2	12.2	80.0	7.7	2	0.78	33.7	36.7	45
HKV300	3	208-3-60	197/254	A, B, C	2	48.1	245.0	14.1	2	1.96	114.2	126.2	150
	3	208-3-60	197/254	D, E	2	48.1	245.0	21.7	2	1.96	121.8	133.8	175
	4	460-3-60	414/506	A, B, C	2	18.6	125.0	7.0	2	0.98	46.2	50.8	60
	4	460-3-60	414/506	D, E	2	18.6	125.0	10.0	2	0.98	49.2	53.8	70
	5	575-3-60	518/633	A, B, C	2	14.7	100.0	5.2	2	0.78	36.2	39.8	50
	5	575-3-60	518/633	D, E	2	14.7	100.0	7.7	2	0.78	38.7	42.3	50

HACR circuit breaker in USA only  
All fuses Class RK-5

# HKV Electrical Data - Dual Point Power with Pump or ClimaDry®

Model	Voltage Code	Voltage	Min/Max Voltage	Blower Option	Compressor								Emergency Power Supply		
					QTY	RLA	LRA	QTY	Pump FLA	Total FLA	MCA	Max Fuse/HACR	Fan Motor FLA	Fan MCA	Fan Max Fuse/HACR
	3	208-3-60	197/254	A, B, C	1	23.2	164.0	1	1.10	24.3	30.1	50	4.0	5.0	15
	3	208-3-60	197/254	D, E	1	23.2	164.0	1	1.10	24.3	30.1	50	5.0	6.3	15
	4	460-3-60	414/506	A, B, C	1	11.2	75.0	1	0.55	11.8	14.6	25	2.0	2.5	15
	4	460-3-60	414/506	D, E	1	11.2	75.0	1	0.55	11.8	14.6	25	2.4	3.0	15
	5	575-3-60	518/633	A, B, C	1	7.9	54.0	1	0.44	8.3	10.3	15	1.4	1.8	15
	5	575-3-60	518/633	D, E	1	7.9	54.0	1	0.44	8.3	10.3	15	1.9	2.4	15
	3	208-3-60	197/254	A, B, C	1	25.0	164.0	1	1.96	27.0	33.2	50	5.0	6.3	15
	3	208-3-60	197/254	D, E	1	25.0	164.0	1	1.96	27.0	33.2	50	6.2	7.8	15
	4	460-3-60	414/506	A, B, C	1	12.2	100.0	1	0.98	13.2	16.2	25	2.4	3.0	15
	4	460-3-60	414/506	D, E	1	12.2	100.0	1	0.98	13.2	16.2	25	3.1	3.9	15
	5	575-3-60	518/633	A, B, C	1	9.0	78.0	1	0.78	9.8	12.0	20	1.9	2.4	15
	5	575-3-60	518/633	D, E	1	9.0	78.0	1	0.78	9.8	12.0	20	2.3	2.9	15
	3	208-3-60	197/254	A, B, C	1	30.1	225.0	1	1.96	32.1	39.6	60	6.2	7.8	15
	3	208-3-60	197/254	D, E	1	30.1	225.0	1	1.96	32.1	39.6	60	9.2	11.5	20
	4	460-3-60	414/506	A, B, C	1	16.7	114.0	1	0.98	17.7	21.9	35	3.1	3.9	15
	4	460-3-60	414/506	D, E	1	16.7	114.0	1	0.98	17.7	21.9	65	4.3	5.4	15
	5	575-3-60	518/633	A, B, C	1	12.2	80.0	1	0.78	13.0	16.0	25	2.3	2.9	15
	5	575-3-60	518/633	E	1	12.2	80.0	1	0.78	13.0	16.0	25	3.4	4.3	15
	3	208-3-60	197/254	A, B, C	1	48.1	245.0	1	1.96	50.1	62.1	110	9.2	11.5	20
	3	208-3-60	197/254	D, E	1	48.1	245.0	1	1.96	50.1	62.1	110	14.1	17.6	30
	4	460-3-60	414/506	A, B, C	1	18.6	125.0	1	0.98	19.6	24.2	40	4.3	5.4	15
	4	460-3-60	414/506	D, E	1	18.6	125.0	1	0.98	19.6	24.2	40	7.0	8.8	15
	5	575-3-60	518/633	A, B, C	1	14.7	100.0	1	0.78	15.5	19.2	30	3.4	4.3	15
	5	575-3-60	518/633	D, E	1	14.7	100.0	1	0.78	15.5	19.2	30	5.2	6.5	15
	3	208-3-60	197/254	A, B, C	2	23.2	164.0	2	1.10	48.6	54.4	70	6.2	7.8	15
	3	208-3-60	197/254	D, E	2	23.2	164.0	2	1.10	48.6	54.4	70	9.2	11.5	20
	4	460-3-60	414/506	A, B, C	2	11.2	75.0	2	0.55	23.5	26.3	35	3.1	3.9	15
	4	460-3-60	414/506	D, E	2	11.2	75.0	2	0.55	23.5	26.3	35	4.3	5.4	15
	5	575-3-60	518/633	A, B, C	2	7.9	54.0	2	0.44	16.7	18.7	25	2.3	2.9	15
	5	575-3-60	518/633	D, E	2	7.9	54.0	2	0.44	16.7	18.7	25	3.4	4.3	15
	3	208-3-60	197/254	A, B, C	2	25.0	164.0	2	1.96	53.9	60.2	80	9.2	11.5	20
	3	208-3-60	197/254	D, E	2	25.0	164.0	2	1.96	53.9	60.2	80	14.1	17.6	30
	4	460-3-60	414/506	A, B, C	2	12.2	100.0	2	0.98	26.4	29.4	40	4.3	5.4	15
	4	460-3-60	414/506	D, E	2	12.2	100.0	2	0.98	26.4	29.4	40	7.0	8.8	15
	5	575-3-60	518/633	A, B, C	2	9.0	78.0	2	0.78	19.6	21.8	30	3.4	4.3	15
	5	575-3-60	518/633	D, E	2	9.0	78.0	2	0.78	19.6	21.8	30	5.2	6.5	15
	3	208-3-60	197/254	A, B, C	2	30.1	225.0	2	1.96	64.1	71.6	100	14.1	17.6	30
	3	208-3-60	197/254	E	2	30.1	225.0	2	1.96	64.1	71.6	100	21.7	27.1	45
	4	460-3-60	414/506	A, B, C	2	16.7	114.0	2	0.98	35.4	39.5	50	7.0	8.8	15
	4	460-3-60	414/506	E	2	16.7	114.0	2	0.98	35.4	39.5	50	10.0	12.5	20
	5	575-3-60	518/633	A, B, C	2	12.2	80.0	2	0.78	26.0	29.0	40	5.2	6.5	15
	5	575-3-60	518/633	E	2	12.2	80.0	2	0.78	26.0	29.0	40	7.7	9.6	15
	3	208-3-60	197/254	A, B, C	2	48.1	245.0	2	1.96	100.1	112.1	150	14.1	17.6	30
	3	208-3-60	197/254	D, E	2	48.1	245.0	2	1.96	100.1	112.1	150	21.7	27.1	45
	4	460-3-60	414/506	A, B, C	2	18.6	125.0	2	0.98	39.2	43.8	60	7.0	8.8	15
	4	460-3-60	414/506	D, E	2	18.6	125.0	2	0.98	39.2	43.8	60	10.0	12.5	20
	5	575-3-60	518/633	A, B, C	2	14.7	100.0	2	0.78	31.0	34.6	45	5.2	6.5	15
	5	575-3-60	518/633	D, E	2	14.7	100.0	2	0.78	31.0	34.6	45	7.7	9.6	15

HACR circuit breaker in USA only  
All fuses Class RK-5

# HKV Series Wiring Diagram Matrix

Model	Wiring Diagram Part Number	Electrical	Control	Agency
<b>HKV084-150</b>	96B0113N01	208-230/60/3, 460/60/3, 575/60/3	CXM	ETL
	96B0113N02		DXM2	
<b>HKV084-150 with ClimaDry*</b>	96B0113N03		DXM2	
<b>HKV168-300</b>	96B0113N07		CXM	
	96B0113N08		DXM2	
<b>HKV186-300 with ClimaDry*</b>	96B0128N02		DXM2	
<b>HKV - All Auxillary Diagrams</b>	96B0149N01		CXM & LON	
	96B0149N02		DXM2 & LON	
	96B0149N03		CXM & MPC	
	96B0149N04		DXM2 & MPC	

# Typical Wiring Diagram - Three Phase HKV084-150 with CXM Controller

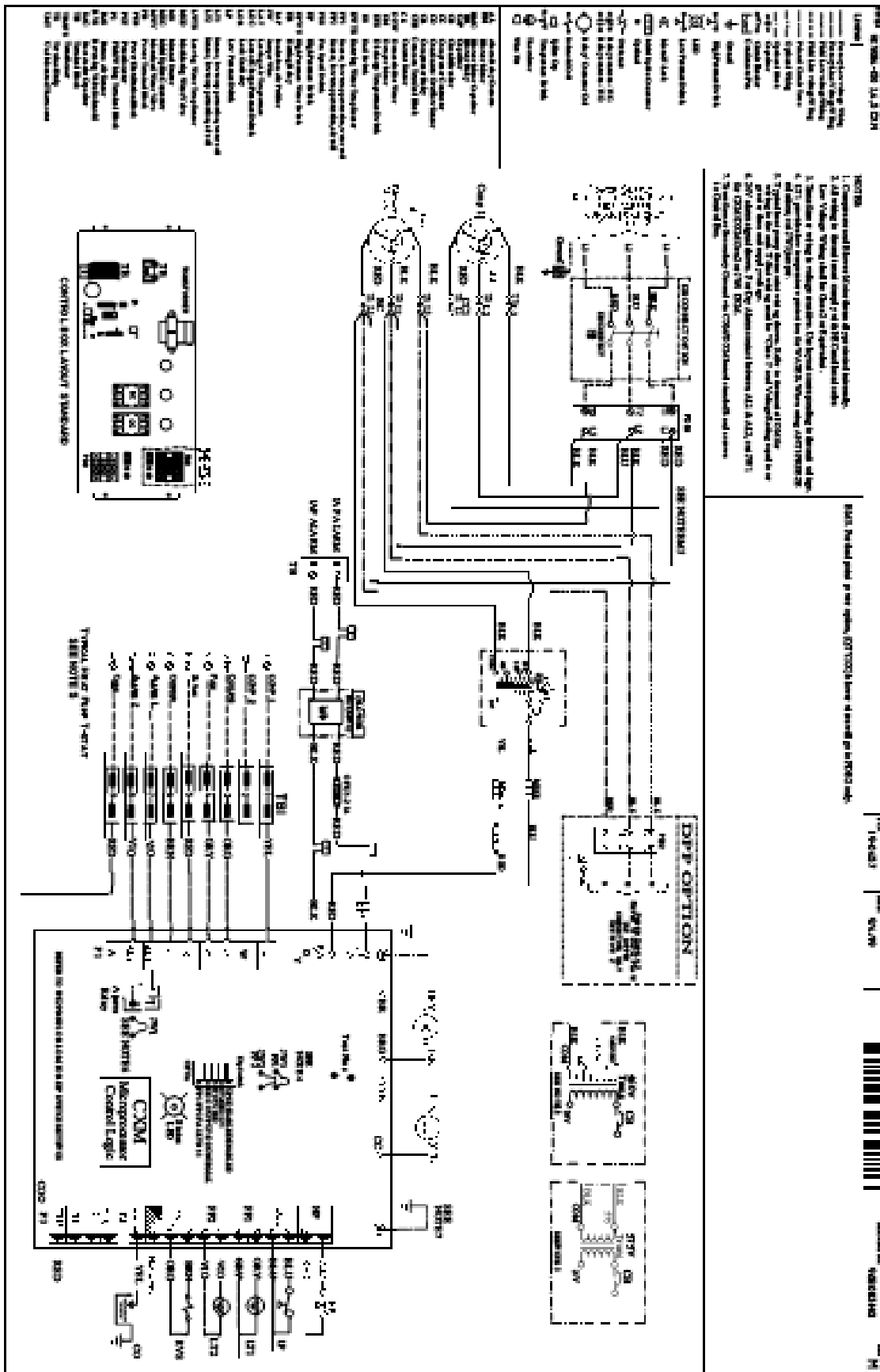

# Typical Wiring Diagram - Three Phase HKV084-150 with DXM2 Controller

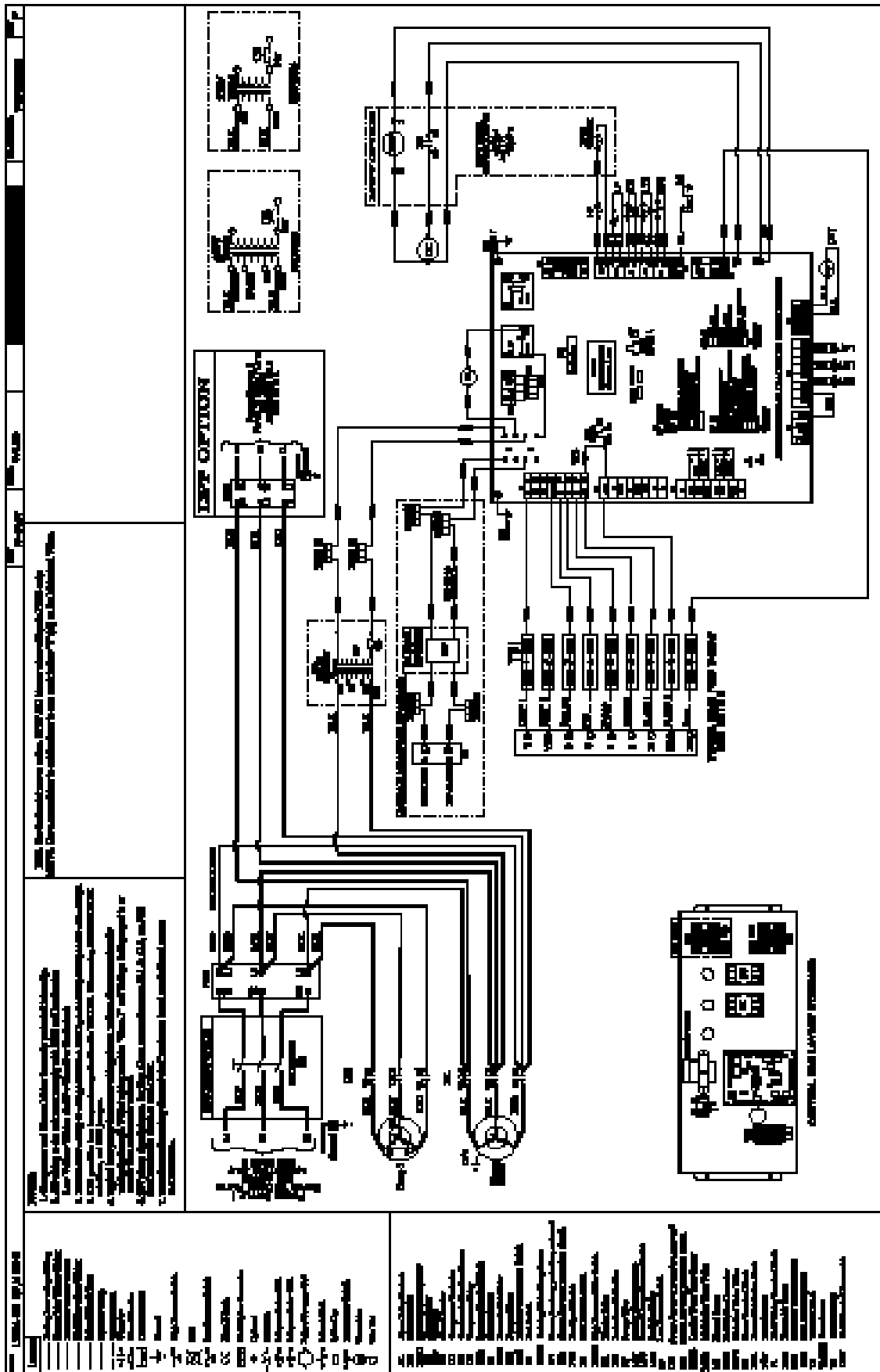

**General:**

Furnish and install Comfort-Aire/Century HKV Large Water Source Heat Pumps, as indicated on the plans. Equipment shall be completely assembled, piped, and internally wired. Capacities and characteristics as listed in the schedule and the specifications that follow.

Units shall be supplied completely factory built capable of operating over an entering water temperature range from 20° to 120°F (-6.7° to 48.9°C) as standard. Equivalent units from other manufacturers may be proposed provided approval to bid is given 10 days prior to bid closing. All equipment listed in this section must be rated and certified in accordance with Air-Conditioning, Heating and Refrigeration Institute/International Standards Organization (AHRI / ISO 13256-1). All equipment must be tested, investigated, and determined to comply with the requirements of the standards for Heating and Cooling Equipment UL-1995 for the United States and CAN/CSA-C22.2 NO.236 for Canada, by Intertek Testing Laboratories (ETL). The units shall have AHRI / ISO and ETL-US-C labels.

All units shall pass a factory acceptance test. The quality control system shall automatically perform factory acceptance test via computer. A detailed report card from the factory acceptance test shall ship with each unit. (Note: If unit fails the factory acceptance test, it shall not be allowed to ship. Unit serial number shall be recorded by factory acceptance test and furnished on report card for ease of unit warranty status.)

**Basic Construction:**

Vertical Units shall have one of the following air flow arrangements: Back Return/Top Discharge, Front Return/Top Discharge, Back Return/Front Discharge, Front Return/Back Discharge as shown on the plans. Units can be field converted without requiring new panels or belts. Units that cannot be field converted shall not be acceptable.

If units with these arrangements are not used, the contractor is responsible for any extra costs incurred by other trades. All units must have a minimum of two access panels for serviceability of compressor compartment. Units having only one access panel to compressor/heat exchangers/expansion device/refrigerant piping shall not be acceptable.

Compressor section interior surfaces shall be lined with 1/2 inch (12.7mm) thick, 1-1/2 lb/ft<sup>3</sup> (24 kg/m<sup>3</sup>) acoustic type glass fiber insulation. Air handling section interior surfaces shall be lined with 1/2 inch (12.7mm) thick, 1-1/2 lb/ft<sup>3</sup> (24 kg/m<sup>3</sup>) foil backed fiber insulation for ease of cleaning. Insulation placement shall be designed in a manner that will eliminate any exposed edges to prevent the introduction of glass fibers into the air stream. Units without foil-faced insulation in the air handling section will not be accepted.

Vertical heat pumps shall be fabricated from heavy gauge galvanized steel.

Standard insulation must meet NFPA Fire Hazard Classification requirements 25/50 per ASTM E84, UL 723, CAN/ULC S102-M88 and NFPA 90A requirements; air erosion and mold growth limits of UL-181; stringent fungal resistance test per ASTM-C1071 and ASTM G21; and shall meet zero level bacteria growth per ASTM G22. Unit insulation must meet these stringent requirements or unit(s) will not be accepted.

HKV Large Series 60Hz  
Engineering Specifications - Page 2

Vertical units to have discharge air duct collar and 1 inch (25.4mm) full filter frame with 1 inch (25.4mm) filters factory installed. If units with these factory installed provisions are not used, the contractor is responsible for any extra costs to field install these provisions, and/or the extra costs for his sub-contractor to install these provisions.

All units must have an insulated panel separating the fan compartment from the compressor compartment. Units with the compressor in the air stream are not acceptable. Units shall have a factory installed 1 inch (25.4mm) wide filter frame with filter removal from bottom side. Units shall have a 1 inch (25.4mm) thick throwaway type glass fiber filter. The contractor shall purchase one spare set of filters and replace factory shipped filters on completion of start-up. Filters shall be standard sizes. If units utilize non-standard filter sizes then the contractor shall provide 12 spare filters for each unit.

Cabinets shall have separate knockouts on front and sides for entrance of line voltage and low voltage control wiring. All factory-installed wiring passing through factory knockouts and openings shall be protected from sheet metal edges at openings by plastic ferrules. Supply and return water connections shall be copper FPT fittings, connections on both sides (installer to choose side and plug opposite) and shall be securely mounted flush to the cabinet side allowing for connection of a flexible hose without the use of a back-up wrench. Water connections that protrude through the cabinet or require the use of a backup wrench shall not be allowed. Water connections on only one side will not be accepted. All water connections and electrical knockouts must not interfere with the serviceability of unit. Contractor shall be responsible for any extra costs involved in the installation of units that do not have this feature. Contractor must ensure that units can be easily removed for servicing and coordinate locations of electrical conduit and lights with the electrical contractor.

Option: 2-inch (50.8mm) full filter frame with glass fiber throwaway filters on units.

Option: 4-inch (101.6 mm) full filter frame with Merv 8 Filter on units.

Option: UltraQuiet package shall consist of high technology sound attenuating material that is strategically applied to the compressor and air handling compartment casings and fan scroll in addition to the standard system design, to further dampen and attenuate sound transmissions. Compressor is mounted on specially engineered sound-tested isolators.

Option: The unit shall be supplied with extended range insulation option, which adds closed cell insulation to internal water lines, and provides insulation on suction side refrigeration tubing including refrigerant to water heat exchanger.

Option: The unit shall be supplied with internally factory mounted two-way water valve for variable speed pumping requirements. A factory-mounted or field-installed high pressure switch shall be installed in the water piping to disable compressor operation in the event water pressures build due to water freezing in the piping system.

Option: The unit shall be supplied with internally mounted secondary pump for primary/secondary applications.

**Fan and Motor Assembly:**

All units shall have belt-driven single or dual centrifugal fans. Fan motor shall be permanently lubricated with thermal overload protection. Units supplied without a permanently lubricated motor must provide external oilers for easy service. The fan and motor assembly must be capable of overcoming the external static pressures as shown on the schedule. Airflow / Static pressure rating of the unit shall be based on a wet coil and a clean filter in place. **Ratings based on a dry coil and/or no air filter shall NOT be acceptable.**

*Option: Various blower drive packages for selectable static pressure/airflow.*

**Refrigerant Circuit:**

All units shall contain an EarthPure® (HFC-410A) sealed refrigerant circuit including a high efficiency scroll compressor designed for heat pump operation, a thermostatic expansion valve for refrigerant metering, an enhanced corrugated aluminum lanced fin and rifled copper tube refrigerant to air heat exchanger, reversing valve, coaxial (tube in tube) refrigerant to water heat exchanger, and safety controls including a high pressure switch, low pressure switch (loss of charge), water coil low temperature sensor, and air coil low temperature sensor. Access fittings shall be factory installed on high and low pressure refrigerant lines to facilitate field service. Activation of any safety device shall prevent compressor operation via a microprocessor lockout circuit. The lockout circuit shall be reset at the thermostat or at the optional disconnect switch.

**Units that cannot be reset at the thermostat shall not be acceptable.**

Hermetic compressors shall be internally sprung. The scroll compressors shall have a dual level vibration isolation system. The compressor(s) will be mounted on specially engineered sound-tested EPDM vibration isolation grommets to a large heavy gauge compressor mounting plate, which is then isolated from the cabinet base with grommets for maximized vibration attenuation. Compressor shall have thermal overload protection. Compressor shall be located in an insulated compartment isolated from air stream to minimize sound transmission.

Refrigerant to air heat exchangers shall utilize enhanced corrugated lanced aluminum fins and rifled copper tube construction rated to withstand 625 PSIG (4309 kPa) refrigerant working pressure. Refrigerant to water heat exchangers shall be of copper inner water tube and steel refrigerant outer tube design, rated to withstand 625 PSIG (4309 kPa) working refrigerant pressure. The refrigerant to water heat exchanger shall be "electro-coated" with a low cure cathodic epoxy material a minimum of 0.4 mils thick (0.4 - 1.5 mils range) on all surfaces. The black colored coating shall provide a minimum of 1,000 hours salt spray protection per ASTM B117-97 on all external steel and copper tubing. The material shall be formulated without the inclusion of any heavy metals and shall exhibit a pencil hardness of 2H (ASTM D3363-92A), crosshatch adhesion of 4B-5B (ASTM D3359-95), and impact resistance of 160 in-lbs (184 kg-cm) direct (ASTM D2794-93).

Refrigerant metering shall be accomplished by thermostatic expansion valve only. Expansion valves shall be a dual port balanced type with external equalizer for optimum refrigerant metering. Units shall be designed and tested for operating ranges of entering water temperatures from 20° to 120°F (-6.7° to 48.9°C). Reversing valve shall be four-way solenoid activated refrigerant valve, which shall default to

HKV Large Series 60Hz  
Engineering Specifications - Page 4

heating mode should the solenoid fail to function. If the reversing valve solenoid defaults to cooling mode, an additional low temperature thermostat must be provided to prevent over-cooling an already cold room.

Option: The unit shall be supplied with cupro-nickel coaxial water to refrigerant heat exchanger.

Option: The refrigerant to air heat exchanger shall be coated.

Option: Unit shall include ClimaDry® II reheat option. Only modulating reheat that will adjust capacity based upon supply air temperature to provide "neutral" (72°F, 22.2°C) constant air temperature will be accepted. "Neutral" supply air temperature shall be provided regardless of entering loop water temperatures or refrigerant condensing pressures. Control of reheat must be accomplished via a humidistat or dehumidistat contact closure. Refrigerant circuit must be AHRI certified. Approved equal manufacturers may provide pre-engineered integrated modulating hot gas reheat within the unit cabinet. Any design costs and costs of field installed items shall be borne by mechanical contractor. Refrigerant circuits that are not AHRI certified when the reheat option is applied will not be accepted. (See ClimaDry® II submittal for application details and unit availability.)

**Drain Pan:**

The drain pan shall be constructed of galvanized steel and have a powder coat paint application to further inhibit corrosion. This corrosion protection system shall meet the stringent 1,000 hour salt spray test per ASTM B117. If plastic type material is used, it must be HDPE (High Density Polyethylene) to avoid thermal cycling shock stress failure over the lifetime of the unit. Drain pan shall be fully insulated. Drain outlet shall be located at pan as to allow complete and unobstructed drainage of condensate. Drain pan hose assembly can be connected to either side, drain outlet to be 1" FPT fitting. Choice of drain connection to only one side will not be accepted. The unit as standard will be supplied with solid-state electronic condensate overflow protection. Mechanical float switches will NOT be accepted.

Option: The unit shall be supplied with stainless steel drain pan.

**Electrical:**

A control box shall be located within the unit compressor compartment and shall contain a 75VA transformer with load side circuit breaker protection, 24 volt activated, 2 or 3 pole compressor contactor, terminal block for thermostat wiring and solid-state controller for complete unit operation. Reversing valve and fan motor wiring shall be routed through this electronic controller. Units shall be name-plated for use with time delay fuses or HACR circuit breakers. Unit controls shall be 24 Volt and provide heating or cooling as required by the remote thermostat/sensor. Two compressor units shall have a solid-state time delay relay and random start to prevent both compressors from starting simultaneously.

Option: The unit shall be supplied with electrical disconnect.

**Solid State Control System (CXM):**

Units shall have a solid-state control system. Units utilizing electro-mechanical control shall not be acceptable. The control system microprocessor board shall be specifically designed to protect against building electrical system noise contamination, EMI, and RFI interference. The control system shall interface with a heat pump type thermostat. The control system shall have the following features:

- a. Anti-short cycle time delay on compressor operation.
- b. Random start on power up mode.
- c. Low voltage protection.
- d. High voltage protection.
- e. Unit shutdown on high or low refrigerant pressures.
- f. Unit shutdown on low water temperature.
- g. Condensate overflow electronic protection.
- h. Option to reset unit at thermostat or disconnect.
- i. Automatic intelligent reset. Unit shall automatically reset the unit 5 minutes after trip if the fault has cleared. If a fault occurs 3 times sequentially without thermostat meeting temperature, then lockout requiring manual reset will occur.
- j. Ability to defeat time delays for servicing.
- k. Light emitting diode (LED) on circuit board to indicate high pressure, low pressure, low voltage, high voltage, low water/air temperature cut out, condensate overflow, and control voltage status.
- l. The low-pressure switch shall not be monitored for the first 120 seconds after a compressor start command to prevent nuisance safety trips.
- m. 24V output to cycle a motorized water valve or other device with compressor contactor.
- n. Unit Performance Sentinel (UPS). The UPS warns when the heat pump is running inefficiently.
- o. Water coil low temperature sensing (selectable for water or anti-freeze).
- p. Air coil low temperature sensing.

**NOTE: Units not providing the 8 safety protections of anti-short cycle, low voltage, high voltage, high refrigerant pressure, low pressure (loss of charge), air coil low temperature cut-out, water coil low temperature cut-out, and condensate overflow protections will not be accepted.**

**Option: Enhanced Solid State Control System (DXM2)**

This control system is a communicating controller; also features two stage control of cooling and two stage control of heating modes for exacting temperature and dehumidification purposes.

This control system, coupled with a multi-stage thermostat, will better dehumidify room air by automatically running the heat pump's fan at lower speed on the first stage of cooling thereby implementing low sensible heat ratio cooling. On the need for higher cooling performance, the system will activate the second stage of cooling and automatically switch the fan to the higher fan speed setting. This system may be further enhanced with a humidistat. Units not having automatic low sensible heat ratio cooling will not be accepted; as an alternate, a hot gas reheat coil may be provided with control system for automatic reactivation.

This controller shall have sensors to monitor entering water, leaving water, supply air, and compressor discharge line temperatures. Temperatures can be read by using service tool or communicating thermostat.

Control shall have all of the above-mentioned features of the CXM control system along with the following expanded features:

# HKV Large Series 60Hz Engineering Specifications – Page 6

- a. Removable thermostat connector.
- b. Night setback control.
- c. Random start on return from night setback.
- d. Minimized reversing valve operation (Unit control logic shall only switch the reversing valve when cooling is demanded for the first time. The reversing valve shall be held in this position until the first call for heating, ensuring quiet operation and increased valve life.).
- e. Override temperature control with 2-hour timer for room occupant to override setback temperature at the thermostat.
- f. Dry contact night setback output for digital night setback thermostats.
- g. Ability to work with heat pump or heat/cool (Y, W) type thermostats.
- h. Ability to work with heat pump thermostats using O or B reversing valve control.
- i. Emergency shutdown contacts.
- j. Boilerless system heat control at low loop water temperature.
- k. Ability to allow up to 3 units to be controlled by one thermostat.
- l. Relay to operate an external damper.
- m. Ability to automatically change fan speed from multistage thermostat.
- n. Relay to start system pump.
- o. 75 VA control transformer. Control transformer shall have load side short circuit and overload protection via a built in circuit breaker.
- p. Entering water temperature sensing.
- q. Leaving water temperature sensing.
- r. Leaving air temperature sensing.
- s. Discharge line air temperature sensing.

**NOTE: Units not providing the 8 safety protections of anti-short cycle, low voltage, high voltage, high refrigerant pressure, low pressure (loss of charge), air coil low temperature cut-out, water coil low temperature cut-out, and condensate overflow protections for both drains will not be accepted.**

When DXM2 is connected to either 7602-444 service tool or 7602-457 thermostat, the installer/ technician can; check and set SFM; check DIP switch S1, S2, and S3 settings; run operation modes manually; check all physical inputs from thermostat and refrigerant pressure switches status (Y1, Y2, W, O, G, H, ESD, NSB, OR, HP switch, and LOC switch); current or at time of fault the following temperatures -LT1, LT2, compressor discharge, leaving air, leaving water, entering water and control voltage; record last five faults, list possible reasons, and clear faults.

#### **Digital Night Setback with Pump Restart (DXM2 w/ 7602-457):**

The unit will be provided with a Digital Night Setback feature using an accessory relay on the DXM2 controller with an 7602-457 thermostat and an external, field-provided time clock. The external time clock will initiate and terminate the night setback period. The thermostat will have a night setback override feature with a programmable override time period.

An additional accessory relay on the unit DXM2 controller will energize the building loop pump control for the duration of the override period. **(Note: this feature requires additional low voltage wiring. Consult Application Drawings for details.)**

#### **Remote Service Sentinel (CXM/DXM2):**

Solid state control system shall communicate with thermostat to display (at the thermostat) the unit status, fault status, and specific fault condition, as well as retrieve previously stored fault that caused unit shutdown. The Remote Service Sentinel allows building maintenance personnel or service

personnel to diagnose unit from the wall thermostat. The control board shall provide a signal to the thermostat fault light, indicating a lockout. Upon cycling the G (fan) input 3 times within a 60 second time period, the fault light shall display the specific code as indicated by a sequence of flashes. A detailed flashing code shall be provided at the thermostat LED to display unit status and specific fault status such as over/under voltage fault, high pressure fault, low pressure fault, low water temperature fault, condensate overflow fault, etc. **Units that do not provide this remote service sentinel shall not be acceptable.**

**Option: Lonworks interface system**

Units shall have all the features listed above (either CXM or DXM2) and the control board will be supplied with a LONWORKS interface board, which is LONMark certified. This will permit all units to be daisy chained via a 2-wire twisted pair shielded cable. The following points must be available at a central or remote computer location:

- a. Space temperature
- b. Leaving water temperature
- c. Discharge air temperature
- d. Command of space temperature setpoint
- e. Cooling status
- f. Heating status
- g. Low temperature sensor alarm
- h. Low pressure sensor alarm
- i. High pressure switch alarm
- j. Condensate sensor alarm
- k. Hi/low voltage alarm
- l. Fan "ON/AUTO" position of space thermostat as specified above
- m. Unoccupied / occupied command
- n. Cooling command
- o. Heating command
- p. Fan "ON/AUTO" command
- q. Fault reset command
- r. Itemized fault code revealing reason for specific shutdown fault (any one of 7)

This option also provides the upgraded 75VA control transformer with load side short circuit and overload protection via a built in circuit breaker.

**Option: MPC (Multiple Protocol Control) interface system**

Units shall have all the features listed above (either CXM or DXM2) and the control board will be supplied with a Multiple Protocol interface board. Available protocols are BACnet MS/TP, Modbus, or Johnson Controls N2. The choice of protocol shall be field selectable/changeable via the use of a simple selector switch. Protocol selection shall not require any additional programming or special external hardware or software tools. This will permit all units to be daisy chain connected by a 2-wire twisted pair shielded cable. The following points must be available at a central or remote computer location:

- a. Space temperature
- b. Leaving water temperature
- c. Discharge air temperature
- d. Command of space temperature setpoint
- e. Cooling status
- f. Heating status
- g. Low temperature sensor alarm

# HKV Large Series 60Hz Engineering Specifications - Page 8

- h. Low pressure sensor alarm
- i. High pressure switch alarm
- j. Condensate overflow alarm
- k. Hi/low voltage alarm
- l. Fan "ON/AUTO" position of space thermostat as specified above
- m. Unoccupied / occupied command
- n. Cooling command
- o. Heating command
- p. Fan "ON/AUTO" command
- q. Fault reset command
- r. Itemized fault code revealing reason for specific shutdown fault (any one of 7)

This option also provides the upgraded 75VA control transformer with load side short circuit and overload protection via a built in circuit breaker.

## FIELD INSTALLED OPTIONS

### Hose Kits:

All units 120,000 BTUH (35 kW) and below shall be connected with hoses. The hoses shall be 2 feet (61cm) long, braided stainless steel; fire rated hoses complete with adapters. Only fire rated hoses will be accepted.

### Valves:

The following valves are available and will be shipped loose:

- a. Ball valve; bronze material, standard port full flow design, FPT connections.
- b. Ball valve with memory stop and PT port.
- c. "Y" strainer with blowdown valve; bronze material, FPT connections.
- d. Motorized water valve; slow acting, 24v, FPT connections.

### Hose Kit Assemblies:

The following assemblies ship with the valves already assembled to the hose described:

- a. Supply and return hoses having ball valve with PT port.
- b. Supply hose having ball valve with PT port; return hose having automatic flow regulator valve with PT ports, and ball valve.
- c. Supply hose having "Y" strainer with blowdown valve, and ball valve with PT port; return hose having automatic flow regulator with PT ports, and ball valve.
- d. Supply hose having "Y" strainer with blowdown valve, and ball valve with PT port; return hose having ball valve with PT port.

### Thermostats:

The thermostat shall be a mechanical or electronic type thermostat as selected below with the described features:

- a. Single Stage Digital Auto or Manual Changeover  
Thermostat shall be a single-stage, digital, auto or manual changeover with HEAT-OFF-COOL-AUTO system switch and fan ON-AUTO switch. Thermostat shall have an LCD display with temperature and set-point(s) in °F or °C. The Thermostat shall provide permanent memory of set-point(s) without batteries. A fault LED shall be provided to display specific fault condition. Thermostat shall provide temperature display offset for custom applications.
- b. Multi-stage Digital Automatic Changeover  
Thermostat shall be multi-stage (2H/2C), manual or automatic changeover with HEAT-OFF-COOL-AUTO-EM HEAT system settings and fan ON-AUTO settings. Thermostat shall have an LCD display with temperature, set-point(s), mode, and status indication. The temperature indication shall be selectable for °F or °C. The thermostat shall provide permanent memory of

HKV Large Series 60Hz  
Engineering Specifications - Page 9

set-point(s) without batteries. A fault LED shall be provided to indicate specific fault condition(s). Thermostat shall provide temperature display offset for custom applications. Thermostat shall allow unit to provide better dehumidification with optional DXM2 controller by automatically using lower fan speed on stage 1 cooling (higher latent cooling) as main cooling mode, and automatically shifting to high speed fan on stage 2 cooling.

c. Multi-stage Manual Changeover Programmable 5/2 Day

Thermostat shall be 5 day/2 day programmable (with up to 4 setpoints per day), multi-stage (2H/1C), manual changeover with HEAT-OFF-COOL-EM HEAT system settings and fan ON-AUTO settings. Thermostat shall have an LCD display with temperature, setpoint(s), mode, and status indication. The temperature indication shall be selectable for ° F or ° C. The thermostat shall provide permanent memory of setpoint(s) without batteries. Thermostat shall provide convenient override feature to temporarily change setpoint.

d. Multi-stage Automatic or Manual Changeover Programmable 7 Day

Thermostat shall be 7 day programmable (with up to 4 setpoints per day), multi-stage (3H/2C), automatic or manual changeover with HEAT-OFF-COOL-AUTO-EM HEAT system settings and fan ON-AUTO settings. Thermostat shall have a blue backlit dot matrix LCD display with temperature, setpoints, mode, and status indication. The temperature indication shall be selectable for °F or °C. Time display shall be selectable for 12 or 24 hour clock. Fault identification shall be provided (when used with Comfort-Aire/Century CXM or DXM2 controls) to simplify troubleshooting by providing specific unit fault at the thermostat with red backlit LCD during unit lockout. The thermostat shall provide permanent memory of setpoints without batteries. Thermostat shall provide heating set-point range limit, cooling setpoint range limit, temperature display offset, keypad lockout, dead-band range setting, and inter-stage differential settings. Thermostat shall provide progressive recovery to anticipate time required to bring space temperature to the next programmed event. Thermostat shall provide an installer setup for configuring options and for setup of servicing contractor name and contact information. Thermostat shall allow the use of an accessory remote and/or outdoor temperature sensor (AST008). Thermostat navigation shall be accomplished via five buttons (up/down/right/left/select) with menu-driven selections for ease of use and programming.

e. Multi-stage Automatic or Manual Changeover Programmable 7 Day with Humidity Control

Thermostat shall be 7 day programmable (with up to 4 set points per day), multi-stage (3H/2C), automatic or manual changeover with HEAT-OFF-COOL-AUTO-EM HEAT system settings and fan ON-AUTO settings. Separate dehumidification and humidification set points shall be configurable for discreet outputs to a dehumidification option and/or an external humidifier. Installer configuration mode shall allow thermostat dehumidification mode to operate with ClimaDry® reheat or with ECM fan dehumidification mode via settings changes. Thermostat shall have a blue backlit dot matrix LCD display with temperature, relative humidity, setpoints, mode, and status indication. The temperature indication shall be selectable for °F or °C. Time display shall be selectable for 12 or 24 hour clock. Fault identification shall be provided (when used with Comfort-Aire/Century CXM or DXM2 controls) to simplify troubleshooting by providing specific unit fault at the thermostat with red backlit LCD during unit lockout. The thermostat shall provide permanent memory of setpoints without batteries. Thermostat shall provide heating set-point range limit, cooling set-point range limit, temperature display offset, keypad lockout, dead-band range setting, and inter-stage differential settings. Thermostat shall provide progressive recovery to anticipate time required to bring space temperature to the next programmed event. Thermostat shall provide an installer setup for configuring options and for setup of servicing contractor name and contact information. Thermostat shall allow the use of an accessory remote and/or outdoor temperature sensor (AST008). Thermostat navigation shall be accomplished via five buttons (up/down/right/left/select) with menu-driven selections for ease of use and programming.

**DDC Sensors:**

Comfort-Aire/Century wall mounted DDC sensor to monitor room temperature and interfaces with optional interface system described above. Several types as described below:

- a. Sensor only with no display (LON and MPC).
- b. Sensor with override (LON only).
- c. Sensor with setpoint adjustment and override (MPC only).
- d. Sensor with setpoint adjustment and override, LCD display, status/fault indication (LON and MPC)





# Revision History

Date:	Item:	Action:
9/16/19	Page 50-51	Updated HKV Engineering Specs w/ DXM2 Spec Language
	Page 46	Updated Diagram
	Page 22, 23	Updated to DXM2
	Page 6	Updated to New Decoder
	Page 3	Inserted iGate paragraph, Added "2" to DXM, Added "DXM2 Control" to Options
11/15/16	Document Design Updated	Updated
06/20/16	Page 4, 47	Unit feature
03/28/16	Page 47	Run test Engineering Specs. edit
09/25/15	Page 19 WPD Table	Updated
07/30/15	Page 19 WPD for MWV	Updated
06/16/14	Pages 4, 7, 38, 39, 52	Updated filter frame description
06/09/14	Find/Change text "rack" to "rail" - All	Updated
09/30/13	Edit Text - Page 50	Updated
04/15/13	EAT for ClimaDry® Option	Updated
12/11/12	Engineering Specifications Decoder Unit Features - Options	Updated
02/20/12	Engineering Specifications	Updated
01/24/12	HKV Series Nomenclature with ClimaDry® II Option	Updated
11/29/11	HKV240 Blower Performance Table	Updated
08/19/11	All	Removed 460 volt neutral wire with Climadry/internal pump
08/09/11	Unit Maximum Working Water Pressure	Updated to Reflect New Safeties
08/03/11	Engineering Specifications	Added Digital Night Setback with Pump Restart (DXM w/ ATP32U03/04)
06/01/11	Document	Incorporated ClimaDry® Information
05/02/11	ClimaDry® II Information	Added
04/07/11	Engineering Specifications NOTICE	Updated
02/11/11	Performance Data Selection Notes	Updated
01/03/11	Format - All Pages	Updated

Due to ongoing product improvements, specifications and dimensions are subject to change and correction without notice or incurring obligations. Determining the application and suitability for use of any product is the responsibility of the installer. Additionally, the installer is responsible for verifying dimensional data on the actual product prior to beginning any installation preparations.

Incentive and rebate programs have precise requirements as to product performance and certification. All products meet applicable regulations in effect on date of manufacture; however, certifications are not necessarily granted for the life of a product. Therefore, it is the responsibility of the applicant to determine whether a specific model qualifies for these incentive/rebate programs.



1900 Wellworth Ave., Jackson, MI 49203 • Ph. 517-787-2100 • [www.heatcontroller.com](http://www.heatcontroller.com)