



Installation, Operation & Maintenance

HKV Series

**Large Commercial Vertical Packaged
Heat Pump with R-410A HKV 084-300
60Hz - HFC-410A**

Table of Contents

| | |
|---|----|
| Model Nomenclature | 3 |
| General Information | 4 |
| HKV Physical Data | 6 |
| HKV084-150 Dimensional Data | 7 |
| HKV168-300 Dimensional Data | 8 |
| Installation | 9 |
| Piping Installation | 11 |
| Condensate Installation | 12 |
| Water-Loop Heat Pump Applications | 13 |
| Ground-Loop Heat Pump Applications | 14 |
| Ground-Water Heat Pump Applications | 16 |
| Water Quality Requirements | 16 |
| Electrical Data | 18 |
| Electrical - Power Wiring | 22 |
| Electrical - Low Voltage or MPC Control Operation | 23 |
| Controls - CXM2 and DXM2.5 | 24 |
| HKV Series Wiring Diagram Matrix | 25 |
| Blower Adjustment | 27 |
| Tensioning V-Belt Drives | 28 |
| Blower Sheave Information | 29 |
| Blower Performance | 30 |
| Unit Commissioning & Operating Conditions | 43 |
| Piping System Cleaning & Flushing | 44 |
| Unit & System Checkout | 45 |
| Unit Start Up Procedure | 46 |
| Start-up Log Sheet | 48 |
| Unit Operating Conditions | 49 |
| Preventive Maintenance | 50 |
| Functional Troubleshooting | 51 |
| Performance Troubleshooting | 52 |
| Troubleshooting Form | 53 |
| What's New | 54 |
| Revision History | 69 |

Model Nomenclature – General Overview

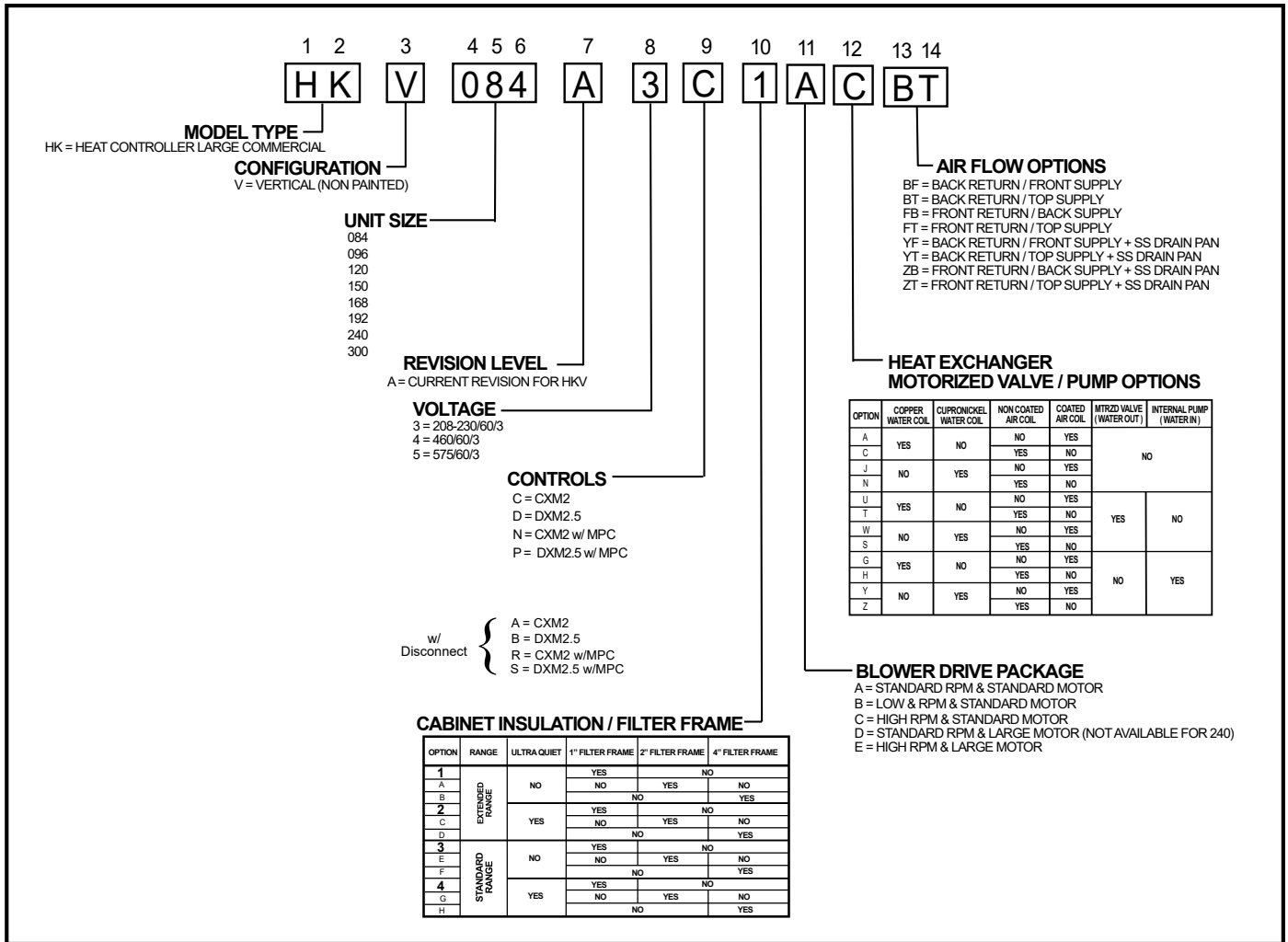

Note: Above model nomenclature is a general reference. Not all configurations are available on all models. Consult selection software for detailed information.

General Information

Safety

Warnings, cautions, and notices appear throughout this manual. Read these items carefully before attempting any installation, service, or troubleshooting of the equipment.

DANGER: Indicates an immediate hazardous situation, which if not avoided will result in death or serious injury. DANGER labels on unit access panels must be observed.

WARNING: Indicates a potentially hazardous situation, which if not avoided could result in death or serious injury.

CAUTION: Indicates a potentially hazardous situation or an unsafe practice, which if not avoided could result in minor or moderate injury or product or property damage.

NOTICE: Notification of installation, operation, or maintenance information, which is important, but which is not hazard-related.

WARNING!

WARNING! The EarthPure® Application and Service Manual should be read and understood before attempting to service refrigerant circuits with HFC-410A.

WARNING!

WARNING! To avoid the release of refrigerant into the atmosphere, the refrigerant circuit of this unit must be serviced only by technicians who meet local, state, and federal proficiency requirements.

CAUTION!

CAUTION! To avoid equipment damage, DO NOT use these units as a source of heating or cooling during the construction process. The mechanical components and filters can quickly become clogged with construction dirt and debris, which may cause system damage and void product warranty.

WARNING!

WARNING! The installation of water-source heat pumps and all associated components, parts, and accessories which make up the installation shall be in accordance with the regulations of ALL authorities having jurisdiction and MUST conform to all applicable codes. It is the responsibility of the installing contractor to determine and comply with ALL applicable codes and regulations.

WARNING!

WARNING! All refrigerant discharged from this unit must be recovered WITHOUT EXCEPTION. Technicians must follow industry accepted guidelines and all local, state, and federal statutes for the recovery and disposal of refrigerants. If a compressor is removed from this unit, refrigerant circuit oil will remain in the compressor. To avoid leakage of compressor oil, refrigerant lines of the compressor must be sealed after it is removed.

Inspection - Upon receipt of the equipment, carefully check the shipment against the bill of lading. Make sure all units have been received. Inspect the packaging of each unit, and inspect each unit for damage. Insure that the carrier makes proper notation of any shortages or damage on all copies of the freight bill and completes a common carrier inspection report. Concealed damage not discovered during unloading must be reported to the carrier within 15 days of receipt of shipment. If not filed within 15 days, the freight company can deny the claim without recourse. Note: It is the responsibility of the purchaser to file all necessary claims with the carrier. Notify your equipment supplier of all damage within fifteen (15) days of shipment.

Storage - Equipment should be stored in its original packaging in a clean, dry area. Store units in an upright position at all times.

Unit Protection - Cover units on the job site with either the original packaging or an equivalent protective covering. Cap the open ends of pipes stored on the job site. In areas where painting, plastering, and/or spraying has not been completed, all due precautions must be taken to avoid physical damage to the units and contamination by foreign material. Physical damage and contamination may prevent proper start-up and may result in cosHKVv equipment clean-up.

Examine all pipes, fittings, and valves before installing any of the system components. Remove any dirt or debris found in or on these components.

General Information, Cont'd.

Pre-Installation - Installation, Operation, and Maintenance instructions are provided with each unit. Horizontal equipment is designed for installation above false ceiling or in a ceiling plenum. Other unit configurations are typically installed in a mechanical room. The installation site chosen should include adequate service clearance around the unit. Before unit start-up, read all manuals and become familiar with the unit and its operation. Thoroughly check the system before operation.

Prepare units for installation as follows:

1. Compare the electrical data on the unit nameplate with ordering and shipping information to verify that the correct unit has been shipped.
2. Keep the cabinet covered with the original packaging until installation is complete and all plastering, painting, etc. is finished.
3. Verify refrigerant tubing is free of kinks or dents and that it does not touch other unit components.
4. Inspect all electrical connections. Connections must be clean and tight at the terminals.
5. Some airflow patterns and some control box locations are field convertible. Locate the conversion section of this IOM.

CAUTION!

CAUTION! All three phase scroll compressors must have direction of rotation verified at start-up. Verification is achieved by checking compressor Amp draw. Amp draw will be substantially lower compared to nameplate values. Additionally, reverse rotation results in an elevated sound level compared to correct rotation. Reverse rotation will result in compressor internal overload trip within several minutes. Verify compressor type before proceeding.

CAUTION!

CAUTION! DO NOT store or install units in corrosive environments or in locations subject to temperature or humidity extremes (e.g., attics, garages, rooftops, etc.). Corrosive conditions and high temperature or humidity can significantly reduce performance, reliability, and service life. Always move and store units in an upright position. Tilting units on their sides will cause equipment damage.

CAUTION!

CAUTION! CUT HAZARD - Failure to follow this caution may result in personal injury. Sheet metal parts may have sharp edges or burrs. Use care and wear appropriate protective clothing, safety glasses and gloves when handling parts and servicing heat pumps.

HKV Physical Data

| Model | 084 | 096 | 120 | 150 | 168 | 192 | 240 | 300 |
|--|--------------------------------|------------|-------------|-----------------------|--------------------------------|------------|---------------|-----------------------|
| Compressor Quantity | Scroll (1) | | | | Scroll (2) | | | |
| Factory Charge HFC-410a (oz) [kg] per circuit | 140 [3.97] | 156 [4.42] | 224 [6.35] | 248 [7.03] | 140 [3.97] | 156 [4.42] | 224 [6.35] | 248 [7.03] |
| Blower Motor | | | | | | | | |
| Blower Motor Quantity | 1 | | | | | | | |
| Standard Motor (hp) [kW] | 1.0 [.75] | 1.5 [1.12] | 2 [1.49] | 3 [2.24] | 2 [1.49] | 3 [2.24] | 5 [3.73] | 5 [3.73] |
| Large Motor (hp) [kW] | 1.5 [1.12] | 2.0 [1.49] | 3 [2.24] | 5 [3.73] | 3 [2.24] | 5 [3.73] | 7.5 [5.60] | 7.5 [5.60] |
| Blower | | | | | | | | |
| No. of Blowers | 1 | | | | 2 | | | |
| Blower Wheel Size D x W (in) [cm] | 15 x 11 [38.1 x 38.1] | | | 15 x 15 [38.1 x 38.1] | 15 x 11 [38.1 x 38.1] | | | 15 x 15 [38.1 x 38.1] |
| Water Connection Size | | | | | | | | |
| FPT (in) [mm] | 1-1/2" [38.1] | | | 2" [50.8] | | | 2-1/2" [63.5] | |
| Coax Volume | | | | | | | | |
| Volume (US Gallons) [liters] | 2.19 [8.28] | | 2.48 [9.37] | 3.46 [13.11] | 4.83 [18.29] | | 6.36 [24.08] | 7.39 [27.98] |
| Condensate Connection Size | | | | | | | | |
| FPT (in) [mm] | 1" [25.4] | | | | | | | |
| Air Coil Data | | | | | | | | |
| Air Coil Dimensions H x W (in) [cm] | 36 x 48 [91.4 x 121.9] | | | | 2 - 36 x 48 [91.4 x 121.9] | | | |
| Air Coil Total Face Area (ft²) [m²] | 12 [1.11] | | | | 24 [2.22] | | | |
| Miscellaneous Data | | | | | | | | |
| Filter Standard - 1" [25.4mm] Throwaway (qty) (in) [cm] | (QTY.4) 18 x 25 [45.74 x 63.5] | | | | (QTY.8) 18 x 25 [45.74 x 63.5] | | | |
| Weight - Operating (lbs) [kg] | 880 [399] | | 930 [422] | 960 [435] | 1600 [725] | | 1665 [755] | 1695 [769] |
| Weight - Packaged (lbs) [kg] | 895 [406] | | 945 [429] | 975 [442] | 1630 [739] | | 1695 [769] | 1725 [782] |

All units have grommet compressor mountings, and 1/2" & 1-3/4" electrical knockouts.

| Unit Maximum Water Working Pressure | |
|--------------------------------------|-------------------------|
| Options | Max Pressure PSIG [kPa] |
| Base Unit | 300 [2,068] |
| Motorized Water Valve | 300 [2,068] |
| Internal Secondary Pump or ClimaDry® | 145 [999] |

Use the lowest maximum pressure rating when multiple options are combined.

HkV084-150 Dimensional Data

ALL CONFIGURATIONS REQUIRE SERVICE ACCESS AREA DESCRIBED IN NOTES 7, 8, 9, AND 10.

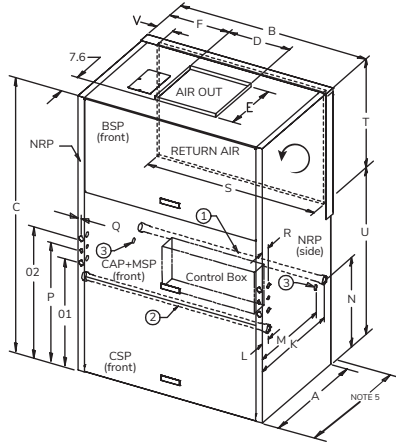

REAR RETURN TOP DISCHARGE (RR/TD)

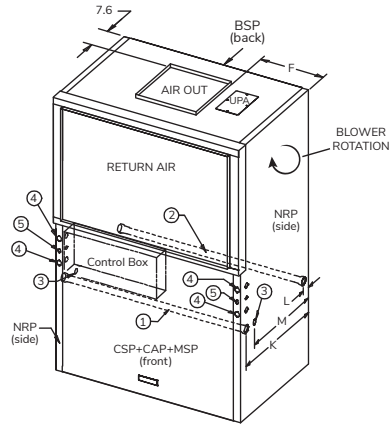

FRONT RETURN TOP DISCHARGE (FR/TD)

| LEGEND | 084-120 | 150 |
|--|------------------|--------|
| ① Water Inlet (See Note 2) | 1-1/2" FPT | 2" FPT |
| ② Water Outlet (See Note 2) | 1-1/2" FPT | 2" FPT |
| ③ Condensate Drain (See Note 3) | 1" FPT | |
| ④ High Voltage Access (See Note 4) | 1-3/8" [3.49 CM] | |
| ⑤ Low Voltage Access (See Note 4) | 7/8" [2.2 CM] | |
| BSP - Blower Service Panel CAP - Control Access Panel CSP - Compressor Access Panel MSP - Motor Service Panel NRP - Non Removable Panel UPA - Upper Pulley Access | | |

NOTES:

- All dimensions in inches (cm)
- Water inlet and water outlet connections are available on either side (left or right) of the unit. Installer must plug water inlet/outlet not being connected to.
- Condensate drain is available on either side (left or right) of unit. Drain hose and drain connection will be tied inside the unit. Installer will untie the drain hose, form trap, and connect to the condensate drain hole of installer's choice.
- Electrical access is available on either side (left or right) of unit and is also available in the front on the left or right side of the unit.
- Overall Depth - Add 3.12"(8 cm) for 1"(2.5 cm) or 2"(5 cm) Filter Frame; 5.12" for 4" Filter Frame and for FD, RD additional 1.06"(2.7cm) for supply air duct flange.
- Overall cabinet height dimension does not include duct flange when in top discharge configuration.
- While access to all removable panels may not be required, installer should take care to comply with all building codes and allow adequate clearance for future field service.
- Units require 3 feet (91 cm) clearance for water connections, CAP, CSP, MSP and BSP service access.
- Side service access must be 2 feet (9.4 cm) on any side that connections are made. If no connections are made on a side then service access can be 6 inches(1.5 cm) minimum.
- Filter removal is from bottom of frame, allow 2 feet (9.4 cm) access for servicing.

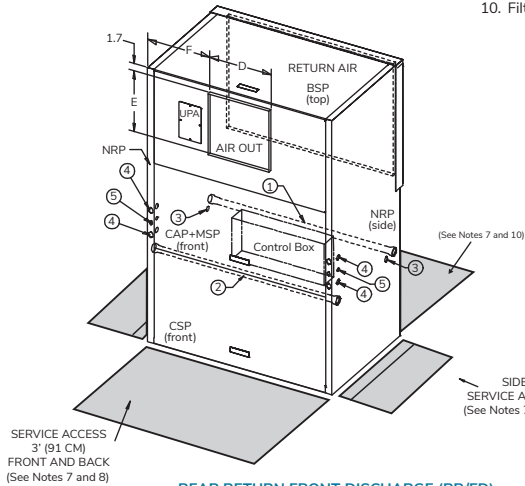

REAR RETURN FRONT DISCHARGE (RR/FD)

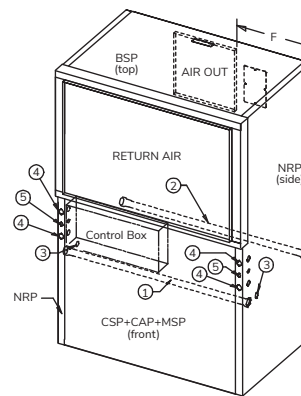

FRONT RETURN REAR DISCHARGE (FR/RD)

| Model | Overall Cabinet | | | Discharge Connections Duct Flange | | | Water Connections | | | | Electrical Knockouts | | | | | Return Air Connections Using Return Air Opening | | | | |
|---------|-----------------|--------------|---------------|-----------------------------------|--------------|--------------|-------------------|----------------|--------------|--------------|----------------------|--------------|--------------|--------------|------------|---|---------------|--------------|---------------|------------|
| | A | B | C | D | E | F | K | L | M | N | O1 | O2 | P | Q | R | S | T | U | V | |
| | Depth Note 5 | Width | Height Note 6 | Supply Width | Supply Depth | | 1 Water Inlet | 2 Water Outlet | 3 Condensate | | | | | | | Return Depth | Return Height | | | |
| 084-120 | in. cm. | 34.0 86.4 | 53.1 134.9 | 79.0 200.7 | 17.5 44.5 | 17.6 44.6 | 17.8 45.1 | 31.0 78.7 | 3.0 7.6 | 27.0 68.6 | 25.6 65.1 | 31.0 78.7 | 38.0 96.4 | 34.6 87.7 | 1.0 2.5 | 3.0 7.6 | 48.0 121.9 | 32.4 82.2 | 44.6 113.3 | 2.7 6.9 |
| 150 | in. cm. | 34.0 86.4 | 53.1 134.9 | 79.0 200.7 | 21.4 54.4 | 17.6 44.6 | 17.8 45.1 | 31.0 78.7 | 3.0 7.6 | 27.0 68.6 | 25.6 65.1 | 31.0 78.7 | 38.0 96.4 | 34.6 87.7 | 1.0 2.5 | 3.0 7.6 | 48.0 121.9 | 32.4 82.2 | 44.6 113.3 | 2.7 6.9 |

HKV168-300 Dimensional Data

ALL CONFIGURATIONS REQUIRE SERVICE ACCESS AREA DESCRIBED IN NOTES 7, 8, 9, AND 10.

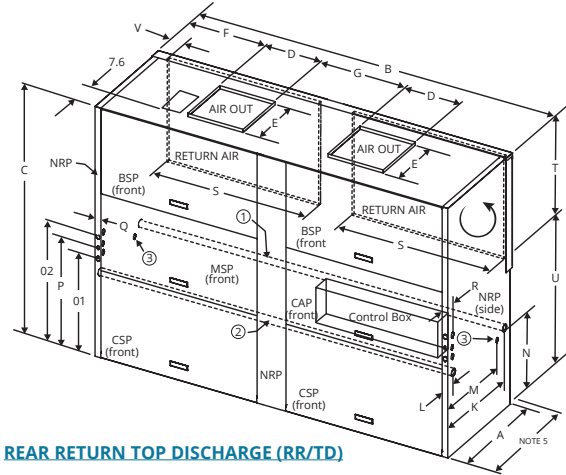

REAR RETURN TOP DISCHARGE (RR/TD)

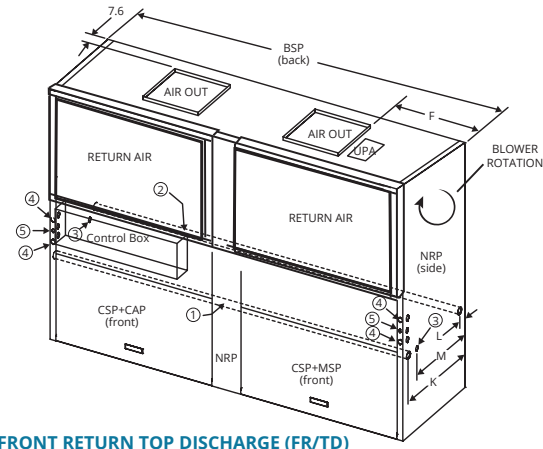

FRONT RETURN TOP DISCHARGE (FR/TD)

| LEGEND | 168-240 | 300 |
|--|------------------|------------|
| 1. Water inlet (see note 2) | 2" FPT | 2 1/2" FPT |
| 2. Water outlet (see note 2) | 2" FPT | 2 1/2" FPT |
| 3. Condensate drain (see note 3) | 1" FPT | |
| 4. High voltage access (see note 4) | 1 3/8" (3.49 cm) | |
| 5. Low voltage access (see note 4) | 7/8" (2.2 cm) | |
| BSP - Blower Service Panel CAP - Control Access Panel CSP - Compressor Access Panel MSP - Motor Service Panel NRP - Non Removable Panel UPA - Upper Pulley Access | | |

NOTES:

- All dimensions in inches (cm)
- Water inlet and water outlet connections are available on either side (left or right) of the unit. Installer must plug water inlet/outlet not being connected to.
- Condensate drain is available on either side (left or right) of unit. Drain hose and drain connection will be tied inside the unit. Installer will untie the drain hose, form trap, and connect to the condensate drain hole of installer's choice.
- Electrical access is available on either side (left or right) of unit and is also available in the front on the left or right side of the unit.
- Overall Depth - Add 3.12" (8 cm) for 1" (2.5 cm) or 2" (5 cm) Filter Frame; 5.12" for 4" Filter Frame and for FD, RD additional 1.06" (2.7 cm) for supply air duct flange.
- Overall cabinet height dimension does not include duct flange when in top discharge configuration.
- While access to all removable panels may not be required, installer should take care to comply with all building codes and allow adequate clearance for future field service.
- Units require 3 feet (91 cm) clearance for water connections, CAP, CSP, MSP and BSP service access.
- Side service access must be 2 feet (9.4 cm) on any side that connections are made. If no connections are made on a side then service access can be 6 inches (1.5 cm) minimum.
- Filter removal is from bottom of frame, allow 2 feet (9.4 cm) access for servicing.

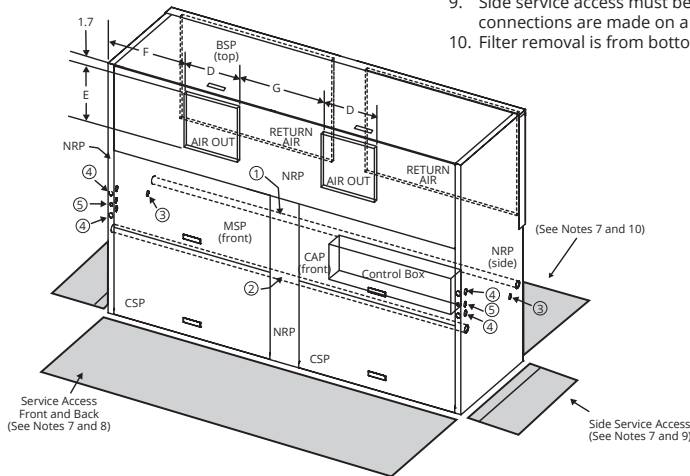

REAR RETURN FRONT DISCHARGE (RR/FD)

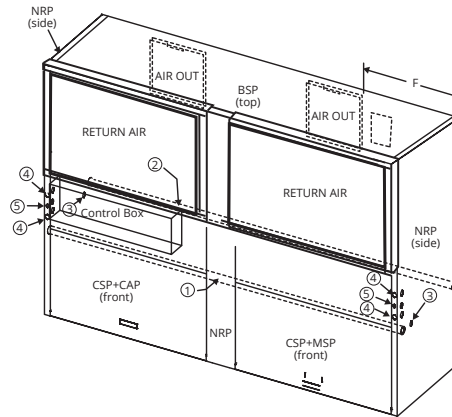

FRONT RETURN REAR DISCHARGE (FR/RD)

| Model | Overall Cabinet | | | Discharge Connections Duct Flange | | | | Water Connections | | | | Electrical Knockouts | | | | Return Air Connections Using Return Air Opening | | | | |
|---------|-----------------|-------|---------------|-----------------------------------|--------------|------|------|-------------------|----------------|--------------|------|----------------------|------|------|------|---|--------------|---------------|------|-------|
| | A | B | C | D | E | F | G | K | L | M | N | O1 | O2 | P | Q | R | S | T | U | V |
| | Depth Note 5 | Width | Height Note 6 | Supply Width | Supply Depth | | | 1 Water Inlet | 2 Water Outlet | 3 Condensate | | | | | | | Return Depth | Return Height | | |
| 168-240 | in. cm. | 34.0 | 106.7 | 79.0 | 17.5 | 17.6 | 17.8 | 31.0 | 3.0 | 27.0 | 25.6 | 31.0 | 38.0 | 34.6 | 1.0 | 3.0 | 48.0 | 32.4 | 44.6 | 2.7 |
| | | 86.4 | 270.9 | 200.7 | 44.5 | 44.6 | 45.1 | 79.4 | 78.7 | 7.6 | 68.6 | 65.1 | 78.7 | 96.4 | 87.8 | 2.5 | 7.6 | 121.9 | 82.2 | 113.3 |
| 300 | in. cm. | 34.0 | 106.7 | 79.0 | 21.4 | 17.6 | 17.8 | 31.0 | 3.0 | 27.0 | 25.6 | 31.0 | 38.0 | 34.6 | 1.0 | 3.0 | 48.0 | 32.4 | 44.6 | 2.7 |
| | | 86.4 | 270.9 | 200.7 | 54.4 | 44.6 | 45.1 | 59.4 | 78.7 | 7.6 | 68.6 | 65.1 | 78.7 | 96.4 | 87.8 | 2.5 | 7.6 | 121.9 | 82.2 | 113.3 |

Installation

Figure 1: Typical Vertical Installation

Rear Return/Top Discharge shown

Refer to Dimensional Data pages for other arrangements & dimensions

Ductwork not shown.

All components external of unit are field supplied.

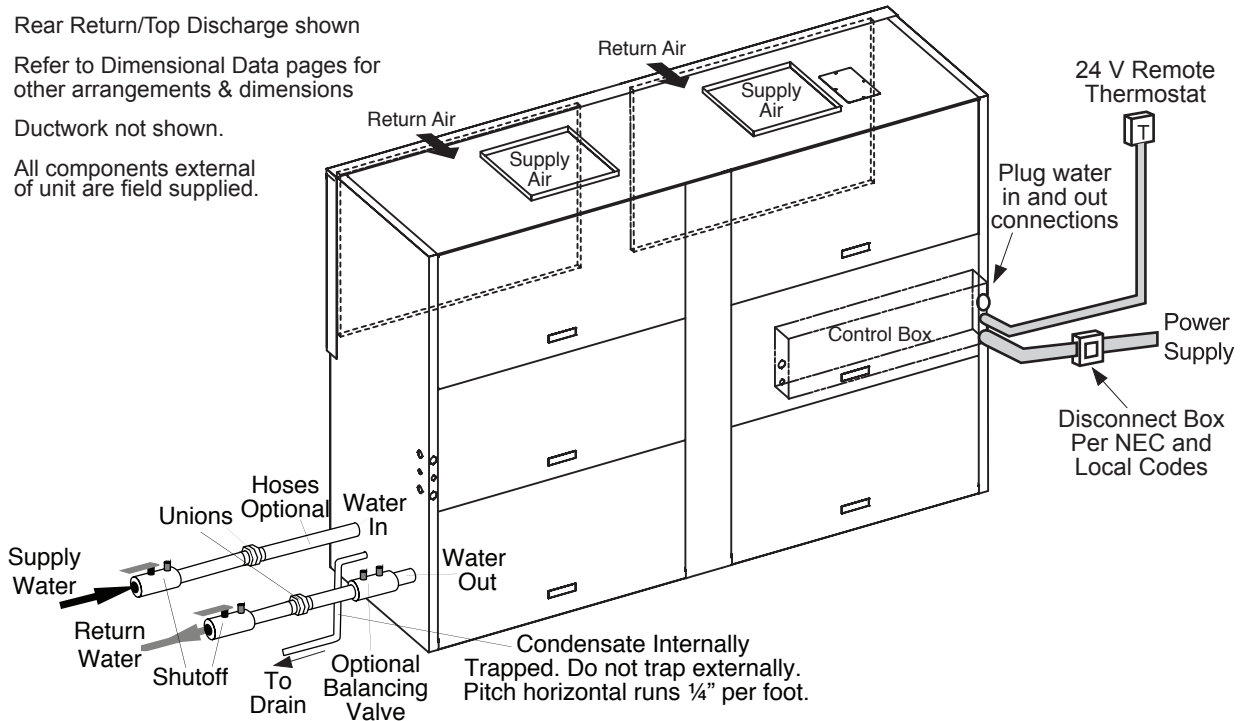

Vertical Location and Access

HKV units are not designed for outdoor installation. Locate the unit in an indoor area that allows enough space for installation and for service personnel to perform typical maintenance or repairs. HKV units are typically installed in a floor level closet or in a small mechanical room. Refer to Figure 2b for an illustration of a typical installation. Install units with adequate clearance to allow maintenance and servicing. Conform to the following guidelines when selecting unit location:

- Provide adequate clearance for filter replacement and drain pan cleaning. DO NOT block filter access with piping, conduit or other materials. Refer to submittal drawing for Vertical Unit Dimensions.
- Provide access for fan and fan motor maintenance and for servicing of the compressor and coils without removal of the unit.
- Provide an unobstructed path to the unit within the closet or mechanical room to enable removal of the unit if necessary.
- Provide access to water valves and fittings, and screwdriver access to the unit side panels, discharge collar and all electrical connections

Duct System Design & Installation Guidelines

The following application guidelines must be used when installing HKV units. Failure to follow these guidelines could result in unsatisfactory unit performance and/or premature failure of some unit components. Heat Controller will not warrant, or accept responsibility for products which fail, have defects, damage or insufficient performance as a result of improper application.

- The duct system must be sized to handle the airflow quietly and must not exceed the maximum allowable External Static Pressure. To maximize sound attenuation metal supply and return ducts should include internal insulation or be of duct board construction for the first 10 feet or end of first full-sized elbow.
- Install a flexible connector in all supply and return air ducts close to the unit to inhibit sound transfer to the ducts.
- Do not install uninsulated duct in an unconditioned space. The unit performance will be adversely affected and damage from condensate can occur.

- On units with multiple fan outlets a “pair of pants” duct connection must be used for proper air balance and distribution and to prevent fan oscillation.
- Include at least one 90-degree turn in supply air ducts to reduce noise transmission.
- Existing ducts must be checked to ensure proper size and configuration prior to installation of any replacement unit. Also inspect for and repair all air leaks in existing ducts.
- Units may only be connected to a dedicated duct system. Consult the factory BEFORE connecting multiple units to a common duct system.
- Never connect a unit to a duct system with automatic or modulating dampers, VAV boxes, etc. in the supply air system. Never allow a situation where the total unit CFM can drop below the minimum required for proper unit operation.
- Never connect a bypass damper from the supply air duct to the return air duct. Never allow the return air temperature to drop below the minimum allowable normal temperature for proper unit operation.
- Do not use HKV units for 100% outdoor air treatment. Do not add hot-gas-bypass to “convert” a unit for outdoor air treatment. Always use a dedicated outdoor air unit for outdoor air treatment.
- Do not exceed 10% of the total unit CFM with untreated outdoor air. Mixed air entering unit must be less than 95/75F in cooling mode and greater than 60F in heating mode.

Piping Installation

Installation of Supply and Return Piping

Follow these piping guidelines.

1. Install a drain valve at the base of each supply and return riser to facilitate system flushing.
2. Install shut-off / balancing valves and unions at each unit to permit unit removal for servicing.
3. Place strainers at the inlet of each system circulating pump.
4. Select the proper hose length to allow slack between connection points. Hoses may vary in length by +2% to -4% under pressure.
5. Refer to Table 1. Do not exceed the minimum bend radius for the hose selected. Exceeding the minimum bend radius may cause the hose to collapse which reduces water flow rate. Install an angle adapter to avoid sharp bends in the hose when the radius falls below the required minimum.

⚠ CAUTION! ⚠

CAUTION! Piping must comply with all applicable codes.

Table 1: Metal Hose Minimum Bend Radii

| Hoses in Inches | Minimum Bend Radius |
|-----------------|---------------------|
| 1" [25.4mm] | 5.5" [140mm] |
| 1.25" [31.8mm] | 7.0" [178mm] |
| 1.5" [38.1mm] | 8.5" [216mm] |

Insulation is not required on loop water piping except where the piping runs through unheated areas or outside the building or when the loop water temperature is below the minimum expected dew point of the pipe ambient.

Insulation is required if loop water temperature drops below the dew point.

Pipe joint compound is not necessary when Teflon threaded tape is pre-applied to hose assemblies or when flared-end connections are used. If pipe joint compound is preferred, use compound only in small amounts on the male pipe threads of the fitting adapters. Prevent sealant from reaching the flared surfaces of the joint.

⚠ WARNING! ⚠

WARNING! Polyolester Oil, commonly known as POE oil, is a synthetic oil used in many refrigeration systems including those with HFC-410A refrigerant. POE oil, if it ever comes in contact with PVC or CPVC piping, may cause failure of the PVC/CPVC. PVC/CPVC piping should never be used as supply or return water piping with water source heat pump products containing HFC-410A as system failures and property damage may result.

⚠ WARNING! ⚠

WARNING! Do not bend or kink supply lines or hoses.

⚠ CAUTION! ⚠

CAUTION! Corrosive system water requires corrosion resistant fittings and hoses and possibly water treatment.

Figure 2: Supply/Return Hose Kit

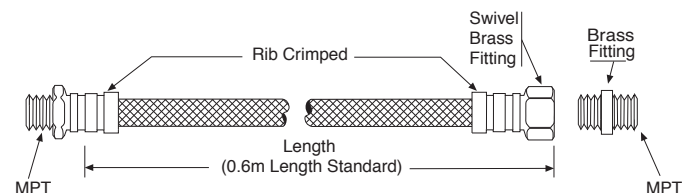

Note: When antifreeze is used in the loop, assure that it is compatible with Teflon tape or pipe joint compound employed.

Maximum allowable torque for brass fittings is 30 foot-pounds [41 N-m]. If a torque wrench is not available, tighten finger-tight plus one quarter turn. Tighten steel fittings as necessary.

Optional pressure-rated hose assemblies designed specifically for use with Heat Controller units are available. Similar hoses can be obtained from alternate suppliers. Supply and return hoses are fitted with swivel-joint fittings at one end to prevent kinking during installation.

Refer to Figure 2 for an illustration of a Supply/Return Hose Kit. External Pipe Thread (MPT) adapters secure hose assemblies to the unit and risers. Install hose assemblies properly and check them regularly to avoid system failure and reduced service life.

Condensate Installation

Condensate Piping - HKV - Remove KO on side that drain will be connected. Remove access panels. Inside of unit, untie and uncoil drain hose. Form trap in hose, make sure hose is not kinked or deformed. Connect plate assembly to side frame with 2 screws.

Outside of unit, connect 1" MPT fitting to plate assembly. Run line to building drain. Horizontal runs must be pitched $\frac{1}{4}$ " per foot (10 mm per 46 cm) toward drain. Do not trap externally.

Figure 3 illustrates a typical trap and vent used with HKV series equipment.

Figure 3: HKV

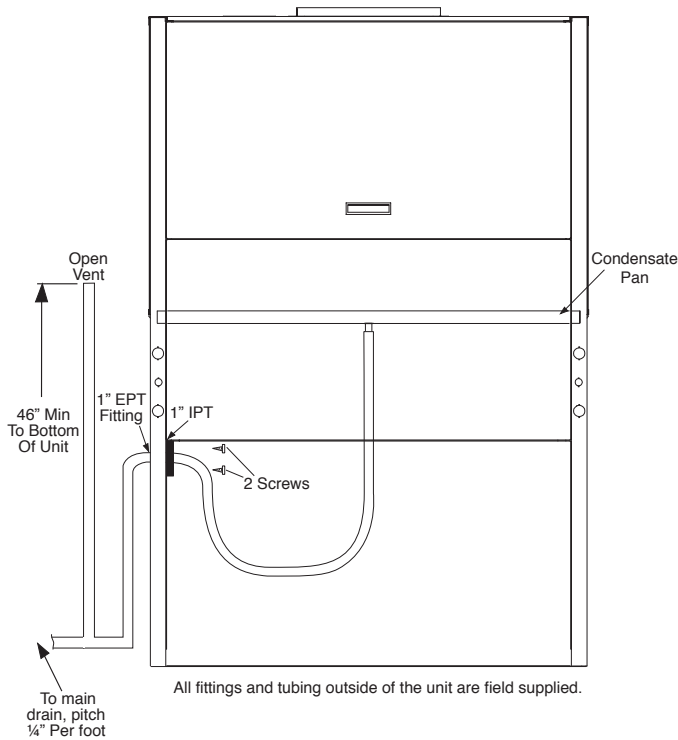

Each unit must be installed with its own individual line to the building main condensate drain line or riser. Provide a means to flush or blow out the condensate line. DO NOT install units with a common trap and or vent. Always vent the condensate line when dirt or air can collect in the line or a long horizontal drain line is required. Also vent when large units are working against higher external static pressure than other units connected to the same condensate main since this may cause poor drainage for all units on the line. WHEN A VENT IS INSTALLED IN THE DRAIN LINE, IT MUST BE LOCATED AFTER THE TRAP IN THE DIRECTION OF THE CONDENSATE FLOW and opening 46" (117 cm) minimum from bottom of unit. (Vent per code)

! WARNING! !

WARNING! Ensure condensate line is pitched toward drain $\frac{1}{4}$ " per foot [10mm per 46cm] of run.

Drain main or riser must be sized for all units connected to it.

| Pipe Size | Connected Tons | Connected kW |
|---------------|----------------|--------------|
| 3/4" [19mm] | <4 | <14 |
| 1" [25mm] | <6 | <21 |
| 1-1/4" [32mm] | <30 | <105 |
| 1-1/2" [38mm] | <50 | <175 |
| 2" [51mm] | <150 | <527 |
| 3" [76mm] | <300 | <1055 |
| 4" [102mm] | <500 | <1758 |

*** Make sure all connections are secure and water tight.**

After drain is connected to main and all drain connections are secure and water tight, pour 1 gallon of water into condensate pan. Water should drain out freely. Repair any leaks.

Water-Loop Heat Pump Applications

Commercial systems typically include a number of units plumbed to a common piping system. Any unit plumbing maintenance work can introduce air into the piping system, therefore air elimination equipment is a major portion of the mechanical room plumbing. In piping systems expected to utilize water temperatures below 50°F [10°C], 1/2" [13mm] closed cell insulation is required on all piping surfaces to eliminate condensation. Metal to plastic threaded joints should never be employed due to their tendency to leak over time. Teflon tape thread sealant is recommended to minimize internal fouling of the heat exchanger. Do not overtighten connections and route piping so as not to interfere with service or maintenance access. Hose kits are available from Heat Controller in different configurations as shown in Figure 4 for connection between the HKV Series and the piping system. The hose kits include shut off valves, P/T plugs for performance measurement, high pressure stainless steel braid hose, "Y" type strainer with blowdown valve, and "J" type swivel connection. Balancing valves to facilitate the balancing of the system, and an external low pressure drop solenoid valve for use in variable speed pumping systems, may also be included in the hose kit. The piping system should be flushed to remove dirt, piping chips, and other foreign material prior to operation. See Piping System Cleaning and Flushing Procedures.

The flow rate is usually set between 2.25 and 3.5 gpm per ton [2.9 l/m and 4.5 l/m per kW] of cooling capacity. Heat Controller recommends 2.5 gpm per ton [3.2 l/m per kW] for most applications of water loop heat pumps. To insure proper maintenance and servicing, P/T ports are imperative for temperature and flow verification, as well as performance checks.

Cooling Tower/Boiler Systems typically utilize a common loop maintained 60-90°F [16-32°C]. The use of a closed circuit evaporative cooling tower with a secondary heat exchanger between the tower and the water loop is recommended. If an open type cooling tower is used continuously, chemical treatment and filtering will be necessary.

Low Water Temperature Cutout Setting -

CXM2 or DXM2.5 Control: When an antifreeze is selected, the LT1 jumper (JW3) should be clipped to select the low temperature (Antifreeze 13°F [-10.6°C]) setpoint to avoid nuisance faults. See Low Water Temperature Cutout Selection. NOTE THAT THE EXTENDED RANGE OPTION SHOULD BE SELECTED WHEN LOOP CONDITIONS ARE EXPECTED TO DROP BELOW 60°F [16°C].

Figure 4: Typical Water Loop Application

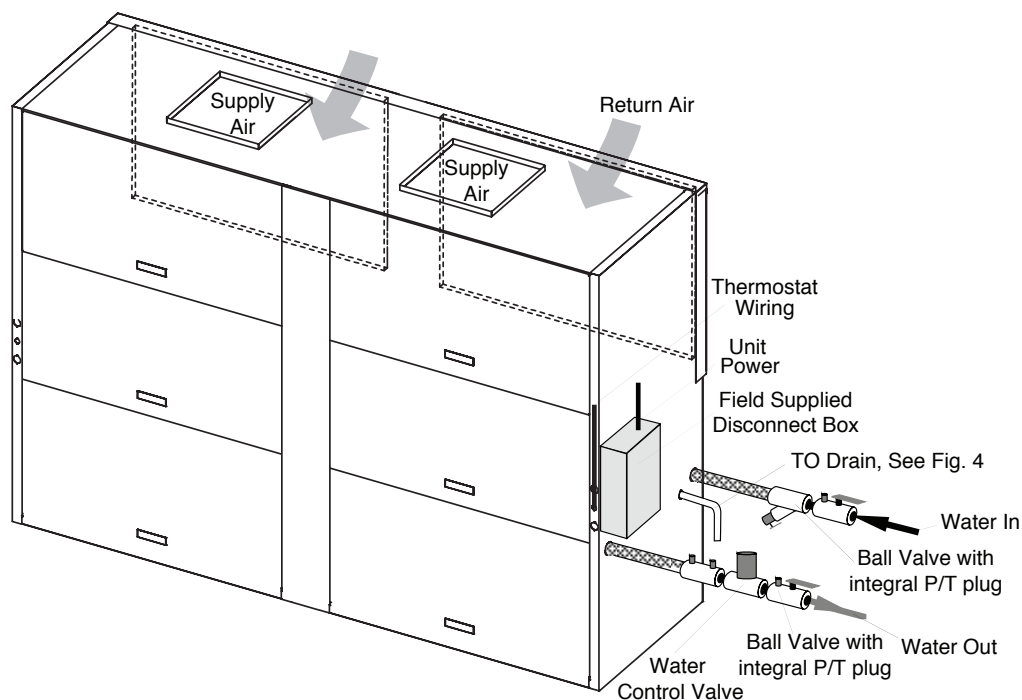

Ground-Loop Heat Pump Applications

⚠ CAUTION! ⚠

CAUTION! The following instructions represent industry accepted installation practices for Closed Loop Earth Coupled Heat Pump Systems. They are provided to assist the contractor in installing trouble free ground loops. These instructions are recommended only. State and Local Codes **MUST** be followed and installation **MUST** conform to ALL applicable Codes. It is the responsibility of the Installing contractor to determine and comply with ALL applicable Codes and Regulations.

Pre-Installation - Prior to installation, locate and mark all existing underground utilities, piping, etc. Install loops for new construction before sidewalks, patios, driveways, and other construction has begun. During construction, accurately mark all ground loop piping on the plot plan as an aid in avoiding potential future damage to the installation.

Piping Installation - The typical closed loop ground source system is shown in Figure 5. All earth loop piping materials should be limited to only polyethylene fusion for inground sections of the loop. Galvanized or steel fitting should not be used at any time due to their tendency to corrode. All plastic to metal threaded fittings should be avoided due to their potential to leak in earth coupled applications and a flanged fitting substituted. P/T plugs should be used so that flow can be measured using the pressure drop of the unit heat exchanger in lieu of other flow measurement means. Earth loop temperatures can range between 25 to 110°F (-4 to 43°C), and 2.25 to 3 gpm of flow per ton (2.41 l/m to 3.23 l/m per kW) of cooling capacity is recommended in these applications. Upon completion of the ground loop piping, pressure test the loop to assure a leak free system.

Flushing the Earth Loop - Upon completion of system installation and testing, flush the system to remove all foreign objects and purge to remove all air.

Figure 5: Typical Earth Loop Application

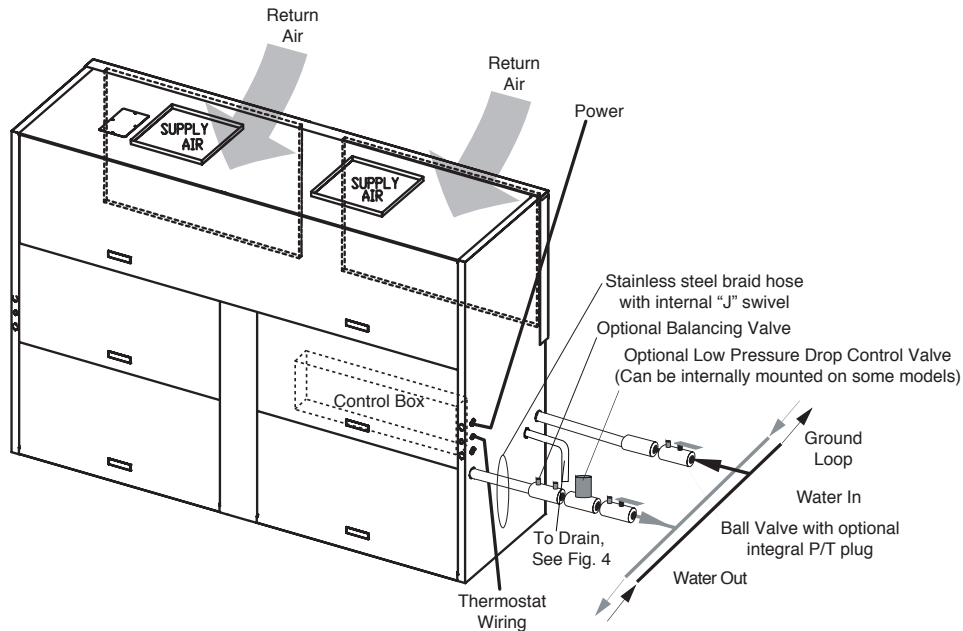

Table 2: Antifreeze Percentages by Volume

| Type | Minimum Temperature for Low Temperature Protection | | | |
|--------------------------------------|--|---------------|---------------|---------------|
| | 10°F [-12.2°C] | 15°F [-9.4°C] | 20°F [-6.7°C] | 25°F [-3.9°C] |
| Methanol | 25% | 21% | 16% | 10% |
| 100% USP food grade Propylene Glycol | 38% | 25% | 22% | 15% |
| Ethanol* | 29% | 25% | 20% | 14% |

* Must not be denatured with any petroleum based product



Antifreeze - In areas where minimum entering loop temperatures drop below 40°F (5°C) or where piping will be routed through areas subject to freezing, anti-freeze is needed. Alcohols and glycols are commonly used as antifreezes, however your local sales manager should be consulted for the antifreeze best suited to your area. Low temperature protection should be maintained to 15°F (9°C) below the lowest expected entering loop temperature. For example, if 30°F (-1°C) is the minimum expected entering loop temperature, the leaving loop temperature would be 25 to 22°F (-4 to -6°C) and low temperature protection should be at 15°F (-10°C) e.g. 30°F - 15°F = 15°F (-1°C - 9°C = -10°C). All alcohols should be premixed and pumped from a reservoir outside of the building when possible or introduced under water level to prevent fuming. Initially calculate the total volume of fluid in the piping system. Then use the percentage by volume shown in Table 2 for the amount of antifreeze. Antifreeze concentration should be checked from a well mixed sample using a hydrometer to measure specific gravity.

Low Water Temperature Cut-Out Setting -

CXM2 or DXM2.5 Control: When an antifreeze is selected, the LT1 jumper (JW3) should be clipped to select the low temperature (Antifreeze 10°F [-12.2°C]) setpoint to avoid nuisance faults.

Ground-Water Heat Pump Applications

Shut off valves should be included in case of servicing. Boiler drains or other valves should be 'tee'd' into the line to allow acid flushing of just the heat exchanger. Pressure temperature plugs should be used so that flow and temperature can be measured. Supply and return water piping materials should be limited to copper, PE, or similar material. PVC or CPVC should never be used as they are incompatible with the POE oils used in HFC-410A products and piping system failure and property damage may result.

 **WARNING!** 

WARNING! Polyolester Oil, commonly known as POE oil, is a synthetic oil used in many refrigeration systems including those with HFC-410A refrigerant. POE oil, if it ever comes in contact with PVC or CPVC piping, may cause failure of the PVC/CPVC. PVC/CPVC piping should never be used as supply or return water piping with water source heat pump products containing HFC-410A as system failures and property damage may result.

Water quantity should be plentiful and of good quality. Consult Table 3 for water quality requirements. The unit can be ordered with either a copper or cupro-nickel water heat exchanger. Consult Table 3 for recommendations. Copper is recommended for closed loop systems and open loop ground water systems that are not high in mineral content or

corrosiveness. In conditions anticipating heavy scale formation or in brackish water, a cupro-nickel heat exchanger is recommended. In ground water situations where scaling could be heavy or where biological growth such as iron bacteria will be present, a closed loop system is recommended. Heat exchanger coils may over time lose heat exchange capabilities due to a build up of mineral deposits inside. These can be cleaned only by a qualified service mechanic as acid and special pumping equipment are required. Desuperheater coils can likewise become scaled and possibly plugged. In areas with extremely hard water, the owner should be informed that the heat exchanger may require occasional acid flushing.

Expansion Tank and Pump - Use a closed, bladder-type expansion tank to minimize mineral formation due to air exposure. The expansion tank should be sized to handle at least one minute run time of the pump to prevent premature pump failure using its drawdown capacity rating. Discharge water from the unit is not contaminated in any manner and can be disposed of in various ways, depending on local building codes, i.e. recharge well, storm sewer, drain field, adjacent stream or pond, etc. Most local codes forbid the use of sanitary sewer for disposal. Consult your local building and zoning department to assure compliance in your area.

Water Control Valve - Note the placement of the water control valve. Always maintain water pressure in the heat exchanger by placing water control valves at the outlet of the unit to prevent mineral precipitation during the off- cycle. Pilot operated slow closing valves are recommended to reduce water hammer. If water hammer persists, a mini-expansion tank can be mounted on the piping to help absorb the excess hammer shock. Insure that the total 'VA' draw of the valve can be supplied by the unit transformer. For instance, the slow closing valve can draw up to 35VA. This can overload smaller 40 or 50 VA transformers depending on the other controls employed. A typical pilot operated solenoid valve draws approximately 15VA.

Flow Regulation - Flow regulation can be accomplished by two methods. Most water control valves have a built in flow adjustment. By measuring the pressure drop through the unit heat exchanger, flow rate can be determined and compared to Table 7. Since the pressure is constantly varying, two pressure gauges might be needed. Simply adjust the water control valve until the desired flow of 1.5 to 2 gpm per ton (2.0 to 2.6 l/m per kW) is achieved. Secondly, a flow control device may be installed. The devices are typically an orifice of plastic material that are designed to allow a specified flow rate. These are mounted on the outlet of the water control valve. On occasion, these valves can produce a velocity noise that can be reduced by applying some back pressure. This is accomplished by slightly closing the leaving isolation valve of the well water setup.

Ground-Water Heat Pump Applications



CAUTION! Low Water Temperature Cut-Out Setting
 For all open loop systems the 30°F (-1.1°C) LT1 setting (factory setting-water) should be used to avoid freeze damage to the unit. See Low temperature protection selection for closed loop systems with anitfreeze.

Water Quality Requirements

Table 3: Water Quality Requirements

Clean water is essential to the performance and life span of water source heat pumps. Contaminants, chemicals, and minerals all have the potential to cause damage to the water heat exchanger if not treated properly. All closed water loop systems should undergo water quality testing and be maintained to the water quality requirements listed in this table.

Table 3: Water Quality Requirements

| WATER QUALITY REQUIREMENTS | | | | | | | |
|--|--------------------------------------|----------------------------------|--------------------------------|---------------------------|---|--------------------------------|------------------------|
| For Closed-Loop and Open-Loop Systems | | | | | | | |
| | Description | Symbol | Units | Heat Exchanger Type | | | |
| | | | | Closed Loop Recirculating | Open Loop, Tower, Ground Source Well | | |
| | | | | | All Heat Exchanger Types | COAXIAL HX Copper Tube in Tube | COAXIAL HX Cupronickel |
| Scaling Potential | pH - Chilled Water <85°F | | | 7.0 to 9.0 | 7.0 to 9.0 | 7.0 to 9.0 | 7.0 to 9.0 |
| | pH - Heated Water >85°F | | | 8.0 to 10.0 | 8.0 to 10.0 | 8.0 to 10.0 | 8.0 to 10.0 |
| | Alkalinity | (HCO ₃) | ppm - CaCO ₃ equiv. | 50 to 500 | 50 to 500 | 50 to 500 | 50 to 500 |
| | Calcium | (Ca) | ppm | <100 | <100 | <100 | <100 |
| | Magnesium | (Mg) | ppm | <100 | <100 | <100 | <100 |
| | Total Hardness | (CaCO ₃) | ppm - CaCO ₃ equiv. | 30 to 150 | 150 to 450 | 150 to 450 | 150 to 450 |
| | Langelier Saturation Index | LSI | | -0.5 to +0.5 | -0.5 to +0.5 | -0.5 to +0.5 | -0.5 to +0.5 |
| Ryznar Stability Index | RSI | | 6.5 to 8.0 | 6.5 to 8.0 | 6.5 to 8.0 | 6.5 to 8.0 | |
| Corrosion Prevention | Total Dissolved Solids | (TDS) | ppm - CaCO ₃ equiv. | <1000 | <1000 | <1000 | <1500 |
| | Sulfate | (SO ₄ ²⁻) | ppm | <200 | <200 | <200 | <200 |
| | Nitrate | (NO ₃) | ppm | <100 | <100 | <100 | <100 |
| | Chlorine (free) | (Cl) | ppm | <0.5 | <0.5 | <0.5 | <0.5 |
| | Chloride (water < 80°F) | (Cl ⁻) | ppm | <20 | <20 | <150 | <150 |
| | Chloride (water > 120°F) | | ppm | <20 | <20 | <125 | <125 |
| | Hydrogen Sulfide ^a | (H ₂ S) | ppb | <0.5 | <0.5 | <0.5 | <0.5 |
| | Carbon Dioxide | (CO ₂) | ppm | 0 | <50 | 10 to 50 | 10 to 50 |
| | Iron Oxide | (Fe) | ppm | <1.0 | <1.0 | <1.0 | <0.2 |
| | Manganese | (Mn) | ppm | <0.4 | <0.4 | <0.4 | <0.4 |
| | Ammonia | (NH ₃) | ppm | <0.05 | <0.1 | <0.1 | <0.1 |
| Chloramine | (NH ₂ CL) | ppm | 0 | 0 | 0 | 0 | |
| Fouling & Biological | Iron Bacteria | | cells/mL | 0 | 0 | 0 | 0 |
| | Slime Forming Bacteria | | cells/mL | 0 | 0 | 0 | 0 |
| | Sulfate reducing bacteria | | cells/mL | 0 | 0 | 0 | 0 |
| | Suspended Solids ^b | (TSS) | ppm | <10 | <10 | <10 | <10 |
| Electrolysis All HX types | Earth Ground Resistance ^x | | Ohms | 0 | Consult NEC & local electrical codes for grounding requirements | | |
| | Electrolysis Voltage ^d | | mV | <300 | Measure voltage internal water loop to HP ground | | |
| | Leakage Current ^d | | mA | <15 | Measure current in water loop pipe | | |
| Building Primary Electrical Ground to unit, must meet local diameter and penetration length requirements Do not connect heat pump to steel pipe unless dissimilar materials are separated by using Di-electric unions. Galvanic corrosion of heat pump water pipe will occur. | | | | | | | |

Water Quality Requirements, Cont'd.

1. The Heat Controller Water Quality Table provides water quality requirements for coaxial & brazed plate heat exchangers.
2. The water must be evaluated by an independent testing facility comparing site samples against this table. When water properties are outside of these parameters, the water must either be treated by a professional water treatment specialist to bring the water quality within the boundaries of this specification, or an external secondary heat exchanger must be used to isolate the heat pump water system from the unsuitable water. Failure to do so will void the warranty of the heat pump system and will limit liability for damage caused by leaks or system failure.
3. Regular sampling, testing and treatment of the water is necessary to assure that the water quality remains within acceptable levels thereby allowing the heat pump to operate at optimum levels.
4. If closed-loop systems are turned off for extended periods, water samples must be tested prior to operating the system.
5. For optimal performance, it is recommended that the closed-loop piping systems are initially filled with de-ionized water.
6. Well water with chemistry outside of these boundaries, and salt water or brackish water requires an external secondary heat exchanger. Surface/Pond water should not be used.
7. If water temperature is expected to fall below 40°F, antifreeze is required. Refer to the heat pump IOM for the correct solution ratios to prevent freezing.
 - α Hydrogen Sulfide has an odor of rotten eggs. If one detects this smell, a test for H₂S must be performed. If H₂S is detected above the limit indicated, remediation is necessary (Consult with your Water Testing/Treatment Professional) or a secondary heat exchanger is required using appropriate materials as recommended by the heat exchanger supplier.
 - β Suspended solids and particulates must be filtered to prevent fouling and failure of heat exchangers. Strainers or particulate filters must be installed to provide a maximum particle size of 600 micron (0.60 mm, 0.023 in.) using a 20 to 30 mesh screen size. When a loop is installed in areas with fine material such as sand or clay, further filtration is required to a maximum of 100 micron. Refer to the Strainer / Filter Sizing Chart to capture the particle sizes encountered on the site.
 - χ An electrical grounding system using a dedicated ground rod meeting NEC and Local Electrical codes must be installed. Building Ground must not be connected the WSHP piping system or other plumbing pipes.
 - δ Refer to IOM for instructions on measuring resistance and leakage currents within water loops.

Do not use PVC pipe for water loop (compressor POE oil and glycols damage PVC) use of HDPE pipe is recommended.

| Strainer / Filter Sizing | | | |
|--------------------------|---------------|-------|--------|
| Mesh Size | Particle Size | | |
| | Microns | MM | Inch |
| 20 | 840 | 0.840 | 0.0340 |
| 30 | 533 | 0.533 | 0.0210 |
| 60 | 250 | 0.250 | 0.0100 |
| 100 | 149 | 0.149 | 0.0060 |
| 150 | 100 | 0.100 | 0.0040 |
| 200 | 74 | 0.074 | 0.0029 |

ppm = parts per million
ppb = parts per billion

Electrical Data



WARNING!

WARNING! To avoid possible injury or death due to electrical shock, open the power supply disconnect switch and secure it in an open position during installation.



CAUTION!

CAUTION! Use only copper conductors for field installed electrical wiring. Unit terminals are not designed to accept other types of conductors.

Table 4A: HKV Electrical Data Standard

| Model | Voltage Code | Voltage | Min/Max Voltage | Blower Option | Compressor | | | Fan Motor FLA | Total Unit FLA | Min Circuit Amp | Max Fuse/HACR |
|--------|--------------|----------|-----------------|---------------|------------|------|-------|---------------|----------------|-----------------|---------------|
| | | | | | QTY | RLA | LRA | | | | |
| HKV084 | H | 208-3-60 | 197/254 | A, B, C | 1 | 23.2 | 164.0 | 4.0 | 27.2 | 33.0 | 50 |
| | H | 208-3-60 | 197/254 | D, E | 1 | 23.2 | 164.0 | 5.0 | 28.2 | 34.0 | 50 |
| | F | 460-3-60 | 414/506 | A, B, C | 1 | 11.2 | 75.0 | 2.0 | 13.2 | 16.0 | 25 |
| | F | 460-3-60 | 414/506 | D, E | 1 | 11.2 | 75.0 | 2.4 | 13.6 | 16.4 | 25 |
| | N | 575-3-60 | 518/633 | A, B, C | 1 | 7.9 | 54.0 | 1.4 | 9.3 | 11.3 | 15 |
| | N | 575-3-60 | 518/633 | D, E | 1 | 7.9 | 54.0 | 1.9 | 9.8 | 11.8 | 15 |
| HKV096 | H | 208-3-60 | 197/254 | A, B, C | 1 | 25.0 | 164.0 | 5.0 | 30.0 | 36.3 | 60 |
| | H | 208-3-60 | 197/254 | D, E | 1 | 25.0 | 164.0 | 6.2 | 31.2 | 37.5 | 60 |
| | F | 460-3-60 | 414/506 | A, B, C | 1 | 12.2 | 100.0 | 2.4 | 14.6 | 17.6 | 25 |
| | F | 460-3-60 | 414/506 | D, E | 1 | 12.2 | 100.0 | 3.1 | 15.3 | 18.4 | 30 |
| | N | 575-3-60 | 518/633 | A, B, C | 1 | 9.0 | 78.0 | 1.9 | 10.9 | 13.1 | 20 |
| | N | 575-3-60 | 518/633 | D, E | 1 | 9.0 | 78.0 | 2.3 | 11.3 | 13.6 | 20 |
| HKV120 | H | 208-3-60 | 197/254 | A, B, C | 1 | 30.1 | 225.0 | 6.2 | 36.3 | 43.8 | 70 |
| | H | 208-3-60 | 197/254 | D, E | 1 | 30.1 | 225.0 | 9.2 | 39.3 | 46.8 | 70 |
| | F | 460-3-60 | 414/506 | A, B, C | 1 | 16.7 | 114.0 | 3.1 | 19.8 | 24.0 | 40 |
| | F | 460-3-60 | 414/506 | D, E | 1 | 16.7 | 114.0 | 4.3 | 21.0 | 25.2 | 40 |
| | N | 575-3-60 | 518/633 | A, B, C | 1 | 12.2 | 80.0 | 2.3 | 14.5 | 17.5 | 25 |
| | N | 575-3-60 | 518/633 | D, E | 1 | 12.2 | 80.0 | 3.4 | 15.6 | 18.6 | 30 |
| HKV150 | H | 208-3-60 | 197/254 | A, B, C | 1 | 48.1 | 245.0 | 9.2 | 57.3 | 69.3 | 110 |
| | H | 208-3-60 | 197/254 | D, E | 1 | 48.1 | 245.0 | 14.1 | 62.2 | 74.2 | 110 |
| | F | 460-3-60 | 414/506 | A, B, C | 1 | 18.6 | 125.0 | 4.3 | 22.9 | 27.6 | 45 |
| | F | 460-3-60 | 414/506 | D, E | 1 | 18.6 | 125.0 | 7.0 | 25.6 | 30.3 | 45 |
| | N | 575-3-60 | 518/633 | A, B, C | 1 | 14.7 | 100.0 | 3.4 | 18.1 | 21.8 | 35 |
| | N | 575-3-60 | 518/633 | D, E | 1 | 14.7 | 100.0 | 5.2 | 19.9 | 23.6 | 35 |
| HKV168 | H | 208-3-60 | 197/254 | A, B, C | 2 | 23.2 | 164.0 | 6.2 | 52.6 | 58.4 | 80 |
| | H | 208-3-60 | 197/254 | D, E | 2 | 23.2 | 164.0 | 9.2 | 55.6 | 61.4 | 80 |
| | F | 460-3-60 | 414/506 | A, B, C | 2 | 11.2 | 75.0 | 3.1 | 25.5 | 28.3 | 35 |
| | F | 460-3-60 | 414/506 | D, E | 2 | 11.2 | 75.0 | 4.3 | 26.7 | 29.5 | 40 |
| | N | 575-3-60 | 518/633 | A, B, C | 2 | 7.9 | 54.0 | 2.3 | 18.1 | 20.1 | 25 |
| | N | 575-3-60 | 518/633 | D, E | 2 | 7.9 | 54.0 | 3.4 | 19.2 | 21.2 | 25 |
| HKV192 | H | 208-3-60 | 197/254 | A, B, C | 2 | 25.0 | 164.0 | 9.2 | 59.2 | 65.4 | 90 |
| | H | 208-3-60 | 197/254 | D, E | 2 | 25.0 | 164.0 | 14.1 | 64.1 | 70.3 | 90 |
| | F | 460-3-60 | 414/506 | A, B, C | 2 | 12.2 | 100.0 | 4.3 | 28.7 | 31.8 | 40 |
| | F | 460-3-60 | 414/506 | D, E | 2 | 12.2 | 100.0 | 7.0 | 31.4 | 34.5 | 45 |
| | N | 575-3-60 | 518/633 | A, B, C | 2 | 9.0 | 78.0 | 3.4 | 21.4 | 23.6 | 30 |
| | N | 575-3-60 | 518/633 | D, E | 2 | 9.0 | 78.0 | 5.2 | 23.2 | 25.5 | 30 |
| HKV240 | H | 208-3-60 | 197/254 | A, B, C | 2 | 30.1 | 225.0 | 14.1 | 74.3 | 81.8 | 110 |
| | H | 208-3-60 | 197/254 | E | 2 | 30.1 | 225.0 | 21.7 | 81.9 | 89.4 | 110 |
| | F | 460-3-60 | 414/506 | A, B, C | 2 | 16.7 | 114.0 | 7.0 | 40.4 | 44.6 | 60 |
| | F | 460-3-60 | 414/506 | E | 2 | 16.7 | 114.0 | 10.0 | 43.4 | 47.6 | 60 |
| | N | 575-3-60 | 518/633 | A, B, C | 2 | 12.2 | 80.0 | 5.2 | 29.6 | 32.6 | 40 |
| | N | 575-3-60 | 518/633 | E | 2 | 12.2 | 80.0 | 7.7 | 32.1 | 35.1 | 45 |
| HKV300 | H | 208-3-60 | 197/254 | A, B, C | 2 | 48.1 | 245.0 | 14.1 | 110.3 | 122.3 | 150 |
| | H | 208-3-60 | 197/254 | D, E | 2 | 48.1 | 245.0 | 21.7 | 117.9 | 129.9 | 175 |
| | F | 460-3-60 | 414/506 | A, B, C | 2 | 18.6 | 125.0 | 7.0 | 44.2 | 48.9 | 60 |
| | F | 460-3-60 | 414/506 | D, E | 2 | 18.6 | 125.0 | 10.0 | 47.2 | 51.9 | 70 |
| | N | 575-3-60 | 518/633 | A, B, C | 2 | 14.7 | 100.0 | 5.2 | 34.6 | 38.3 | 50 |
| | N | 575-3-60 | 518/633 | D, E | 2 | 14.7 | 100.0 | 7.7 | 37.1 | 40.8 | 50 |

HACR circuit breaker in USA only
All fuses Class RK-5

Electrical Data, Cont'd.

Table 4B: HKV Electrical Data Dual Point

| Model | Voltage Code | Voltage | Min/Max Voltage | Blower Option | Compressor | | | | | | Emergency Power Supply | | |
|--------|--------------|----------|-----------------|---------------|------------|-------|-------|----------------|----------|--------------------|------------------------|-----------------|---------------|
| | | | | | QTY | RLA | LRA | Total Comp FLA | Comp MCA | Comp Max Fuse/HACR | Total Unit FLA | Min Circuit Amp | Max Fuse/HACR |
| HKV084 | H | 208-3-60 | 197/254 | A, B, C | 1 | 23.2 | 164.0 | 23.2 | 29.0 | 50 | 4.0 | 5.0 | 15 |
| | H | 208-3-60 | 197/254 | D, E | 1 | 23.2 | 164.0 | 23.2 | 29.0 | 50 | 5.0 | 6.3 | 15 |
| | F | 460-3-60 | 414/506 | A, B, C | 1 | 11.2 | 75.0 | 11.2 | 38.0 | 25 | 2.0 | 2.5 | 15 |
| | F | 460-3-60 | 414/506 | D, E | 1 | 11.2 | 75.0 | 11.2 | 38.0 | 25 | 2.4 | 3.0 | 15 |
| | N | 575-3-60 | 518/633 | A, B, C | 1 | 7.9 | 54.0 | 7.9 | 9.9 | 15 | 1.4 | 1.8 | 15 |
| N | 575-3-60 | 518/633 | D, E | 1 | 7.9 | 54.0 | 7.9 | 9.9 | 15 | 1.9 | 2.4 | 15 | |
| HKV096 | H | 208-3-60 | 197/254 | A, B, C | 1 | 25.0 | 164.0 | 25.0 | 31.3 | 50 | 5.0 | 6.3 | 15 |
| | H | 208-3-60 | 197/254 | D, E | 1 | 25.0 | 164.0 | 25.0 | 31.3 | 50 | 6.2 | 7.8 | 15 |
| | F | 460-3-60 | 414/506 | A, B, C | 1 | 12.2 | 100.0 | 12.2 | 15.3 | 25 | 2.4 | 3.0 | 15 |
| | F | 460-3-60 | 414/506 | D, E | 1 | 12.2 | 100.0 | 12.2 | 15.3 | 25 | 3.1 | 3.9 | 15 |
| | N | 575-3-60 | 518/633 | A, B, C | 1 | 9.0 | 78.0 | 9.0 | 11.3 | 20 | 1.9 | 2.4 | 15 |
| N | 575-3-60 | 518/633 | D, E | 1 | 9.0 | 78.0 | 9.0 | 11.3 | 20 | 2.3 | 2.9 | 15 | |
| HKV120 | H | 208-3-60 | 197/254 | A, B, C | 1 | 30.1 | 225.0 | 30.1 | 37.6 | 60 | 6.2 | 7.8 | 15 |
| | H | 208-3-60 | 197/254 | D, E | 1 | 30.1 | 225.0 | 30.1 | 37.6 | 60 | 9.2 | 11.5 | 20 |
| | F | 460-3-60 | 414/506 | A, B, C | 1 | 16.7 | 114.0 | 16.7 | 20.9 | 35 | 3.1 | 3.9 | 15 |
| | F | 460-3-60 | 414/506 | D, E | 1 | 16.7 | 114.0 | 16.7 | 20.9 | 35 | 4.3 | 5.4 | 15 |
| | N | 575-3-60 | 518/633 | A, B, C | 1 | 12.2 | 80.0 | 12.2 | 15.3 | 25 | 2.3 | 2.9 | 15 |
| N | 575-3-60 | 518/633 | D, E | 1 | 12.2 | 80.0 | 12.2 | 15.3 | 25 | 3.4 | 4.3 | 15 | |
| HKV150 | H | 208-3-60 | 197/254 | A, B, C | 1 | 48.1 | 245.0 | 48.1 | 60.1 | 100 | 9.2 | 11.5 | 20 |
| | H | 208-3-60 | 197/254 | D, E | 1 | 48.1 | 245.0 | 48.1 | 60.1 | 100 | 14.1 | 17.6 | 30 |
| | F | 460-3-60 | 414/506 | A, B, C | 1 | 18.6 | 125.0 | 18.6 | 23.3 | 40 | 4.3 | 5.4 | 15 |
| | F | 460-3-60 | 414/506 | D, E | 1 | 18.6 | 125.0 | 18.6 | 23.3 | 40 | 7.0 | 8.8 | 15 |
| | N | 575-3-60 | 518/633 | A, B, C | 1 | 14.7 | 100.0 | 14.7 | 18.4 | 30 | 3.4 | 4.3 | 15 |
| N | 575-3-60 | 518/633 | D, E | 1 | 14.7 | 100.0 | 14.7 | 18.4 | 30 | 5.2 | 6.5 | 15 | |
| HKV168 | H | 208-3-60 | 197/254 | A, B, C | 2 | 23.2 | 164.0 | 46.4 | 52.2 | 70 | 6.2 | 7.8 | 15 |
| | H | 208-3-60 | 197/254 | D, E | 2 | 23.2 | 164.0 | 46.4 | 52.2 | 70 | 9.2 | 11.5 | 20 |
| | F | 460-3-60 | 414/506 | A, B, C | 2 | 11.2 | 75.0 | 22.4 | 25.2 | 35 | 3.1 | 3.9 | 15 |
| | F | 460-3-60 | 414/506 | D, E | 2 | 11.2 | 75.0 | 22.4 | 25.2 | 35 | 4.3 | 5.4 | 15 |
| | N | 575-3-60 | 518/633 | A, B, C | 2 | 7.9 | 54.0 | 15.8 | 17.8 | 25 | 2.3 | 2.9 | 15 |
| N | 575-3-60 | 518/633 | D, E | 2 | 7.9 | 54.0 | 15.8 | 17.8 | 25 | 3.4 | 4.3 | 15 | |
| HKV192 | H | 208-3-60 | 197/254 | A, B, C | 2 | 25.0 | 164.0 | 50.0 | 56.3 | 80 | 9.2 | 11.5 | 20 |
| | H | 208-3-60 | 197/254 | D, E | 2 | 25.0 | 164.0 | 50.0 | 56.3 | 80 | 14.1 | 17.6 | 30 |
| | F | 460-3-60 | 414/506 | A, B, C | 2 | 12.2 | 100.0 | 24.4 | 27.4 | 35 | 4.3 | 5.4 | 15 |
| | F | 460-3-60 | 414/506 | D, E | 2 | 12.2 | 100.0 | 24.4 | 27.4 | 35 | 7.0 | 8.8 | 15 |
| | N | 575-3-60 | 518/633 | A, B, C | 2 | 9.0 | 78.0 | 18.0 | 20.3 | 25 | 3.4 | 4.3 | 15 |
| N | 575-3-60 | 518/633 | D, E | 2 | 9.0 | 78.0 | 18.0 | 20.3 | 25 | 5.2 | 6.5 | 15 | |
| HKV240 | H | 208-3-60 | 197/254 | A, B, C | 2 | 30.1 | 225.0 | 60.2 | 67.7 | 90 | 14.1 | 17.6 | 30 |
| | H | 208-3-60 | 197/254 | E | 2 | 30.1 | 225.0 | 60.2 | 67.7 | 90 | 21.7 | 27.1 | 45 |
| | F | 460-3-60 | 414/506 | A, B, C | 2 | 16.7 | 114.0 | 33.4 | 37.6 | 50 | 7.0 | 8.8 | 15 |
| | F | 460-3-60 | 414/506 | E | 2 | 16.7 | 114.0 | 33.4 | 37.6 | 50 | 10.0 | 12.5 | 20 |
| | N | 575-3-60 | 518/633 | A, B, C | 2 | 12.2 | 80.0 | 24.4 | 27.4 | 35 | 5.2 | 6.5 | 15 |
| N | 575-3-60 | 518/633 | E | 2 | 12.2 | 80.0 | 24.4 | 27.4 | 35 | 7.7 | 9.6 | 15 | |
| HKV300 | H | 208-3-60 | 197/254 | A, B, C | 2 | 48.1 | 245.0 | 96.2 | 108.2 | 150 | 14.1 | 17.6 | 30 |
| | H | 208-3-60 | 197/254 | D, E | 2 | 48.1 | 245.0 | 96.2 | 108.2 | 150 | 21.7 | 27.1 | 45 |
| | F | 460-3-60 | 414/506 | A, B, C | 2 | 18.6 | 125.0 | 37.2 | 41.9 | 60 | 7.0 | 8.8 | 15 |
| | F | 460-3-60 | 414/506 | D, E | 2 | 18.6 | 125.0 | 37.2 | 41.9 | 60 | 10.0 | 12.5 | 20 |
| | N | 575-3-60 | 518/633 | A, B, C | 2 | 14.7 | 100.0 | 29.4 | 33.1 | 45 | 5.2 | 6.5 | 15 |
| N | 575-3-60 | 518/633 | D, E | 2 | 14.7 | 100.0 | 29.4 | 33.1 | 45 | 7.7 | 9.6 | 15 | |

HACR circuit breaker in USA only
All fuses Class RK-5

Electrical Data, Cont'd.

Table 4C: HKV Electrical Data Standard with Internal Pump

| Model | Voltage Code | Voltage | Min/Max Voltage | Blower Option | Compressor | | | Fan Motor FLA | Pump | | Total Unit FLA | Min Circuit Amp | Max Fuse / HACR |
|--------|--------------|----------|-----------------|---------------|------------|------|-------|---------------|------|------|----------------|-----------------|-----------------|
| | | | | | QTY | RLA | LRA | | QTY | FLA | | | |
| HKV084 | H | 208-3-60 | 197/254 | A, B, C | 1 | 23.2 | 164.0 | 4.0 | 1 | 1.10 | 28.3 | 34.1 | 50 |
| | H | 208-3-60 | 197/254 | D, E | 1 | 23.2 | 164.0 | 5.0 | 1 | 1.10 | 29.3 | 35.1 | 50 |
| | F | 460-3-60 | 414/506 | A, B, C | 1 | 11.2 | 75.0 | 2.0 | 1 | 0.55 | 13.8 | 16.5 | 25 |
| | F | 460-3-60 | 414/506 | D, E | 1 | 11.2 | 75.0 | 2.4 | 1 | 0.55 | 14.1 | 17.0 | 25 |
| | N | 575-3-60 | 518/633 | A, B, C | 1 | 7.9 | 54.0 | 1.4 | 1 | 0.44 | 9.7 | 11.7 | 15 |
| | N | 575-3-60 | 518/633 | D, E | 1 | 7.9 | 54.0 | 1.9 | 1 | 0.44 | 10.2 | 12.2 | 20 |
| HKV096 | H | 208-3-60 | 197/254 | A, B, C | 1 | 25.0 | 164.0 | 5.0 | 1 | 1.96 | 32.0 | 38.2 | 60 |
| | H | 208-3-60 | 197/254 | D, E | 1 | 25.0 | 164.0 | 6.2 | 1 | 1.96 | 33.2 | 39.4 | 60 |
| | F | 460-3-60 | 414/506 | A, B, C | 1 | 12.2 | 100.0 | 2.4 | 1 | 0.98 | 15.6 | 18.6 | 30 |
| | F | 460-3-60 | 414/506 | D, E | 1 | 12.2 | 100.0 | 3.1 | 1 | 0.98 | 16.3 | 19.3 | 30 |
| | N | 575-3-60 | 518/633 | A, B, C | 1 | 9.0 | 78.0 | 1.9 | 1 | 0.78 | 11.7 | 13.9 | 20 |
| | N | 575-3-60 | 518/633 | D, E | 1 | 9.0 | 78.0 | 2.3 | 1 | 0.78 | 12.1 | 14.3 | 20 |
| HKV120 | H | 208-3-60 | 197/254 | A, B, C | 1 | 30.1 | 225.0 | 6.2 | 1 | 1.96 | 38.3 | 45.8 | 70 |
| | H | 208-3-60 | 197/254 | D, E | 1 | 30.1 | 225.0 | 9.2 | 1 | 1.96 | 41.3 | 48.8 | 70 |
| | F | 460-3-60 | 414/506 | A, B, C | 1 | 16.7 | 114.0 | 3.1 | 1 | 0.98 | 20.8 | 25.0 | 40 |
| | F | 460-3-60 | 414/506 | D, E | 1 | 16.7 | 114.0 | 4.3 | 1 | 0.98 | 22.0 | 26.2 | 40 |
| | N | 575-3-60 | 518/633 | A, B, C | 1 | 12.2 | 80.0 | 2.3 | 1 | 0.78 | 15.3 | 18.3 | 30 |
| | N | 575-3-60 | 518/633 | E | 1 | 12.2 | 80.0 | 3.4 | 1 | 0.78 | 16.4 | 19.4 | 30 |
| HKV150 | H | 208-3-60 | 197/254 | A, B, C | 1 | 48.1 | 245.0 | 9.2 | 1 | 1.96 | 59.3 | 71.3 | 110 |
| | H | 208-3-60 | 197/254 | D, E | 1 | 48.1 | 245.0 | 14.1 | 1 | 1.96 | 64.2 | 76.2 | 110 |
| | F | 460-3-60 | 414/506 | A, B, C | 1 | 18.6 | 125.0 | 4.3 | 1 | 0.98 | 23.9 | 28.5 | 45 |
| | F | 460-3-60 | 414/506 | D, E | 1 | 18.6 | 125.0 | 7.0 | 1 | 0.98 | 26.6 | 31.2 | 45 |
| | N | 575-3-60 | 518/633 | A, B, C | 1 | 14.7 | 100.0 | 3.4 | 1 | 0.78 | 18.9 | 22.6 | 35 |
| | N | 575-3-60 | 518/633 | D, E | 1 | 14.7 | 100.0 | 5.2 | 1 | 0.78 | 20.7 | 24.4 | 35 |
| HKV168 | H | 208-3-60 | 197/254 | A, B, C | 2 | 23.2 | 164.0 | 6.2 | 2 | 1.10 | 54.8 | 60.6 | 80 |
| | H | 208-3-60 | 197/254 | D, E | 2 | 23.2 | 164.0 | 9.2 | 2 | 1.10 | 57.8 | 63.6 | 80 |
| | F | 460-3-60 | 414/506 | A, B, C | 2 | 11.2 | 75.0 | 3.1 | 2 | 0.55 | 26.6 | 29.4 | 40 |
| | F | 460-3-60 | 414/506 | D, E | 2 | 11.2 | 75.0 | 4.3 | 2 | 0.55 | 27.8 | 30.6 | 40 |
| | N | 575-3-60 | 518/633 | A, B, C | 2 | 7.9 | 54.0 | 2.3 | 2 | 0.44 | 19.0 | 21.0 | 25 |
| | N | 575-3-60 | 518/633 | D, E | 2 | 7.9 | 54.0 | 3.4 | 2 | 0.44 | 20.1 | 22.1 | 25 |
| HKV192 | H | 208-3-60 | 197/254 | A, B, C | 2 | 25.0 | 164.0 | 9.2 | 2 | 1.96 | 63.1 | 69.4 | 90 |
| | H | 208-3-60 | 197/254 | D, E | 2 | 25.0 | 164.0 | 14.1 | 2 | 1.96 | 68.0 | 74.3 | 90 |
| | F | 460-3-60 | 414/506 | A, B, C | 2 | 12.2 | 100.0 | 4.3 | 2 | 0.98 | 30.7 | 33.7 | 45 |
| | F | 460-3-60 | 414/506 | D, E | 2 | 12.2 | 100.0 | 7.0 | 2 | 0.98 | 33.4 | 36.4 | 45 |
| | N | 575-3-60 | 518/633 | A, B, C | 2 | 9.0 | 78.0 | 3.4 | 2 | 0.78 | 23.0 | 25.2 | 30 |
| | N | 575-3-60 | 518/633 | D, E | 2 | 9.0 | 78.0 | 5.2 | 2 | 0.78 | 24.8 | 27.0 | 35 |
| HKV240 | H | 208-3-60 | 197/254 | A, B, C | 2 | 30.1 | 225.0 | 14.1 | 2 | 1.96 | 78.2 | 85.7 | 110 |
| | H | 208-3-60 | 197/254 | E | 2 | 30.1 | 225.0 | 21.7 | 2 | 1.96 | 85.8 | 93.3 | 110 |
| | F | 460-3-60 | 414/506 | A, B, C | 2 | 16.7 | 114.0 | 7.0 | 2 | 0.98 | 42.4 | 46.5 | 60 |
| | F | 460-3-60 | 414/506 | E | 2 | 16.7 | 114.0 | 10.0 | 2 | 0.98 | 45.4 | 49.5 | 60 |
| | N | 575-3-60 | 518/633 | A, B, C | 2 | 12.2 | 80.0 | 5.2 | 2 | 0.78 | 31.2 | 34.2 | 45 |
| | N | 575-3-60 | 518/633 | E | 2 | 12.2 | 80.0 | 7.7 | 2 | 0.78 | 33.7 | 36.7 | 45 |
| HKV300 | H | 208-3-60 | 197/254 | A, B, C | 2 | 48.1 | 245.0 | 14.1 | 2 | 1.96 | 114.2 | 126.2 | 150 |
| | H | 208-3-60 | 197/254 | D, E | 2 | 48.1 | 245.0 | 21.7 | 2 | 1.96 | 121.8 | 133.8 | 175 |
| | F | 460-3-60 | 414/506 | A, B, C | 2 | 18.6 | 125.0 | 7.0 | 2 | 0.98 | 46.2 | 50.8 | 60 |
| | F | 460-3-60 | 414/506 | D, E | 2 | 18.6 | 125.0 | 10.0 | 2 | 0.98 | 49.2 | 53.8 | 70 |
| | N | 575-3-60 | 518/633 | A, B, C | 2 | 14.7 | 100.0 | 5.2 | 2 | 0.78 | 36.2 | 39.8 | 50 |
| | N | 575-3-60 | 518/633 | D, E | 2 | 14.7 | 100.0 | 7.7 | 2 | 0.78 | 38.7 | 42.3 | 50 |

HACR circuit breaker in USA only
All fuses Class RK-5

Electrical Data, Cont'd.

Table 4D: HKV Electrical Data Dual Point Power with Pump

| Model | Voltage Code | Voltage | Min/Max Voltage | Blower Option | Compressor | | | | | | | | Emergency Power Supply | | |
|--------|--------------|----------|-----------------|---------------|------------|------|-------|-----|----------|-----------|-------|---------------|------------------------|---------|-------------------|
| | | | | | QTY | RLA | LRA | QTY | Pump FLA | Total FLA | MCA | Max Fuse/HACR | Fan Motor FLA | Fan MCA | Fan Max Fuse/HACR |
| HKV084 | H | 208-3-60 | 197/254 | A, B, C | 1 | 23.2 | 164.0 | 1 | 1.10 | 24.3 | 30.1 | 50 | 4.0 | 5.0 | 15 |
| | H | 208-3-60 | 197/254 | D, E | 1 | 23.2 | 164.0 | 1 | 1.10 | 24.3 | 30.1 | 50 | 5.0 | 6.3 | 15 |
| | F | 460-3-60 | 414/506 | A, B, C | 1 | 11.2 | 75.0 | 1 | 0.55 | 11.8 | 14.6 | 25 | 2.0 | 2.5 | 15 |
| | F | 460-3-60 | 414/506 | D, E | 1 | 11.2 | 75.0 | 1 | 0.55 | 11.8 | 14.6 | 25 | 2.4 | 3.0 | 15 |
| | N | 575-3-60 | 518/633 | A, B, C | 1 | 7.9 | 54.0 | 1 | 0.44 | 8.3 | 10.3 | 15 | 1.4 | 1.8 | 15 |
| HKV096 | N | 575-3-60 | 518/633 | D, E | 1 | 7.9 | 54.0 | 1 | 0.44 | 8.3 | 10.3 | 15 | 1.9 | 2.4 | 15 |
| | H | 208-3-60 | 197/254 | A, B, C | 1 | 25.0 | 164.0 | 1 | 1.96 | 27.0 | 33.2 | 50 | 5.0 | 6.3 | 15 |
| | H | 208-3-60 | 197/254 | D, E | 1 | 25.0 | 164.0 | 1 | 1.96 | 27.0 | 33.2 | 50 | 6.2 | 7.8 | 15 |
| | F | 460-3-60 | 414/506 | A, B, C | 1 | 12.2 | 100.0 | 1 | 0.98 | 13.2 | 16.2 | 25 | 2.4 | 3.0 | 15 |
| | F | 460-3-60 | 414/506 | D, E | 1 | 12.2 | 100.0 | 1 | 0.98 | 13.2 | 16.2 | 25 | 3.1 | 3.9 | 15 |
| HKV120 | N | 575-3-60 | 518/633 | A, B, C | 1 | 9.0 | 78.0 | 1 | 0.78 | 9.8 | 12.0 | 20 | 1.9 | 2.4 | 15 |
| | N | 575-3-60 | 518/633 | D, E | 1 | 9.0 | 78.0 | 1 | 0.78 | 9.8 | 12.0 | 20 | 2.3 | 2.9 | 15 |
| | H | 208-3-60 | 197/254 | A, B, C | 1 | 30.1 | 225.0 | 1 | 1.96 | 32.1 | 39.6 | 60 | 6.2 | 7.8 | 15 |
| | H | 208-3-60 | 197/254 | D, E | 1 | 30.1 | 225.0 | 1 | 1.96 | 32.1 | 39.6 | 60 | 9.2 | 11.5 | 20 |
| | F | 460-3-60 | 414/506 | A, B, C | 1 | 16.7 | 114.0 | 1 | 0.98 | 17.7 | 21.9 | 35 | 3.1 | 3.9 | 15 |
| HKV150 | F | 460-3-60 | 414/506 | D, E | 1 | 16.7 | 114.0 | 1 | 0.98 | 17.7 | 21.9 | 65 | 4.3 | 5.4 | 15 |
| | N | 575-3-60 | 518/633 | A, B, C | 1 | 12.2 | 80.0 | 1 | 0.78 | 13.0 | 16.0 | 25 | 2.3 | 2.9 | 15 |
| | N | 575-3-60 | 518/633 | E | 1 | 12.2 | 80.0 | 1 | 0.78 | 13.0 | 16.0 | 25 | 3.4 | 4.3 | 15 |
| | H | 208-3-60 | 197/254 | A, B, C | 1 | 48.1 | 245.0 | 1 | 1.96 | 50.1 | 62.1 | 110 | 9.2 | 11.5 | 20 |
| | H | 208-3-60 | 197/254 | D, E | 1 | 48.1 | 245.0 | 1 | 1.96 | 50.1 | 62.1 | 110 | 14.1 | 17.6 | 30 |
| HKV168 | F | 460-3-60 | 414/506 | A, B, C | 1 | 18.6 | 125.0 | 1 | 0.98 | 19.6 | 24.2 | 40 | 4.3 | 5.4 | 15 |
| | F | 460-3-60 | 414/506 | D, E | 1 | 18.6 | 125.0 | 1 | 0.98 | 19.6 | 24.2 | 40 | 7.0 | 8.8 | 15 |
| | N | 575-3-60 | 518/633 | A, B, C | 1 | 14.7 | 100.0 | 1 | 0.78 | 15.5 | 19.2 | 30 | 3.4 | 4.3 | 15 |
| | N | 575-3-60 | 518/633 | D, E | 1 | 14.7 | 100.0 | 1 | 0.78 | 15.5 | 19.2 | 30 | 5.2 | 6.5 | 15 |
| | H | 208-3-60 | 197/254 | A, B, C | 2 | 23.2 | 164.0 | 2 | 1.10 | 48.6 | 54.4 | 70 | 6.2 | 7.8 | 15 |
| HKV192 | H | 208-3-60 | 197/254 | D, E | 2 | 23.2 | 164.0 | 2 | 1.10 | 48.6 | 54.4 | 70 | 9.2 | 11.5 | 20 |
| | F | 460-3-60 | 414/506 | A, B, C | 2 | 11.2 | 75.0 | 2 | 0.55 | 23.5 | 26.3 | 35 | 3.1 | 3.9 | 15 |
| | F | 460-3-60 | 414/506 | D, E | 2 | 11.2 | 75.0 | 2 | 0.55 | 23.5 | 26.3 | 35 | 4.3 | 5.4 | 15 |
| | N | 575-3-60 | 518/633 | A, B, C | 2 | 7.9 | 54.0 | 2 | 0.44 | 16.7 | 18.7 | 25 | 2.3 | 2.9 | 15 |
| | N | 575-3-60 | 518/633 | D, E | 2 | 7.9 | 54.0 | 2 | 0.44 | 16.7 | 18.7 | 25 | 3.4 | 4.3 | 15 |
| HKV240 | H | 208-3-60 | 197/254 | A, B, C | 2 | 25.0 | 164.0 | 2 | 1.96 | 53.9 | 60.2 | 80 | 9.2 | 11.5 | 20 |
| | H | 208-3-60 | 197/254 | D, E | 2 | 25.0 | 164.0 | 2 | 1.96 | 53.9 | 60.2 | 80 | 14.1 | 17.6 | 30 |
| | F | 460-3-60 | 414/506 | A, B, C | 2 | 12.2 | 100.0 | 2 | 0.98 | 26.4 | 29.4 | 40 | 4.3 | 5.4 | 15 |
| | F | 460-3-60 | 414/506 | D, E | 2 | 12.2 | 100.0 | 2 | 0.98 | 26.4 | 29.4 | 40 | 7.0 | 8.8 | 15 |
| | N | 575-3-60 | 518/633 | A, B, C | 2 | 9.0 | 78.0 | 2 | 0.78 | 19.6 | 21.8 | 30 | 3.4 | 4.3 | 15 |
| HKV300 | N | 575-3-60 | 518/633 | D, E | 2 | 9.0 | 78.0 | 2 | 0.78 | 19.6 | 21.8 | 30 | 5.2 | 6.5 | 15 |
| | H | 208-3-60 | 197/254 | A, B, C | 2 | 30.1 | 225.0 | 2 | 1.96 | 64.1 | 71.6 | 100 | 14.1 | 17.6 | 30 |
| | H | 208-3-60 | 197/254 | E | 2 | 30.1 | 225.0 | 2 | 1.96 | 64.1 | 71.6 | 100 | 21.7 | 27.1 | 45 |
| | F | 460-3-60 | 414/506 | A, B, C | 2 | 16.7 | 114.0 | 2 | 0.98 | 35.4 | 39.5 | 50 | 7.0 | 8.8 | 15 |
| | F | 460-3-60 | 414/506 | E | 2 | 16.7 | 114.0 | 2 | 0.98 | 35.4 | 39.5 | 50 | 10.0 | 12.5 | 20 |
| HKV300 | N | 575-3-60 | 518/633 | A, B, C | 2 | 12.2 | 80.0 | 2 | 0.78 | 26.0 | 29.0 | 40 | 5.2 | 6.5 | 15 |
| | N | 575-3-60 | 518/633 | E | 2 | 12.2 | 80.0 | 2 | 0.78 | 26.0 | 29.0 | 40 | 7.7 | 9.6 | 15 |
| | H | 208-3-60 | 197/254 | A, B, C | 2 | 48.1 | 245.0 | 2 | 1.96 | 100.1 | 112.1 | 150 | 14.1 | 17.6 | 30 |
| | H | 208-3-60 | 197/254 | D, E | 2 | 48.1 | 245.0 | 2 | 1.96 | 100.1 | 112.1 | 150 | 21.7 | 27.1 | 45 |
| | F | 460-3-60 | 414/506 | A, B, C | 2 | 18.6 | 125.0 | 2 | 0.98 | 39.2 | 43.8 | 60 | 7.0 | 8.8 | 15 |
| HKV300 | F | 460-3-60 | 414/506 | D, E | 2 | 18.6 | 125.0 | 2 | 0.98 | 39.2 | 43.8 | 60 | 10.0 | 12.5 | 20 |
| | N | 575-3-60 | 518/633 | A, B, C | 2 | 14.7 | 100.0 | 2 | 0.78 | 31.0 | 34.6 | 45 | 5.2 | 6.5 | 15 |
| | N | 575-3-60 | 518/633 | D, E | 2 | 14.7 | 100.0 | 2 | 0.78 | 31.0 | 34.6 | 45 | 7.7 | 9.6 | 15 |

HACR circuit breaker in USA only
All fuses Class RK-5

Electrical – Power Wiring

! WARNING! !

WARNING! To avoid possible injury or death due to electrical shock, open the power supply disconnect switch and secure it in an open position during installation.

! CAUTION! !

CAUTION! Use only copper conductors for field installed electrical wiring. Unit terminals are not designed to accept other types of conductors.

! WARNING! !

WARNING! Disconnect electrical power source to prevent injury or death from electrical shock.

General Line Voltage Wiring - Be sure the available power is the same voltage and phase as that shown on the unit serial plate. Line and low voltage wiring must be done in accordance with local codes or the National Electric Code, whichever is applicable.

HKV Power Connection - Line voltage connection is made by connecting the incoming line voltage wires to the power block as shown in Figure 6. Consult Table 4a and 4b for correct fuse size.

208 Volt Operation - All 208-230 Volt units are factory wired for 208 Volt. The transformers may be switched to 230V operation as illustrated on the wiring diagram by switching the Red (208V) and the Orange (230V) at the contactor terminal L2.

All field installed wiring, including electrical ground, must comply with the National Electrical Code as well as all applicable local codes.

Refer to the unit wiring diagrams for fuse sizes and a schematic of the field connections which must be made by the installing (or electrical) contractor.

Consult the unit wiring diagram located on the inside of the compressor access panel to ensure proper electrical hookup.

All final electrical connections must be made with a length of flexible conduit to minimize vibration and sound transmission to the building.

Thermostat Installation - The thermostat should be located on an interior wall in a larger room away from supply duct drafts. Do NOT locate the thermostat in areas subject to sunlight, drafts or on external walls. The wire access hole behind the thermostat may in certain cases need to be sealed to prevent erroneous temperature measurement. Position the thermostat backplate against the wall so that it appears level and so the thermostat wires protrude through the middle of the backplate. Mark the position of the backplate mounting holes and drill holes with a 3/16" bit. Install supplied anchors and secure plate to the wall. Thermostat wire must be 18 AWG wire. Wire the appropriate thermostat as shown in Figure 13 to the low voltage terminal strip in the CXM2/DXM2.5 Control as shown in Figure 7 using 18 AWG thermostat wire of minimum length.

Figure 8: Typical HKV Series Line Voltage Field Wiring

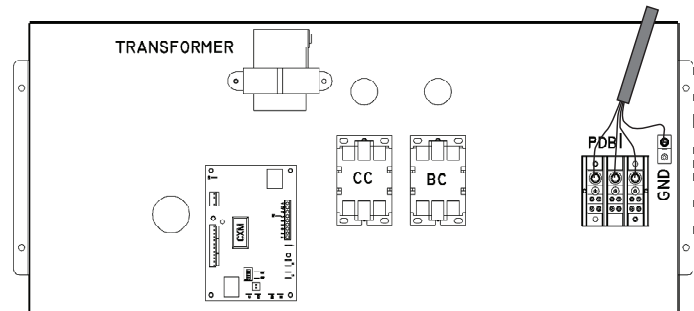

CONTROL BOX LAYOUT STANDARD

Figure 9: Low Voltage Field Wiring (CXM2 shown)

NOTE: For DXM2.5, Y2 wiring

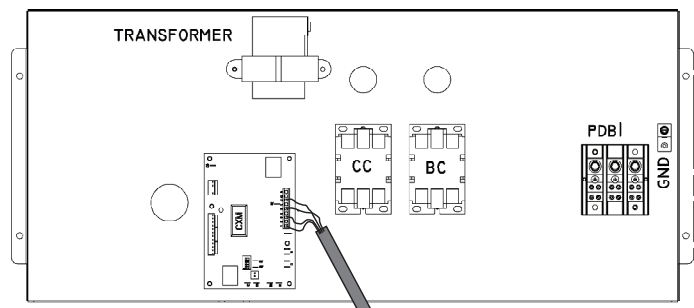

CONTROL BOX LAYOUT STANDARD

Electrical - Low Voltage

Low Water Temperature Cutout - LT1 - The CXM2/DXM2.5 control allows the field selection of source fluid low temperature cutout points. The factory setting of LT1 is set for water (30°F [-1.1°C]). In cold temperature applications jumper JW3 (LT1- antifreeze 10°F [-12.2°C]) should be clipped as shown in Figure 10 to change the setting to 10°F [-12.2°C], a more suitable temperature when using antifreezes. It should be noted that the extended range option should be specified to operate the HKV Series at entering water temperatures below 60°F [15°C].

Accessory Connections - A terminal paralleling the compressor contactor coil has been provided on the CXM2/DXM2.5 control of the HKV line. "A" has been provided to control accessory devices, such as water valves, electronic air cleaners, humidifiers, etc. Note: This terminal should be used only with 24 Volt signals and not line voltage signals. This signal operates with the compressor contactor. See Figure 11 or the wiring **Figure 11: Accessory Wiring**

Terminal Strip

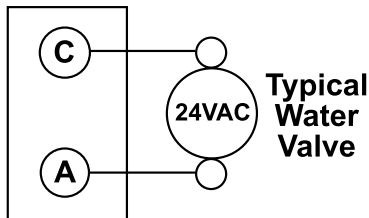

schematic for details.

Water Solenoid Valves - When using external solenoid valves on ground water installations, a slow closing valve may be desired. Figure 11 illustrates a typical slow closing water control valve wiring which will limit wasted water during a lockout condition. A slow closing valve may be required to prevent water hammer. When using an AVM -Taco Slow Closing valve on HKV Series equipment Figure 12 wiring should be utilized. The valve takes approximately 60 seconds to open (very little HKV water will flow before 45 seconds) and it activates the compressor only after the valve is completely opened (by closing its end switch). Only relay or triac based electronic thermostats should be used with the AVM valve. When wired as shown, the valve will operate properly with the following notations:

1. The valve will remain open during a unit lockout.
2. The valve will draw approximately 25-35 VA through the "Y" signal of the thermostat. Note: This can overheat the anticipators of electromechanical thermostats. Therefore only relay or triac based thermostats should be used.

Figure 12: Typical Well Water AVM Valve Wiring

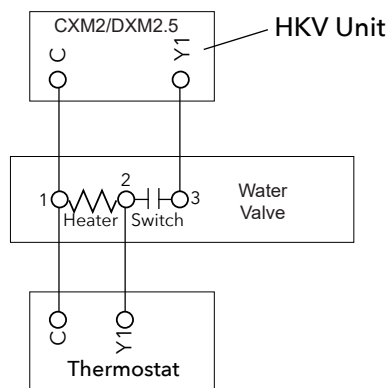

ELECTRICAL - THERMOSTAT

Typical Thermostat Selection and Wiring - Practically any multi-stage contact type thermostat will work with the ELV Series. Figure 13a and 13b show typical thermostat wiring. **Thermostats with Triac outputs are not compatible with CXM2 boards.**

Figure 13a: Typical Manual Changeover 2 heat/ 2 cool thermostat wiring

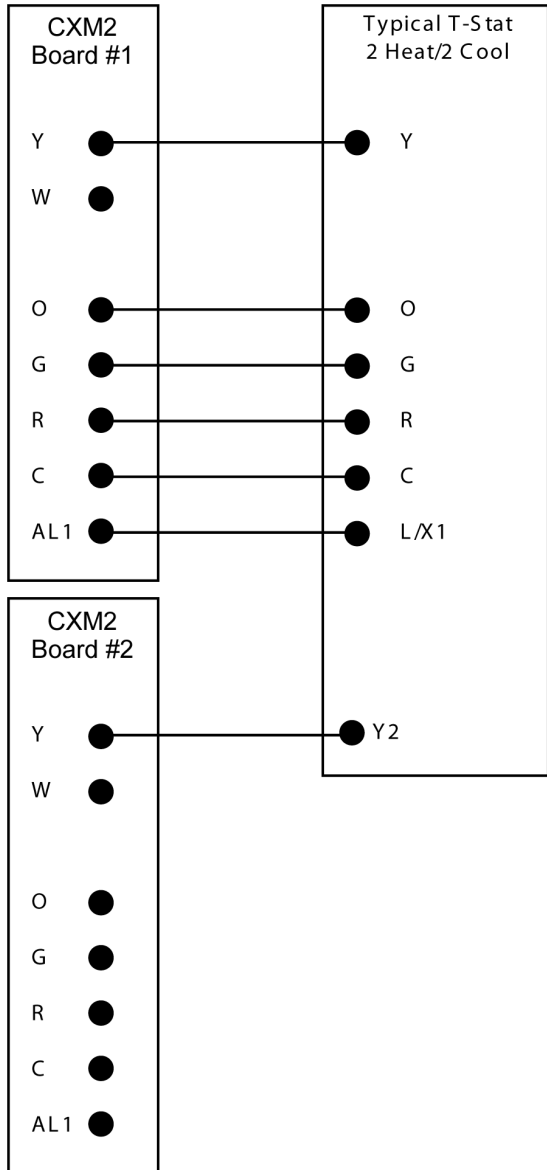
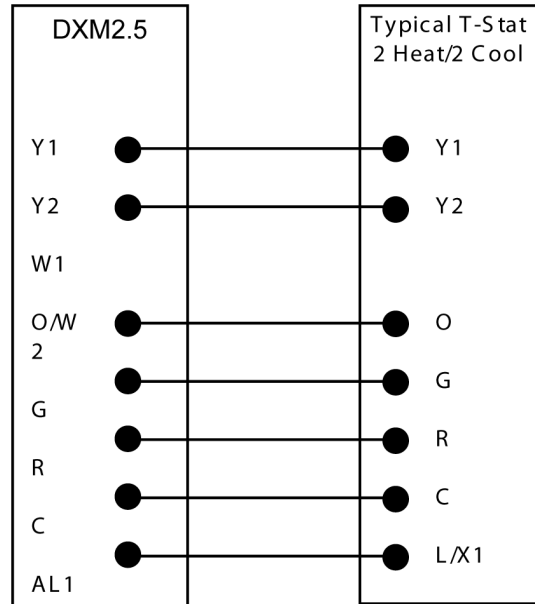

Figure 13b: Typical Manual Changeover 2 heat/ 2 cool thermostat wiring



NOTE: For units with two (2) DXM2.5 boards all thermostat connections will be made to the "Master" DXM2.5 board. **DO NOT** connect thermostat wiring to the "Slave" DXM2.5 board.

HKV Series Wiring Diagram Matrix

Diagrams can be located online at <https://files.hvac-wiringdiagrams.com/MARS/marswire.html> using the part numbers presented below.

| Unit Controller | Options | 208-230/60/3 | | 460/60/3 | | 575/60/3 | |
|--------------------------------------|---------------------|--------------|------------|------------|------------|------------|------------|
| | | 84-150 | 168-300 | 84-150 | 168-300 | 84-150 | 168-300 |
| CXM2 | None | 96B0113N42 | 96B0113N45 | 96B0113N42 | 96B0113N45 | 96B0113N42 | 96B0113N45 |
| DXM2.5 | None/ISP/MWV | 96B0113N52 | 96B0113N46 | 96B0113N52 | 96B0113N46 | 96B0113N52 | 96B0113N46 |
| Auxiliary WD for MPC Controls | | 96B0149N09 | | | | | |

Controls – CXM2 and DXM2.5



CXM2 Controls

For detailed controller information, see the CXM2 Application, Operation, and Maintenance (AOM) manual (part # 97B0137N01). To confirm the controller type of your particular unit, refer to digit 9 on the unit model number and the unit nomenclature diagram found on page 3 of this manual.



DXM2.5 Controls

For detailed controller information, see the DXM2.5 Application, Operation, and Maintenance (AOM) manual (part # 97B0142N01). To confirm the controller type of your particular unit, refer to digit 9 on the unit model number and the unit nomenclature diagram found on page 3 of this manual.

Blower Adjustment

CAUTION!

CAUTION! Always disconnect all power supply(s) to unit prior to making belt or sheave adjustments. Inadvertently starting of the motor can cause damage to the equipment and personal injury.

Airflow and External Static Pressure

Selection Adjustment

The HKV Series is available with standard, low, and high static options. These options will substitute a different blower drive sheave for each static range. In addition certain static ranges may require the optional large fan motor. Please specify static range and motor horsepower when ordering. See model nomenclature.

Sheave Adjustment

The HKV Series is supplied with variable sheave drive on the fan motor to adjust for differing airflows at various ESP conditions. Select an airflow requirement on the left side of the table, then move horizontally to right under the required ESP. Note the sheave turns open, rpm and horsepower for that condition. Fully closed the sheave will produce the highest static capability (higher rpm). To adjust sheave position: loosen belt tension and remove belt, loosen set screw on variable sheave (on fan motor) and open sheave to desired position. Retighten set screw and replace belt and set belt tension as below.

Belt Tensioning

An overly loose belt will, upon motor start, produce a slippage 'squeel' and cause premature belt failure and or intermittent airflow. An overly tight belt can cause premature motor or blower bearing failure.

Sheave and Pulley Alignment

Verify belt is straight; misalignment will cause premature belt failure. Adjust sheave if needed.

Belt Tensioning Procedure - HKV

Blower motors for HKV models are slide base mounted.

To adjust the belt tension:

1. Loosen the four (4) bolts that lock the base to the slide rails.
2. Insert a socket into the opening at the front of the base assembly.
3. Turn counter clock wise to tighten or clock wise to loosen the belt.
4. The belt should be tensioned using a tension gauge method such as the Browning Belt Tensioner to set proper belt tension (see next page).
5. After belt tension is set secure the (4) locking bolts.

Notes:

- Motor position should not need adjustment.
- Motor sheave position is at mid position of each sheave. Thus the motor sheave is typically 2.5 turns open on a 5 turn sheave.

Special Note for AHRI Testing

- Note 1: All HKV084 ratings @ 2800CFM (1321 l/s) w/21GPM (1.33 l/s). Sheave setting for AHRI is 3.5 turns open.
- Note 2: All HKV096 ratings @ 3200CFM (1510 l/s) w/24GPM (1.51 l/s). Sheave setting for AHRI is 3.0 turns open.
- Note 3: All HKV120 ratings @ 4000CFM (1888 l/s) w/30GPM (1.89 l/s). Sheave setting for AHRI is 2.5 turns open.
- Note 4: Cooling capacities based upon 80.6°F DB, 66.2°F WB entering air temperature.
- Note 5: Heating capacities based upon 68°F DB, 59°F WB entering air temperature.
- Note 6: All ratings based upon operation at lower voltage of dual voltage rated models.

Tensioning V-Belt Drives

General Rules of Tensioning

1. Ideal tension is the lowest tension at which the belt will not slip under peak load conditions.
2. Check tension frequently during the first 24-48 hours of operation.
3. Over tensioning shortens belt and bearing life.
4. Keep belts free from foreign material which may cause slip.
5. Make V-drive inspection on periodic basis. Tension when slipping. Never apply belt dressing as this will damage the belt and cause early failure.

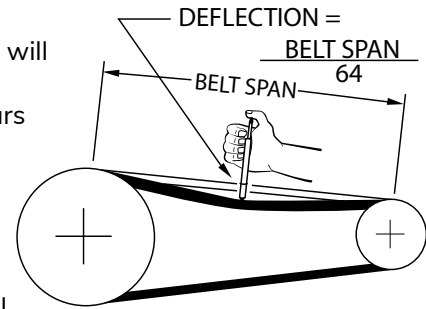

Tension Measurement Procedure

1. Measure the belt span (see sketch).
2. Position bottom of the large "O" ring on the span scale at the measured belt span.
3. Set the small "O" ring on the deflection force scale to zero.
4. Place the tension checker squarely on one belt at the center of the belt span. Apply a force on the plunger and perpendicular to the belt span until the bottom of the large "O" ring is even with the top of the next belt or with the bottom of a straight edge laid across the sheaves.
5. Remove the tension checker and read the force applied from the bottom of the small "O" ring on the deflection force scale.
6. Compare the force you have applied with the values given in the table below. The force should be between the minimum and maximum shown. The maximum value is shown for "New Belt" and new belts should be tensioned at this value to allow for expected tension loss. Used belts should be maintained at the minimum value as indicated in the table below.

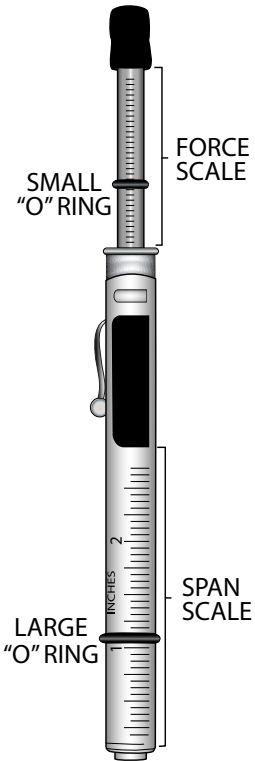

NOTE: The ratio of deflection to belt span is 1:64.

| Cross Section | Smallest Sheave Diameter Range | RPM Range | Belt Deflection Force | | | |
|---------------|--------------------------------|----------------------------|---|----------|---------------------------------------|----------|
| | | | Super Gripbelts and Unnotched Gripbands | | Gripnotch Belts and Notched Gripbands | |
| | | | Used Belt | New Belt | Used Belt | New Belt |
| A, AX | 7.6 - 9.1 | 1000 - 2500 2501 - 4000 | 16.458 | 24.464 | 18.237 | 27.133 |
| | | | 12.454 | 18.682 | 15.123 | 22.240 |
| | 9.6 - 12.2 | 1000 - 2500 2501 - 4000 | 20.016 | 30.246 | 22.240 | 32.915 |
| B, BX | 8.6 - 10.7 | 860 - 2500 2501 - 4000 | 16.902 | 25.354 | 19.126 | 28.467 |
| | | | 24.019 | 35.584 | 25.354 | 41.811 |
| | 12.7 - 17.8 | 1000 - 2500 2501 - 4000 | 20.906 | 31.136 | 22.685 | 33.805 |
| B, BX | 11.2 - 14.2 | 860 - 2500 2501 - 4000 | - | - | 21.795 | 32.026 |
| | | | 23.574 | 35.139 | 36.029 | 46.704 |
| | 14.7 - 21.8 | 860 - 2500 2501 - 4000 | 28.022 | 41.811 | 37.808 | 56.045 |
| | | | 26.688 | 39.587 | 32.470 | 48.483 |

Blower Sheave Information

Table 4a: HKV Blower Sheave and Belt Information

| Model | Configuration Return/Supply | Component | Drive Package | | | | |
|-------|---|--|---|---|--|---|--|
| | | | A | B | C | D | E |
| 084 | Back or Front/Top Back/Front Front/Back | Blower Sheave Motor Sheave Motor Belt | BK95 X 1" 1VP40 X 7/8" 1HP BX79 | BK110 X 1" 1VP34 X 7/8" 1HP BX81 | BK95 X 1" 1VP50 X 7/8" 1HP BX81 | BK95 X 1" 1VP40 X 7/8" 1.5HP BX79 | BK95 X 1" 1VP50 X 7/8" 1.5HP BX81 |
| 096 | | Blower Sheave Motor Sheave Motor Belt | BK95 X 1" 1VP40 X 7/8" 1.5HP BX79 | BK110 X 1" 1VP34 X 7/8" 1.5HP BX81 | BK95 X 1" 1VP50 X 7/8" 1.5HP BX81 | BK95 X 1" 1VP40 X 7/8" 2HP BX79 | BK95 X 1" 1VP50 X 7/8" 2HP BX81 |
| 120 | | Blower Sheave Motor Sheave Motor Belt | BK95 X 1" 1VP44 X 7/8" 2HP BX80 | BK110 X 1" 1VP40 X 7/8" 2HP BX81 | BK95 X 1" 1VP60 X 7/8" 2HP BX82 | BK95 X 1" 1VP44 X 7/8" 3HP BX80 | BK95 X 1" 1VP60 X 7/8" 3HP BX82 |
| 150 | | Blower Sheave Motor Sheave Motor Belt | BK95 X 1" 1VP50 X 7/8" 3HP BX81 | BK110 X 1" 1VP50 X 7/8" 3HP BX83 | BK95 X 1" 1VP62 X 7/8" 3HP BX83 | BK95 X 1" 1VP50 X 1-1/8" 5HP BX77 | BK95 X 1" 1VP65 X 1-1/8" 5HP H,F - BX79 N - BX81 |
| 168 | | Blower Sheave Motor Sheave Motor Belt | BK95H X 1-3/16" 1VP44 X 7/8" 2HP BX80 | BK110H X 1-3/16" 1VP40 X 7/8" 2HP BX82 | BK95H X 1-3/16" 1VP50 X 7/8" 2HP BX81 | BK95H X 1-3/16" 1VP44 X 7/8" 3HP BX80 | BK95H X 1-3/16" 1VP50 X 7/8" 3HP BX81 |
| 192 | Back or Front/Top Back/Front Front/Back | Blower Sheave Motor Sheave Motor Belt | BK95H X 1-3/16" 1VP44 X 7/8" 3HP BX80 | BK110H X 1-3/16" 1VP40 X 7/8" 3HP BX82 | BK95H X 1-3/16" 1VP50 X 7/8" 3HP BX81 | BK95H X 1-3/16" 1VP44 X 1-1/8" 5HP BX76 | BK95H X 1-3/16" 1VP50 X 1-1/8" 5HP BX77 |
| 240 | | Blower Sheave Motor Sheave Motor Belt | BK90H X 1-3/16" 1VP44 X 1-1/8" 5HP H,F - BX78 N - BX77 | BK110H X 1-3/16" 1VP44 X 1-1/8" 5HP BX80 | BK95H X 1-3/16" 1VP60 X 1-1/8" 5HP H,F - BX80 N - BX78 | N/A | BK95H X 1-3/16" 1VP60 X 1-3/8" 7.5HP H,F - BX79 N - BX78 |
| 300 | | Blower Sheave Motor Sheave Motor Belt | BK105H X 1-3/16" 1VP60 X 1-1/8" 5HP H,F - BX82 N - BX80 | BK110H X 1-3/16" 1VP50 X 1-1/8" 5HP BX80 | BK95H X 1-3/16" 1VP60 X 1-1/8" 5HP BX78 | BK105H X 1-3/16" 1VP60 X 1-3/8" 7.5HP BX80 | BK95H X 1-3/16" 1VP60 X 1-3/8" 7.5HP BX78 |

Note 1: D-drive is not available because standard sheave is not available in 1-3/8".

Blower Performance

HKV 084 Blower Performance

All Data is Wet Coil

| Airflow (SCFM) | ESP | Airflow (cfm) at External Static Pressure (in. wg) | | | | | | | | | | | | | | | | |
|----------------|------------|--|-------|------|------|------|------|------|------|------|------|------|------|------|------|------|------|--|
| | | 0.00 | 0.10 | 0.20 | 0.30 | 0.40 | 0.50 | 0.60 | 0.70 | 0.80 | 0.90 | 1.00 | 1.10 | 1.20 | 1.30 | 1.40 | 1.50 | |
| 2100 | BHP | 0.24 | 0.29 | 0.34 | 0.37 | 0.41 | 0.44 | 0.49 | 0.54 | 0.59 | 0.64 | 0.69 | 0.74 | 0.79 | 0.84 | 0.89 | 0.94 | |
| | Sheave/Mtr | B | B | B | A | A | A | A | A | A | C | C | C | C | C | C | C | |
| | RPM | 410 | 457 | 499 | 537 | 577 | 612 | 647 | 678 | 710 | 737 | 764 | 791 | 815 | 838 | | | |
| | Turns Open | 5 | 3.5 | 4.5 | 6 | 5 | 4 | 3 | 2.5 | 1.5 | 6 | 5.5 | 4.5 | 4 | 3 | | | |
| 2200 | BHP | 0.28 | 0.315 | 0.34 | 0.39 | 0.44 | 0.49 | 0.54 | 0.59 | 0.64 | 0.69 | 0.74 | 0.79 | 0.84 | 0.89 | 0.94 | 0.99 | |
| | Sheave/Mtr | B | B | B | A | A | A | A | A | A | C | C | C | C | C | C | C | |
| | RPM | 424 | 467 | 507 | 548 | 584 | 621 | 653 | 684 | 716 | 743 | 772 | 797 | 821 | 847 | | | |
| | Turns Open | 4.5 | 3.5 | 4.5 | 5.5 | 5 | 4 | 3 | 2 | 1.5 | 6 | 5 | 4.5 | 3.5 | 3 | | | |
| 2300 | BHP | 0.29 | 0.34 | 0.39 | 0.44 | 0.49 | 0.54 | 0.59 | 0.64 | 0.69 | 0.74 | 0.79 | 0.84 | 0.89 | 0.94 | 0.99 | | |
| | Sheave/Mtr | B | B | B | A | A | A | A | A | A | C | C | C | C | C | C | | |
| | RPM | 435 | 476 | 518 | 555 | 590 | 627 | 659 | 692 | 721 | 751 | 777 | 803 | 829 | 853 | | | |
| | Turns Open | 4.5 | 3 | 4 | 5.5 | 4.5 | 3.5 | 2.5 | 2 | 1.5 | 5.5 | 5 | 4 | 3.5 | 2.5 | | | |
| 2400 | BHP | 0.29 | 0.34 | 0.39 | 0.44 | 0.49 | 0.54 | 0.59 | 0.64 | 0.69 | 0.74 | 0.79 | 0.84 | 0.89 | 0.94 | 0.99 | | |
| | Sheave/Mtr | B | B | B | A | A | A | A | A | A | C | C | C | C | C | C | | |
| | RPM | 403 | 446 | 485 | 527 | 563 | 600 | 633 | 665 | 697 | 726 | 756 | 783 | 811 | 835 | 858 | | |
| | Turns Open | 5 | 4 | 3 | 6 | 5.5 | 4.5 | 3.5 | 2.5 | 1.5 | 1 | 5.5 | 4.5 | 4 | 3 | 2.5 | | |
| 2500 | BHP | 0.31 | 0.34 | 0.39 | 0.44 | 0.49 | 0.54 | 0.59 | 0.64 | 0.74 | 0.79 | 0.84 | 0.89 | 0.94 | 0.99 | 1.04 | | |
| | Sheave/Mtr | B | B | B | A | A | A | A | A | A | C | C | C | C | C | E | | |
| | RPM | 411 | 452 | 495 | 532 | 567 | 604 | 636 | 670 | 700 | 729 | 759 | 786 | 813 | 838 | 864 | | |
| | Turns Open | 5 | 4 | 2.5 | 6 | 5.5 | 4 | 3.5 | 2.5 | 1.5 | 1 | 5.5 | 4.5 | 3.5 | 3 | 2.5 | | |
| 2600 | BHP | 0.34 | 0.43 | 0.48 | 0.53 | 0.58 | 0.63 | 0.68 | 0.73 | 0.78 | 0.83 | 0.88 | 0.93 | 1.03 | 1.08 | 1.13 | | |
| | Sheave/Mtr | B | B | B | A | A | A | A | A | A | C | C | C | C | C | E | | |
| | RPM | 420 | 460 | 500 | 536 | 570 | 606 | 638 | 671 | 701 | 729 | 759 | 786 | 814 | 839 | 865 | | |
| | Turns Open | 4.5 | 3.5 | 2.5 | 6 | 5 | 4 | 3 | 2 | 1.5 | 1 | 5 | 4 | 4 | 3 | 2.5 | | |
| 2700 | BHP | 0.38 | 0.43 | 0.48 | 0.53 | 0.59 | 0.64 | 0.69 | 0.74 | 0.79 | 0.84 | 0.89 | 0.94 | 1.04 | 1.09 | 1.14 | | |
| | Sheave/Mtr | B | B | B | A | A | A | A | A | A | C | C | C | E | E | E | | |
| | RPM | 423 | 463 | 504 | 539 | 576 | 609 | 641 | 674 | 703 | 734 | 762 | 788 | 816 | 841 | 867 | | |
| | Turns Open | 4.5 | 3.5 | 2 | 5.5 | 5 | 4 | 3 | 2 | 1.5 | 1 | 5 | 4 | 4 | 3 | 2.5 | | |
| 2800 | BHP | 0.39 | 0.44 | 0.49 | 0.54 | 0.64 | 0.69 | 0.74 | 0.79 | 0.84 | 0.89 | 0.94 | 1.04 | 1.09 | 1.12 | 1.22 | | |
| | Sheave/Mtr | B | B | B | A | A | A | A | A | A | C | C | E | E | E | E | | |
| | RPM | 431 | 474 | 510 | 545 | 581 | 613 | 647 | 677 | 706 | 737 | 764 | 793 | 818 | 843 | 869 | | |
| | Turns Open | 4.5 | 3 | 2 | 5.5 | 5 | 4 | 3 | 2 | 1.5 | 5.5 | 1 | 4.5 | 4 | 3 | 2.5 | | |
| 2900 | BHP | 0.44 | 0.49 | 0.54 | 0.59 | 0.64 | 0.74 | 0.79 | 0.84 | 0.89 | 0.94 | 1.04 | 1.09 | 1.14 | 1.19 | 1.24 | | |
| | Sheave/Mtr | B | B | B | A | A | A | A | A | A | C | E | E | E | E | E | | |
| | RPM | 440 | 481 | 517 | 551 | 586 | 618 | 651 | 681 | 710 | 740 | 767 | 795 | 821 | 845 | 872 | | |
| | Turns Open | 4 | 3 | 2 | 5.5 | 4.5 | 3.5 | 2.5 | 1.5 | 1 | 5.5 | 5.5 | 4.5 | 3.5 | 3 | 2 | | |
| 3000 | BHP | 0.43 | 0.49 | 0.54 | 0.59 | 0.64 | 0.69 | 0.74 | 0.84 | 0.89 | 0.94 | 1.04 | 1.09 | 1.14 | 1.19 | 1.24 | 1.29 | |
| | Sheave/Mtr | B | B | B | A | A | A | A | A | A | D | E | E | E | E | E | | |
| | RPM | 412 | 455 | 492 | 526 | 563 | 595 | 628 | 658 | 687 | 718 | 745 | 774 | 800 | 826 | 852 | 876 | |
| | Turns Open | 5 | 3.5 | 2.5 | 6 | 5.5 | 4.5 | 3.5 | 2.5 | 1.5 | 1.5 | 1 | 5 | 4.5 | 3.5 | 3 | 2 | |
| 3100 | BHP | 0.44 | 0.53 | 0.59 | 0.64 | 0.69 | 0.74 | 0.84 | 0.89 | 0.94 | 0.99 | 1.04 | 1.14 | 1.19 | 1.24 | 1.34 | 1.39 | |
| | Sheave/Mtr | B | B | B | A | A | A | A | A | A | D | E | E | E | E | E | | |
| | RPM | 421 | 459 | 499 | 533 | 569 | 600 | 633 | 663 | 691 | 722 | 749 | 777 | 803 | 828 | 854 | 878 | |
| | Turns Open | 4.5 | 3.5 | 2.5 | 6 | 5 | 4 | 3 | 2 | 1.5 | 1.5 | 1 | 5 | 4 | 3.5 | 2.5 | 2 | |
| 3200 | BHP | 0.49 | 0.54 | 0.64 | 0.69 | 0.74 | 0.84 | 0.89 | 0.94 | 0.99 | 1.04 | 1.14 | 1.19 | 1.24 | 1.34 | 1.39 | 1.44 | |
| | Sheave/Mtr | B | B | B | A | A | A | A | A | A | D | E | E | E | E | E | | |
| | RPM | 441 | 478 | 513 | 549 | 581 | 614 | 644 | 672 | 703 | 730 | 759 | 785 | 810 | 837 | 861 | 887 | |
| | Turns Open | 4 | 3 | 2 | 5.5 | 5 | 4 | 3 | 2 | 1.5 | 1.5 | 5.5 | 4.5 | 4 | 3 | 2.5 | 2 | |
| 3300 | BHP | 0.54 | 0.64 | 0.69 | 0.74 | 0.83 | 0.89 | 0.94 | 0.99 | 1.04 | 1.14 | 1.23 | 1.29 | 1.34 | 1.44 | 1.49 | | |
| | Sheave/Mtr | B | B | A | A | A | A | A | A | D | D | E | E | E | E | E | | |
| | RPM | 456 | 495 | 529 | 561 | 595 | 625 | 656 | 685 | 712 | 741 | 767 | 795 | 820 | 844 | 870 | | |
| | Turns Open | 3.5 | 2.5 | 6 | 5 | 4.5 | 3.5 | 2.5 | 2 | 1.5 | 1 | 5 | 4.5 | 3.5 | 3 | 2.5 | | |
| 3400 | BHP | 0.63 | 0.69 | 0.74 | 0.79 | 0.84 | 0.94 | 0.99 | 1.04 | 1.14 | 1.19 | 1.24 | 1.34 | 1.44 | 1.49 | | | |
| | Sheave/Mtr | B | B | A | A | A | A | A | D | 1.5 | D | E | E | E | E | | | |
| | RPM | 471 | 506 | 539 | 574 | 604 | 633 | 664 | 692 | 721 | 747 | 773 | 800 | 825 | 851 | | | |
| | Turns Open | 3 | 2 | 5.5 | 5 | 4 | 3.5 | 2.5 | 2 | 1.5 | 1 | 5 | 4 | 3.5 | 2.5 | | | |
| 3500 | BHP | 0.64 | 0.74 | 0.79 | 0.84 | 0.94 | 0.99 | 1.04 | 1.14 | 1.23 | 1.29 | 1.34 | 1.44 | 1.49 | | | | |
| | Sheave/Mtr | B | A | A | A | A | A | D | D | D | E | E | E | E | | | | |
| | RPM | 486 | 520 | 555 | 586 | 615 | 647 | 674 | 704 | 730 | 756 | 784 | 808 | 835 | | | | |
| | Turns Open | 2.5 | 6 | 5.5 | 4.5 | 4 | 3 | 2.5 | 1.5 | 1 | 5.5 | 4.5 | 4 | 3 | | | | |

A = Standard Static/Standard Motor, B = Low Static/Standard Motor, C = High Static/Standard Motor, D = Standard Static/Large Motor, E = High Static/Large Motor
 Unit factory shipped with standard static sheave and drive at 2.5 turns open. Other speed require field selection.
 For applications requiring higher static pressures, contact your local representative. Performance data does not include drive losses and is based on sea level conditions.
 Do not operate in black regions. All airflow in rated at lowest Voltage if unit is dual Voltage rated, i.e. 208V for 208-230V units.

Blower Performance, Cont'd.

HKV 096 Blower Performance

All Data is Wet Coil

| Airflow (SCFM) | ESP | Airflow (cfm) at External Static Pressure (in. wg) | | | | | | | | | | | | | | | | |
|----------------|------------|--|------|------|------|------|------|------|------|------|------|------|------|------|------|------|------|-----|
| | | 0.00 | 0.10 | 0.20 | 0.30 | 0.40 | 0.50 | 0.60 | 0.70 | 0.80 | 0.90 | 1.00 | 1.10 | 1.20 | 1.30 | 1.40 | 1.50 | |
| 2400 | BHP | | 0.29 | 0.34 | 0.39 | 0.44 | 0.49 | 0.54 | 0.59 | 0.64 | 0.69 | 0.74 | 0.79 | 0.84 | 0.89 | 0.94 | 0.99 | |
| | Sheave/Mtr | | B | B | B | A | A | A | A | A | A | A | C | C | C | C | C | |
| | RPM | | 403 | 446 | 485 | 527 | 563 | 600 | 633 | 665 | 697 | 726 | 756 | 783 | 811 | 835 | 858 | |
| | Turns Open | | 5 | 4 | 3 | 6 | 5.5 | 4.5 | 3.5 | 2.5 | 1.5 | 1 | 5.5 | 5 | 4 | 3.5 | 3 | |
| 2500 | BHP | | 0.31 | 0.34 | 0.39 | 0.44 | 0.49 | 0.54 | 0.59 | 0.64 | 0.74 | 0.79 | 0.84 | 0.89 | 0.94 | 0.99 | 1.04 | |
| | Sheave/Mtr | | B | B | B | A | A | A | A | A | A | A | C | C | C | C | C | |
| | RPM | | 411 | 452 | 495 | 532 | 567 | 604 | 636 | 670 | 700 | 729 | 759 | 786 | 813 | 838 | 864 | |
| | Turns Open | | 5 | 4 | 2.5 | 6 | 5.5 | 4 | 3.5 | 2.5 | 1.5 | 1 | 5.5 | 5 | 4 | 3 | 3 | |
| 2600 | BHP | | 0.34 | 0.43 | 0.48 | 0.53 | 0.58 | 0.63 | 0.68 | 0.73 | 0.78 | 0.83 | 0.88 | 0.93 | 1.03 | 1.08 | 1.13 | |
| | Sheave/Mtr | | B | B | B | A | A | A | A | A | A | A | C | C | C | C | C | |
| | RPM | | 420 | 460 | 500 | 536 | 570 | 606 | 638 | 671 | 701 | 729 | 759 | 786 | 814 | 839 | 865 | |
| | Turns Open | | 4.5 | 3.5 | 2.5 | 6 | 5 | 4 | 3 | 2 | 1.5 | 1 | 5 | 5 | 4 | 3 | 2.5 | |
| 2700 | BHP | | 0.38 | 0.43 | 0.48 | 0.53 | 0.59 | 0.64 | 0.69 | 0.74 | 0.79 | 0.84 | 0.89 | 0.94 | 1.04 | 1.09 | 1.14 | |
| | Sheave/Mtr | | B | B | B | A | A | A | A | A | A | A | C | C | C | C | C | |
| | RPM | | 423 | 463 | 504 | 539 | 576 | 609 | 641 | 674 | 703 | 734 | 762 | 788 | 816 | 841 | 867 | |
| | Turns Open | | 4.5 | 3.5 | 2 | 5.5 | 5 | 4 | 3 | 2 | 1.5 | 1 | 5 | 4.5 | 4 | 3 | 2.5 | |
| 2800 | BHP | | 0.39 | 0.44 | 0.49 | 0.54 | 0.64 | 0.69 | 0.74 | 0.79 | 0.84 | 0.89 | 0.94 | 1.04 | 1.09 | 1.12 | 1.22 | |
| | Sheave/Mtr | | B | B | B | A | A | A | A | A | A | C | C | C | C | C | C | |
| | RPM | | 431 | 474 | 510 | 545 | 581 | 613 | 647 | 677 | 706 | 737 | 764 | 793 | 818 | 843 | 869 | |
| | Turns Open | | 4.5 | 3 | 2 | 5.5 | 5 | 4 | 3 | 2 | 1.5 | 5.5 | 5 | 4.5 | 3.5 | 3 | 2.5 | |
| 2900 | BHP | | 0.44 | 0.49 | 0.54 | 0.59 | 0.64 | 0.74 | 0.79 | 0.84 | 0.89 | 0.94 | 1.04 | 1.09 | 1.14 | 1.19 | 1.24 | |
| | Sheave/Mtr | | B | B | B | A | A | A | A | A | A | | C | C | C | C | C | |
| | RPM | | 440 | 481 | 517 | 551 | 586 | 618 | 651 | 681 | 710 | 740 | 767 | 795 | 821 | 845 | 872 | |
| | Turns Open | | 4 | 3 | 2 | 5.5 | 4.5 | 3.5 | 2.5 | 1.5 | 1 | 5.5 | 5 | 4.5 | 3.5 | 2.5 | 2.5 | |
| 3000 | BHP | 0.43 | 0.49 | 0.54 | 0.59 | 0.64 | 0.69 | 0.74 | 0.84 | 0.89 | 0.94 | 1.04 | 1.09 | 1.14 | 1.19 | 1.24 | 1.29 | |
| | Sheave/Mtr | | B | B | B | A | A | A | A | A | A | A | C | C | C | C | C | |
| | RPM | | 412 | 455 | 492 | 526 | 563 | 595 | 628 | 658 | 687 | 718 | 745 | 774 | 800 | 826 | 852 | 876 |
| | Turns Open | | 5 | 3.5 | 2.5 | 6 | 5.5 | 4.5 | 3.5 | 2.5 | 1.5 | 1.5 | 6 | 5 | 4 | 3.5 | 2.5 | 2 |
| 3100 | BHP | 0.44 | 0.53 | 0.59 | 0.64 | 0.69 | 0.74 | 0.84 | 0.89 | 0.94 | 0.99 | 1.04 | 1.14 | 1.19 | 1.24 | 1.34 | 1.39 | |
| | Sheave/Mtr | | B | B | B | A | A | A | A | A | A | A | C | C | C | C | C | |
| | RPM | | 421 | 459 | 499 | 533 | 569 | 600 | 633 | 663 | 691 | 722 | 749 | 777 | 803 | 828 | 854 | 878 |
| | Turns Open | | 4.5 | 3.5 | 2.5 | 6 | 5 | 4 | 3 | 2 | 1.5 | 1.5 | 6 | 4.5 | 4 | 3 | 2.5 | 2 |
| 3200 | BHP | 0.49 | 0.54 | 0.64 | 0.69 | 0.74 | 0.84 | 0.89 | 0.94 | 0.99 | 1.04 | 1.14 | 1.19 | 1.24 | 1.34 | 1.39 | 1.44 | |
| | Sheave/Mtr | | B | B | B | A | A | A | A | A | A | C | C | C | C | C | C | |
| | RPM | | 441 | 478 | 513 | 549 | 581 | 614 | 644 | 672 | 703 | 730 | 759 | 785 | 810 | 837 | 861 | 887 |
| | Turns Open | | 4 | 3 | 2 | 5.5 | 5 | 4 | 3 | 2 | 1.5 | 1.5 | 5.5 | 4.5 | 4 | 3 | 2.5 | 2 |
| 3300 | BHP | 0.54 | 0.64 | 0.69 | 0.74 | 0.83 | 0.89 | 0.94 | 0.99 | 1.04 | 1.14 | 1.23 | 1.29 | 1.34 | 1.44 | 1.49 | 1.54 | |
| | Sheave/Mtr | | B | B | A | A | A | A | A | A | A | C | C | C | C | C | E | |
| | RPM | | 456 | 495 | 529 | 561 | 595 | 625 | 656 | 685 | 712 | 741 | 767 | 795 | 820 | 844 | 870 | 893 |
| | Turns Open | | 3.5 | 2.5 | 6 | 5 | 4.5 | 3.5 | 2.5 | 2 | 1.5 | 1 | 5 | 4.5 | 3.5 | 3 | 2 | 2 |
| 3400 | BHP | 0.63 | 0.69 | 0.74 | 0.79 | 0.84 | 0.94 | 0.99 | 1.04 | 1.14 | 1.19 | 1.24 | 1.34 | 1.44 | 1.49 | 1.54 | 1.64 | |
| | Sheave/Mtr | | B | B | A | A | A | A | A | A | A | C | C | C | C | E | E | |
| | RPM | | 471 | 506 | 539 | 574 | 604 | 633 | 664 | 692 | 721 | 747 | 773 | 800 | 825 | 851 | 875 | 898 |
| | Turns Open | | 3 | 2 | 5.5 | 5 | 4 | 3.5 | 2.5 | 2 | 1.5 | 1 | 5 | 4 | 3.5 | 2.5 | 2.5 | 2 |
| 3500 | BHP | 0.64 | 0.74 | 0.79 | 0.84 | 0.94 | 0.99 | 1.04 | 1.14 | 1.23 | 1.29 | 1.34 | 1.44 | 1.49 | 1.54 | 1.64 | 1.74 | |
| | Sheave/Mtr | | B | A | A | A | A | A | A | A | C | C | C | C | E | E | E | |
| | RPM | | 486 | 520 | 555 | 586 | 615 | 647 | 674 | 704 | 730 | 756 | 784 | 808 | 835 | 858 | 883 | 906 |
| | Turns Open | | 2.5 | 6 | 5.5 | 4.5 | 4 | 3 | 2.5 | 1.5 | 1 | 5.5 | 4.5 | 4 | 3 | 2.5 | 2.5 | 1.5 |
| 3600 | BHP | 0.74 | 0.79 | 0.84 | 0.94 | 0.99 | 1.04 | 1.14 | 1.19 | 1.24 | 1.34 | 1.44 | 1.49 | 1.54 | 1.64 | 1.74 | 1.83 | |
| | Sheave/Mtr | | B | A | A | A | A | A | A | A | C | C | C | E | E | E | E | |
| | RPM | | 495 | 528 | 562 | 593 | 624 | 652 | 680 | 708 | 734 | 762 | 787 | 812 | 838 | 861 | 886 | 909 |
| | Turns Open | | 2.5 | 6 | 5 | 4.5 | 3.5 | 3 | 2 | 1.5 | 1 | 5.5 | 4.5 | 4 | 3 | 2.5 | 2.5 | 1.5 |

A = Standard Static/Standard Motor, B = Low Static/Standard Motor, C = High Static/Standard Motor, D = Standard Static/Large Motor, E = High Static/Large Motor
 Unit factory shipped with standard static sheave and drive at 2.5 turns open. Other speed require field selection.
 For applications requiring higher static pressures, contact your local representative. Performance data does not include drive losses and is based on sea level conditions. Do not operate in black regions. All airflow in rated at lowest Voltage if unit is dual Voltage rated, i.e. 208V for 208-230V units.

Table Continued on Next Page

Blower Performance, Cont'd.

Table Continued from Previous Page

All Data is Wet Coil

| Airflow (SCFM) | ESP | Airflow (cfm) at External Static Pressure (in. wg) | | | | | | | | | | | | | | | |
|----------------|------------|--|------|------|------|------|------|------|------|------|------|------|------|------|------|------|------|
| | | 0.00 | 0.10 | 0.20 | 0.30 | 0.40 | 0.50 | 0.60 | 0.70 | 0.80 | 0.90 | 1.00 | 1.10 | 1.20 | 1.30 | 1.40 | 1.50 |
| 3700 | BHP | 0.79 | 0.84 | 0.93 | 0.99 | 1.04 | 1.14 | 1.19 | 1.24 | 1.34 | 1.44 | 1.49 | 1.54 | 1.64 | 1.74 | 1.79 | 1.84 |
| | Sheave/Mtr | B | A | A | A | A | A | A | A | A | C | C | E | E | E | E | E |
| | RPM | 506 | 541 | 572 | 605 | 633 | 661 | 690 | 716 | 744 | 769 | 793 | 820 | 843 | 868 | 891 | 913 |
| | Turns Open | 2 | 5.5 | 5 | 4 | 3.5 | 3 | 2 | 1.5 | 1 | 5 | 4.5 | 3.5 | 3 | 2.5 | 2 | 1.5 |
| 3800 | BHP | 0.84 | 0.89 | 0.94 | 1.04 | 1.13 | 1.19 | 1.24 | 1.34 | 1.43 | 1.49 | 1.54 | 1.64 | 1.73 | 1.79 | 1.84 | 1.94 |
| | Sheave/Mtr | B | A | A | A | A | A | A | A | C | C | E | E | E | E | E | E |
| | RPM | 515 | 549 | 580 | 611 | 640 | 667 | 696 | 721 | 749 | 773 | 798 | 823 | 847 | 872 | 894 | 918 |
| | Turns Open | 2 | 5.5 | 4.5 | 4 | 3.5 | 2.5 | 1.5 | 1.5 | 5.5 | 5 | 4 | 3.5 | 3 | 2.5 | 2 | 1 |
| 3900 | BHP | 0.89 | 0.94 | 1.04 | 1.09 | 1.14 | 1.24 | 1.34 | 1.39 | 1.44 | 1.54 | 1.64 | 1.69 | 1.74 | 1.84 | 1.94 | |
| | Sheave/Mtr | A | A | A | A | A | A | A | A | C | E | E | E | E | E | E | |
| | RPM | 525 | 556 | 586 | 617 | 645 | 674 | 701 | 726 | 753 | 778 | 804 | 827 | 850 | 875 | 897 | |
| | Turns Open | 6 | 5.5 | 4.5 | 4 | 3 | 2.5 | 1.5 | 1 | 5.5 | 5 | 4 | 3.5 | 2.5 | 2 | 2 | |
| 4000 | BHP | 0.94 | 1.04 | 1.09 | 1.14 | 1.24 | 1.34 | 1.44 | 1.49 | 1.54 | 1.64 | 1.74 | 1.79 | 1.84 | 1.94 | | |
| | Sheave/Mtr | A | A | A | A | A | A | A | A | E | E | E | E | E | E | | |
| | RPM | 539 | 569 | 601 | 629 | 659 | 685 | 711 | 738 | 763 | 789 | 812 | 835 | 860 | 882 | | |
| | Turns Open | 5.5 | 5 | 4.5 | 3.5 | 3 | 2 | 1 | 1 | 5 | 4.5 | 3.5 | 3 | 2.5 | 2 | | |

A = Standard Static/Standard Motor, B = Low Static/Standard Motor, C = High Static/Standard Motor, D = Standard Static/Large Motor, E = High Static/Large Motor
 Unit factory shipped with standard static sheave and drive at 2.5 turns open. Other speed require field selection.
 For applications requiring higher static pressures, contact your local representative. Performance data does not include drive losses and is based on sea level conditions.
 Do not operate in black regions. All airflow in rated at lowest Voltage if unit is dual Voltage rated, i.e. 208V for 208-230V units.

Blower Performance, Cont'd.

HKV 120 Blower Performance

All Data is Wet Coil

| Airflow (SCFM) | ESP | Airflow (cfm) at External Static Pressure (in. wg) | | | | | | | | | | | | | | | |
|----------------|------------|--|------|------|------|------|------|------|------|------|------|------|------|------|------|------|------|
| | | 0.00 | 0.10 | 0.20 | 0.30 | 0.40 | 0.50 | 0.60 | 0.70 | 0.80 | 0.90 | 1.00 | 1.10 | 1.20 | 1.30 | 1.40 | 1.50 |
| 3000 | BHP | | | 0.54 | 0.59 | 0.64 | 0.69 | 0.74 | 0.84 | 0.89 | 0.94 | 1.04 | 1.09 | 1.14 | 1.19 | 1.24 | 1.34 |
| | Sheave/Mtr | | | B | B | B | B | A | A | A | A | A | A | A | A | C | C |
| | RPM | | | 491 | 529 | 563 | 595 | 626 | 659 | 689 | 717 | 745 | 774 | 801 | 826 | 851 | 877 |
| | Turns Open | | | 5 | 4 | 3 | 2 | 6 | 5 | 4 | 3.5 | 3 | 2 | 1.5 | 1 | 6 | 5.5 |
| 3100 | BHP | 0.54 | 0.59 | 0.64 | 0.69 | 0.74 | 0.84 | 0.89 | 0.94 | 1.04 | 1.09 | 1.14 | 1.19 | 1.24 | 1.34 | 1.44 | |
| | Sheave/Mtr | B | B | B | B | A | A | A | A | A | A | A | A | C | C | C | |
| | RPM | 469 | 504 | 542 | 575 | 607 | 637 | 670 | 699 | 726 | 754 | 783 | 809 | 834 | 859 | 884 | |
| | Turns Open | 5.5 | 5 | 3.5 | 2.5 | 6 | 5.5 | 4.5 | 4 | 3.5 | 2.5 | 2 | 1.5 | 6 | 5 | 5 | |
| 3200 | BHP | 0.59 | 0.64 | 0.69 | 0.74 | 0.84 | 0.89 | 0.94 | 1.04 | 1.09 | 1.14 | 1.24 | 1.29 | 1.34 | 1.44 | 1.53 | |
| | Sheave/Mtr | B | B | B | B | A | A | A | A | A | A | A | A | C | C | C | |
| | RPM | 485 | 520 | 556 | 588 | 619 | 649 | 680 | 708 | 736 | 765 | 791 | 817 | 841 | 868 | 891 | |
| | Turns Open | 5 | 4.5 | 3 | 2 | 6 | 5 | 4.5 | 3.5 | 3 | 2.5 | 1.5 | 1 | 6 | 5.5 | 5 | |
| 3300 | BHP | 0.59 | 0.64 | 0.69 | 0.74 | 0.84 | 0.89 | 0.94 | 1.04 | 1.09 | 1.14 | 1.24 | 1.29 | 1.34 | 1.44 | 1.49 | 1.54 |
| | Sheave/Mtr | B | B | B | B | A | A | A | A | A | A | A | A | C | C | C | |
| | RPM | 464 | 500 | 537 | 570 | 601 | 631 | 662 | 691 | 718 | 745 | 774 | 799 | 824 | 849 | 875 | 898 |
| | Turns Open | 6 | 5 | 4 | 2.5 | 2 | 5.5 | 5 | 4 | 3.5 | 2.5 | 2 | 1.5 | 1 | 5.5 | 5 | 4.5 |
| 3400 | BHP | 0.64 | 0.69 | 0.74 | 0.84 | 0.89 | 0.94 | 1.04 | 1.09 | 1.14 | 1.24 | 1.29 | 1.34 | 1.44 | 1.49 | 1.54 | 1.64 |
| | Sheave/Mtr | B | B | B | B | A | A | A | A | A | A | A | A | C | C | C | C |
| | RPM | 480 | 515 | 551 | 583 | 613 | 642 | 674 | 701 | 728 | 754 | 783 | 808 | 833 | 857 | 882 | 905 |
| | Turns Open | 5.5 | 4.5 | 3.5 | 2.5 | 6 | 5.5 | 4.5 | 3.5 | 3 | 2.5 | 2 | 1 | 6 | 5.5 | 5 | 4.5 |
| 3500 | BHP | 0.69 | 0.74 | 0.84 | 0.89 | 0.94 | 1.04 | 1.09 | 1.14 | 1.24 | 1.29 | 1.34 | 1.44 | 1.54 | 1.59 | 1.64 | 1.74 |
| | Sheave/Mtr | B | B | B | B | A | A | A | A | A | A | A | A | C | C | C | C |
| | RPM | 496 | 530 | 565 | 596 | 625 | 654 | 684 | 711 | 738 | 766 | 792 | 816 | 841 | 867 | 890 | 913 |
| | Turns Open | 5 | 4 | 3 | 2 | 6 | 5 | 4 | 3.5 | 3 | 2.5 | 1.5 | 1 | 6 | 5.5 | 5 | 4 |
| 3600 | BHP | 0.74 | 0.84 | 0.89 | 0.94 | 1.04 | 1.09 | 1.14 | 1.24 | 1.34 | 1.39 | 1.44 | 1.54 | 1.59 | 1.64 | 1.74 | 1.84 |
| | Sheave/Mtr | B | B | B | A | A | A | A | A | A | A | A | C | C | C | C | C |
| | RPM | 511 | 544 | 578 | 608 | 637 | 668 | 695 | 722 | 748 | 776 | 800 | 825 | 849 | 874 | 897 | 920 |
| | Turns Open | 4.5 | 3.5 | 2.5 | 6 | 5.5 | 4.5 | 4 | 3.5 | 2.5 | 2 | 1 | 6 | 6 | 5 | 4.5 | 4 |
| 3700 | BHP | 0.84 | 0.89 | 0.94 | 1.04 | 1.14 | 1.19 | 1.24 | 1.34 | 1.39 | 1.44 | 1.54 | 1.64 | 1.69 | 1.74 | 1.84 | 1.94 |
| | Sheave/Mtr | B | B | B | A | A | A | A | A | A | A | A | C | C | C | C | C |
| | RPM | 526 | 561 | 592 | 621 | 649 | 679 | 706 | 732 | 758 | 785 | 809 | 833 | 857 | 882 | 905 | 927 |
| | Turns Open | 4 | 3 | 2 | 6 | 5 | 4.5 | 3.5 | 3 | 2.5 | 1.5 | 1 | 6 | 5.5 | 5 | 4.5 | 4 |
| 3800 | BHP | 0.89 | 0.94 | 1.04 | 1.09 | 1.14 | 1.24 | 1.34 | 1.39 | 1.44 | 1.54 | 1.64 | 1.69 | 1.74 | 1.84 | 1.94 | 2.04 |
| | Sheave/Mtr | B | B | B | A | A | A | A | A | A | A | A | C | C | C | C | E |
| | RPM | 544 | 575 | 605 | 633 | 661 | 691 | 717 | 742 | 767 | 794 | 818 | 842 | 867 | 890 | 912 | 934 |
| | Turns Open | 3.5 | 2.5 | 1.5 | 5.5 | 5 | 4 | 3.5 | 2.5 | 2 | 1.5 | 1 | 6 | 5.5 | 4.5 | 4 | 3.5 |
| 3900 | BHP | 0.94 | 1.04 | 1.14 | 1.19 | 1.24 | 1.34 | 1.44 | 1.49 | 1.54 | 1.64 | 1.74 | 1.79 | 1.84 | 1.94 | 2.04 | 2.14 |
| | Sheave/Mtr | B | B | A | A | A | A | A | A | A | A | C | C | C | C | E | E |
| | RPM | 555 | 589 | 618 | 646 | 676 | 702 | 728 | 753 | 779 | 803 | 827 | 850 | 875 | 898 | 920 | 941 |
| | Turns Open | 3 | 2 | 6 | 5 | 4.5 | 3.5 | 3 | 2.5 | 2 | 1 | 6 | 5.5 | 5 | 4.5 | 4 | 3.5 |
| 4000 | BHP | 1.04 | 1.09 | 1.14 | 1.24 | 1.34 | 1.44 | 1.49 | 1.54 | 1.64 | 1.74 | 1.79 | 1.84 | 1.94 | 2.04 | 2.14 | 2.24 |
| | Sheave/Mtr | B | B | A | A | A | A | A | A | A | A | C | C | C | E | E | E |
| | RPM | 572 | 601 | 630 | 657 | 686 | 712 | 737 | 762 | 789 | 812 | 836 | 859 | 883 | 905 | 927 | 948 |
| | Turns Open | 2.5 | 2 | 5.5 | 5 | 4 | 3.5 | 3 | 2 | 1.5 | 1 | 6 | 5.5 | 5 | 4.5 | 4 | 3.5 |
| 4100 | BHP | 1.14 | 1.19 | 1.24 | 1.34 | 1.44 | 1.49 | 1.54 | 1.64 | 1.74 | 1.84 | 1.89 | 1.94 | 2.04 | 2.14 | 2.24 | 2.34 |
| | Sheave/Mtr | B | A | A | A | A | A | A | A | A | C | C | C | E | E | E | E |
| | RPM | 589 | 617 | 645 | 672 | 700 | 726 | 751 | 775 | 801 | 824 | 847 | 872 | 894 | 915 | 937 | 960 |
| | Turns Open | 2 | 6 | 5 | 4.5 | 4 | 3 | 2.5 | 2 | 1 | 6 | 5.5 | 5 | 4.5 | 4 | 3.5 | 3 |
| 4200 | BHP | 1.24 | 1.29 | 1.34 | 1.44 | 1.54 | 1.59 | 1.64 | 1.74 | 1.84 | 2 | 2.04 | 2.09 | 2.14 | 2.24 | 2.34 | 2.44 |
| | Sheave/Mtr | A | A | A | A | A | A | A | A | A | E | E | E | E | E | E | E |
| | RPM | 605 | 633 | 660 | 689 | 714 | 739 | 763 | 790 | 813 | 836 | 858 | 882 | 904 | 925 | 946 | 969 |
| | Turns Open | 6 | 5.5 | 5 | 4 | 3.5 | 2.5 | 2.5 | 1.5 | 1 | 6 | 5.5 | 5.5 | 4.5 | 4 | 3.5 | 3 |
| 4300 | BHP | 1.29 | 1.34 | 1.44 | 1.54 | 1.64 | 1.69 | 1.74 | 1.84 | 2 | 2.04 | 2.14 | 2.24 | 2.29 | 2.34 | 2.44 | 2.54 |
| | Sheave/Mtr | A | A | A | A | A | A | A | A | E | E | E | E | E | E | E | E |
| | RPM | 621 | 649 | 675 | 703 | 728 | 752 | 776 | 802 | 827 | 847 | 869 | 893 | 914 | 935 | 956 | 979 |
| | Turns Open | 6 | 5 | 4.5 | 3.5 | 3 | 2.5 | 2 | 1 | 6 | 6 | 5.5 | 5 | 4.5 | 4 | 3 | 2.5 |
| 4400 | BHP | 1.39 | 1.44 | 1.54 | 1.64 | 1.74 | 1.84 | 1.89 | 2 | 2.04 | 2.14 | 2.24 | 2.34 | 2.44 | 2.49 | 2.54 | 2.64 |
| | Sheave/Mtr | A | A | A | A | A | A | A | D | E | E | E | E | E | E | E | E |
| | RPM | 637 | 664 | 690 | 717 | 742 | 766 | 791 | 814 | 836 | 858 | 882 | 904 | 925 | 945 | 968 | 988 |
| | Turns Open | 5.5 | 4.5 | 4 | 3.5 | 2.5 | 2 | 1.5 | 1 | 6 | 5.5 | 5 | 4.5 | 4 | 3.5 | 3 | 2.5 |
| 4500 | BHP | 1.49 | 1.54 | 1.64 | 1.74 | 1.84 | 1.94 | 2.04 | 2.09 | 2.14 | 2.24 | 2.34 | 2.44 | 2.54 | 2.64 | 2.74 | 2.84 |
| | Sheave/Mtr | A | A | A | A | A | A | D | D | E | E | E | E | E | E | E | E |
| | RPM | 653 | 679 | 707 | 731 | 755 | 779 | 804 | 826 | 848 | 870 | 893 | 914 | 935 | 955 | 978 | 997 |
| | Turns Open | 5 | 4.5 | 3.5 | 3 | 2 | 1.5 | 1.5 | 1 | 6 | 5.5 | 5 | 4.5 | 4 | 3.5 | 2.5 | 2 |

A = Standard Static/Standard Motor, B = Low Static/Standard Motor, C = High Static/Standard Motor, D = Standard Static/Large Motor, E = High Static/Large Motor
 Unit factory shipped with standard static sheave and drive at 2.5 turns open. Other speed require field selection.
 For applications requiring higher static pressures, contact your local representative. Performance data does not include drive losses and is based on sea level conditions. Do not operate in black regions. All airflow in rated at lowest Voltage if unit is dual Voltage rated, i.e. 208V for 208-230V units.

Table Continued on Next Page

Blower Performance, Cont'd.

Table Continued from Previous Page

All Data is Wet Coil

| Airflow (SCFM) | ESP | Airflow (cfm) at External Static Pressure (in. wg) | | | | | | | | | | | | | | | |
|----------------|------------|--|------|------|------|------|------|------|------|------|------|------|------|------|------|------|------|
| | | 0.00 | 0.10 | 0.20 | 0.30 | 0.40 | 0.50 | 0.60 | 0.70 | 0.80 | 0.90 | 1.00 | 1.10 | 1.20 | 1.30 | 1.40 | 1.50 |
| 4600 | BHP | 1.59 | 1.64 | 1.74 | 1.84 | 1.94 | 2.04 | 2.14 | 2.24 | 2.34 | 2.39 | 2.44 | 2.54 | 2.64 | 2.74 | 2.84 | 2.94 |
| | Sheave/Mtr | A | A | A | A | A | D | D | E | E | E | E | E | E | E | E | E |
| | RPM | 668 | 694 | 721 | 745 | 768 | 791 | 816 | 838 | 860 | 883 | 904 | 925 | 945 | 967 | 987 | 1007 |
| | Turns Open | 4.5 | 4 | 3 | 2.5 | 2 | 1.5 | 1 | 6 | 5.5 | 5 | 4.5 | 4 | 3.5 | 3 | 2.5 | 2 |
| 4700 | BHP | 1.74 | 1.84 | 1.89 | 1.94 | 2.04 | 2.14 | 2.24 | 2.34 | 2.44 | 2.54 | 2.64 | 2.69 | 2.74 | 2.84 | 2.94 | |
| | Sheave/Mtr | A | A | A | A | D | D | E | E | E | E | E | E | E | E | E | |
| | RPM | 683 | 711 | 735 | 758 | 782 | 806 | 828 | 850 | 871 | 894 | 915 | 935 | 955 | 977 | 997 | |
| | Turns Open | 4 | 3.5 | 2.5 | 2 | 2 | 1 | 6 | 6 | 5.5 | 5 | 4.5 | 3.5 | 3.5 | 3 | 2 | |
| 4800 | BHP | 1.84 | 1.94 | 1.99 | 2.04 | 2.14 | 2.24 | 2.34 | 2.44 | 2.54 | 2.64 | 2.74 | 2.84 | 2.94 | | | |
| | Sheave/Mtr | A | A | A | D | D | D | E | E | E | E | E | E | E | | | |
| | RPM | 698 | 725 | 749 | 772 | 795 | 819 | 836 | 862 | 883 | 906 | 926 | 946 | 968 | | | |
| | Turns Open | 3.5 | 3 | 2.5 | 2 | 1.5 | 1 | 6 | 5.5 | 5 | 4.5 | 4 | 3.5 | 3 | | | |
| 4900 | BHP | 1.94 | 2.04 | 2.14 | 2.24 | 2.34 | 2.44 | 2.49 | 2.54 | 2.64 | 2.74 | 2.84 | 2.94 | | | | |
| | Sheave/Mtr | A | D | D | D | D | E | E | E | E | E | E | E | | | | |
| | RPM | 715 | 739 | 762 | 785 | 810 | 831 | 853 | 874 | 896 | 917 | 937 | 956 | | | | |
| | Turns Open | 3 | 3 | 2.5 | 2 | 1 | 6 | 5.5 | 5.5 | 5 | 4 | 3.5 | 3 | | | | |
| 5000 | BHP | 2.04 | 2.14 | 2.24 | 2.34 | 2.44 | 2.54 | 2.64 | 2.74 | 2.84 | 2.94 | | | | | | |
| | Sheave/Mtr | D | D | D | D | E | E | E | E | E | E | | | | | | |
| | RPM | 730 | 753 | 776 | 798 | 822 | 844 | 865 | 885 | 908 | 928 | | | | | | |
| | Turns Open | 3 | 2.5 | 2 | 1.5 | 6 | 6 | 5.5 | 5 | 4.5 | 4 | | | | | | |

A = Standard Static/Standard Motor, B = Low Static/Standard Motor, C = High Static/Standard Motor, D = Standard Static/Large Motor, E = High Static/Large Motor
 Unit factory shipped with standard static sheave and drive at 2.5 turns open. Other speed require field selection.

For applications requiring higher static pressures, contact your local representative. Performance data does not include drive losses and is based on sea level conditions. Do not operate in black regions. All airflow in rated at lowest Voltage if unit is dual Voltage rated, i.e. 208V for 208-230V units.

Blower Performance, Cont'd.

HKV 150 Blower Performance

All Data is Wet Coil

| Airflow (SCFM) | ESP | Airflow (cfm) at External Static Pressure (in. wg) | | | | | | | | | | | | | | | |
|----------------|------------|--|------|------|------|------|------|------|------|------|------|------|------|------|------|------|------|
| | | 0.00 | 0.10 | 0.20 | 0.30 | 0.40 | 0.50 | 0.60 | 0.70 | 0.80 | 0.90 | 1.00 | 1.10 | 1.20 | 1.30 | 1.40 | 1.50 |
| 3800 | BHP | | | | | | 1.04 | 1.14 | 1.24 | 1.29 | 1.34 | 1.44 | 1.54 | 1.64 | 1.74 | 1.84 | 1.94 |
| | Sheave/Mtr | | | | | | B | B | B | A | A | A | A | A | A | A | A |
| | RPM | | | | | | 659 | 688 | 718 | 746 | 774 | 802 | 829 | 855 | 879 | 905 | 931 |
| | Turns Open | | | | | | 5.5 | 4.5 | 3.5 | 6 | 5 | 4.5 | 4 | 3 | 2.5 | 2 | 1 |
| 3900 | BHP | | | | | 1.04 | 1.14 | 1.19 | 1.24 | 1.34 | 1.44 | 1.54 | 1.64 | 1.74 | 1.84 | 1.94 | 2.03 |
| | Sheave/Mtr | | | | | B | B | B | B | A | A | A | A | A | A | A | A |
| | RPM | | | | | 639 | 669 | 702 | 729 | 757 | 785 | 811 | 838 | 862 | 887 | 913 | 938 |
| | Turns Open | | | | | 6 | 5 | 4 | 3 | 5.5 | 5 | 4 | 3.5 | 3 | 2 | 1.5 | 1 |
| 4000 | BHP | | | | | 1.14 | 1.19 | 1.24 | 1.34 | 1.44 | 1.54 | 1.64 | 1.69 | 1.74 | 1.84 | 1.94 | 2.04 |
| | Sheave/Mtr | | | | | B | B | B | A | A | A | A | A | A | A | A | C |
| | RPM | | | | | 651 | 683 | 710 | 739 | 767 | 794 | 821 | 845 | 870 | 895 | 920 | 945 |
| | Turns Open | | | | | 5.5 | 4.5 | 4 | 6 | 5.5 | 4.5 | 4 | 3.5 | 2.5 | 2 | 1.5 | 6 |
| 4100 | BHP | | | 1.09 | 1.14 | 1.24 | 1.34 | 1.44 | 1.54 | 1.64 | 1.69 | 1.74 | 1.84 | 1.94 | 2.04 | 2.14 | |
| | Sheave/Mtr | | | B | B | B | B | A | A | A | A | A | A | A | A | C | |
| | RPM | | | 631 | 661 | 692 | 722 | 750 | 778 | 804 | 831 | 854 | 879 | 904 | 928 | 951 | |
| | Turns Open | | | 6 | 5.5 | 4.5 | 3.5 | 5.5 | 5 | 4.5 | 3.5 | 3 | 2.5 | 1.5 | 1 | 6 | |
| 4200 | BHP | | | 1.14 | 1.24 | 1.34 | 1.44 | 1.54 | 1.59 | 1.64 | 1.74 | 1.84 | 1.94 | 2.04 | 2.14 | 2.24 | |
| | Sheave/Mtr | | | B | B | B | B | A | A | A | A | A | A | A | A | C | |
| | RPM | | | 640 | 673 | 703 | 733 | 761 | 788 | 812 | 838 | 863 | 888 | 912 | 934 | 958 | |
| | Turns Open | | | 6 | 5 | 4 | 3 | 5.5 | 4.5 | 4 | 3.5 | 3 | 2 | 1.5 | 1 | 5.5 | |
| 4300 | BHP | | 1.24 | 1.34 | 1.44 | 1.54 | 1.59 | 1.64 | 1.74 | 1.84 | 1.94 | 2.04 | 2.14 | 2.24 | 2.34 | | |
| | Sheave/Mtr | | B | B | B | A | A | A | A | A | A | A | A | A | C | C | |
| | RPM | | 653 | 685 | 715 | 744 | 771 | 796 | 822 | 847 | 872 | 896 | 919 | 942 | 966 | | |
| | Turns Open | | 5.5 | 4.5 | 3.5 | 6 | 5 | 4.5 | 4 | 3 | 2.5 | 2 | 1 | 6 | 5.5 | | |
| 4400 | BHP | | 1.24 | 1.34 | 1.44 | 1.54 | 1.59 | 1.64 | 1.74 | 1.84 | 1.94 | 2.04 | 2.14 | 2.24 | 2.34 | 2.44 | |
| | Sheave/Mtr | | B | B | B | A | A | A | A | A | A | A | A | A | C | C | |
| | RPM | | 633 | 666 | 697 | 726 | 755 | 782 | 806 | 832 | 857 | 881 | 904 | 927 | 950 | 973 | |
| | Turns Open | | 6 | 5 | 4 | 3 | 5.5 | 5 | 4 | 3.5 | 3 | 2.5 | 1.5 | 1 | 6 | 5.5 | |
| 4500 | BHP | | 1.3 | 1.4 | 1.5 | 1.6 | 1.7 | 1.8 | 1.9 | 2 | 2.1 | 2.2 | 2.3 | 2.4 | 2.5 | 2.6 | |
| | Sheave/Mtr | | B | B | B | A | A | A | A | A | A | A | A | C | C | C | |
| | RPM | | 646 | 678 | 706 | 735 | 763 | 791 | 817 | 842 | 867 | 889 | 912 | 935 | 958 | 980 | |
| | Turns Open | | 5.5 | 4.5 | 4 | 6 | 5.5 | 4.5 | 4 | 3.5 | 2.5 | 2 | 1.5 | 6 | 6 | 5 | |
| 4600 | BHP | | 1.34 | 1.44 | 1.54 | 1.64 | 1.74 | 1.84 | 1.94 | 2.04 | 2.14 | 2.24 | 2.34 | 2.44 | 2.54 | 2.64 | |
| | Sheave/Mtr | | B | B | B | A | A | A | A | A | A | A | A | C | C | C | |
| | RPM | | 656 | 687 | 715 | 744 | 772 | 799 | 825 | 850 | 872 | 896 | 919 | 942 | 963 | 987 | |
| | Turns Open | | 5.5 | 4.5 | 3.5 | 6 | 5 | 4.5 | 3.5 | 3 | 2.5 | 2 | 1 | 6 | 5.5 | 5 | |
| 4700 | BHP | | 1.34 | 1.44 | 1.54 | 1.64 | 1.74 | 1.84 | 1.94 | 2.04 | 2.14 | 2.24 | 2.34 | 2.44 | 2.54 | 2.64 | 2.74 |
| | Sheave/Mtr | | B | B | B | B | A | A | A | A | A | A | A | C | C | C | |
| | RPM | | 637 | 666 | 697 | 727 | 755 | 783 | 809 | 835 | 858 | 882 | 905 | 928 | 951 | 973 | 994 |
| | Turns Open | | 6 | 5 | 4 | 3 | 5.5 | 5 | 4 | 3.5 | 3 | 2 | 1.5 | 1 | 6 | 5.5 | 4.5 |
| 4800 | BHP | | 1.44 | 1.54 | 1.64 | 1.74 | 1.84 | 1.94 | 2.04 | 2.14 | 2.24 | 2.34 | 2.44 | 2.54 | 2.64 | 2.74 | 2.84 |
| | Sheave/Mtr | | B | B | B | A | A | A | A | A | A | A | C | C | C | C | |
| | RPM | | 647 | 678 | 708 | 738 | 766 | 793 | 819 | 844 | 867 | 891 | 914 | 937 | 959 | 980 | 1001 |
| | Turns Open | | 5.5 | 4.5 | 3.5 | 6 | 5 | 4.5 | 4 | 3.5 | 2.5 | 2 | 1.5 | 6 | 5.5 | 5 | 4.5 |
| 4900 | BHP | 1.44 | 1.54 | 1.64 | 1.74 | 1.84 | 1.94 | 2.04 | 2.14 | 2.24 | 2.34 | 2.44 | 2.54 | 2.64 | 2.74 | 2.84 | 2.94 |
| | Sheave/Mtr | B | B | B | B | A | A | A | A | A | A | A | C | C | C | C | |
| | RPM | 631 | 662 | 690 | 720 | 749 | 777 | 803 | 827 | 852 | 877 | 900 | 923 | 946 | 966 | 988 | 1009 |
| | Turns Open | 6 | 5 | 4 | 3.5 | 5.5 | 5 | 4.5 | 3.5 | 3 | 2.5 | 2 | 1 | 6 | 5.5 | 5 | 4.5 |
| 5000 | BHP | 1.54 | 1.64 | 1.74 | 1.84 | 1.94 | 2.04 | 2.14 | 2.24 | 2.34 | 2.44 | 2.54 | 2.64 | 2.74 | 2.84 | 2.94 | 3.04 |
| | Sheave/Mtr | B | B | B | B | A | A | A | A | A | A | A | C | C | C | E | |
| | RPM | 642 | 672 | 702 | 731 | 760 | 785 | 811 | 837 | 862 | 886 | 909 | 932 | 953 | 975 | 996 | 1017 |
| | Turns Open | 5.5 | 5 | 3.5 | 3 | 5.5 | 4.5 | 4 | 3.5 | 3 | 2 | 1.5 | 1 | 6 | 5 | 4.5 | 4.5 |
| 5100 | BHP | 1.64 | 1.74 | 1.84 | 1.94 | 2.04 | 2.14 | 2.24 | 2.34 | 2.44 | 2.54 | 2.64 | 2.74 | 2.84 | 2.94 | 3.04 | 3.19 |
| | Sheave/Mtr | B | B | B | A | A | A | A | A | A | A | C | C | C | E | E | |
| | RPM | 655 | 685 | 714 | 743 | 769 | 798 | 822 | 847 | 872 | 896 | 917 | 940 | 962 | 983 | 1005 | 1025 |
| | Turns Open | 5.5 | 4.5 | 3.5 | 6 | 5 | 4.5 | 4 | 3 | 2.5 | 2 | 1.5 | 6 | 5.5 | 5 | 5 | 4.5 |
| 5200 | BHP | 1.74 | 1.84 | 1.94 | 2.04 | 2.14 | 2.24 | 2.34 | 2.44 | 2.54 | 2.64 | 2.74 | 2.84 | 2.94 | 3.09 | 3.19 | 3.29 |
| | Sheave/Mtr | B | B | B | A | A | A | A | A | A | A | C | C | E | E | E | |
| | RPM | 668 | 697 | 726 | 752 | 782 | 806 | 832 | 857 | 882 | 903 | 926 | 949 | 971 | 992 | 1013 | 1032 |
| | Turns Open | 5 | 4 | 3 | 5.5 | 5 | 4 | 3.5 | 3 | 2 | 1.5 | 1 | 6 | 5.5 | 5 | 4.5 | 4 |
| 5300 | BHP | 1.84 | 1.94 | 2.04 | 2.14 | 2.24 | 2.34 | 2.44 | 2.54 | 2.64 | 2.74 | 2.84 | 2.94 | 3.09 | 3.19 | 3.29 | 3.39 |
| | Sheave/Mtr | B | B | A | A | A | A | A | A | A | C | C | E | E | E | E | |
| | RPM | 680 | 709 | 737 | 763 | 790 | 817 | 842 | 867 | 889 | 912 | 935 | 957 | 979 | 1000 | 1021 | 1042 |
| | Turns Open | 4.5 | 3.5 | 6 | 5.5 | 4.5 | 4 | 3.5 | 2.5 | 2 | 1.5 | 6 | 5.5 | 5 | 4.5 | 4 | 4 |

A = Standard Static/Standard Motor, B = Low Static/Standard Motor, C = High Static/Standard Motor, D = Standard Static/Large Motor, E = High Static/Large Motor
 Unit factory shipped with standard static sheave and drive at 2.5 turns open. Other speed require field selection.
 For applications requiring higher static pressures, contact your local representative. Performance data does not include drive losses and is based on sea level conditions. Do not operate in black regions. All airflow in rated at lowest Voltage if unit is dual Voltage rated, i.e. 208V for 208-230V units.

Table Continued on Next Page

Blower Performance, Cont'd.

Table Continued from Previous Page

All Data is Wet Coil

| Airflow (SCFM) | ESP | Airflow (cfm) at External Static Pressure (in. wg) | | | | | | | | | | | | | | | |
|----------------|------------|--|------|------|------|------|------|------|------|------|------|------|------|------|------|------|------|
| | | 0.00 | 0.10 | 0.20 | 0.30 | 0.40 | 0.50 | 0.60 | 0.70 | 0.80 | 0.90 | 1.00 | 1.10 | 1.20 | 1.30 | 1.40 | 1.50 |
| 5400 | BHP | 1.94 | 2.04 | 2.14 | 2.24 | 2.34 | 2.44 | 2.54 | 2.64 | 2.74 | 2.84 | 2.94 | 3.09 | 3.19 | 3.29 | 3.39 | 3.49 |
| | Sheave/Mtr | B | B | A | A | A | A | A | A | A | A | C | E | E | E | E | E |
| | RPM | 691 | 717 | 745 | 772 | 799 | 825 | 850 | 873 | 897 | 920 | 943 | 965 | 986 | 1006 | 1026 | 1047 |
| | Turns Open | 4 | 3.5 | 5.5 | 5 | 4.5 | 3.5 | 3 | 2.5 | 1.5 | 1 | 6 | 6 | 5 | 4.5 | 4 | 3.5 |
| 5500 | BHP | 2.04 | 2.14 | 2.24 | 2.34 | 2.44 | 2.54 | 2.64 | 2.74 | 2.84 | 3.09 | 3.14 | 3.24 | 3.34 | 3.44 | 3.54 | 3.69 |
| | Sheave/Mtr | B | A | A | A | A | A | A | A | A | D | E | E | E | E | E | E |
| | RPM | 704 | 729 | 756 | 783 | 810 | 836 | 859 | 883 | 907 | 929 | 952 | 972 | 993 | 1014 | 1035 | 1055 |
| | Turns Open | 4 | 6 | 5.5 | 4.5 | 4 | 3.5 | 3 | 2 | 1.5 | 1 | 6 | 5.5 | 5 | 4.5 | 4 | 3.5 |
| 5600 | BHP | 2.14 | 2.24 | 2.34 | 2.44 | 2.54 | 2.64 | 2.74 | 2.84 | 3.00 | 3.14 | 3.24 | 3.34 | 3.44 | 3.54 | 3.69 | 3.79 |
| | Sheave/Mtr | B | A | A | A | A | A | A | A | D | D | E | E | E | E | E | E |
| | RPM | 714 | 740 | 767 | 794 | 818 | 844 | 868 | 892 | 916 | 938 | 959 | 981 | 1002 | 1023 | 1043 | 1063 |
| | Turns Open | 3.5 | 6 | 5 | 4.5 | 4 | 3 | 2.5 | 2 | 1.5 | 1 | 6 | 5.5 | 4.5 | 4 | 3.5 | 3 |
| 5700 | BHP | 2.24 | 2.34 | 2.44 | 2.54 | 2.64 | 2.74 | 2.89 | 3.04 | 3.14 | 3.24 | 3.34 | 3.44 | 3.59 | 3.74 | 3.84 | 3.94 |
| | Sheave/Mtr | B | A | A | A | A | A | A | D | D | E | E | E | E | E | E | E |
| | RPM | 726 | 752 | 779 | 803 | 829 | 854 | 878 | 902 | 925 | 948 | 970 | 990 | 1011 | 1031 | 1051 | 1071 |
| | Turns Open | 3 | 5.5 | 5 | 4 | 3.5 | 3 | 2 | 2 | 1 | 6 | 5.5 | 5 | 4.5 | 4 | 3.5 | 3 |
| 5800 | BHP | 2.34 | 2.44 | 2.54 | 2.64 | 2.74 | 2.84 | 3.00 | 3.14 | 3.24 | 3.34 | 3.44 | 3.59 | 3.74 | 3.84 | 3.94 | 4.04 |
| | Sheave/Mtr | A | A | A | A | A | A | D | D | D | E | E | E | E | E | E | E |
| | RPM | 738 | 763 | 788 | 813 | 839 | 864 | 888 | 911 | 934 | 955 | 977 | 998 | 1019 | 1039 | 1058 | 1077 |
| | Turns Open | 6 | 5 | 4.5 | 4 | 3.5 | 2.5 | 2 | 1.5 | 1 | 6 | 5.5 | 5 | 4.5 | 4 | 3.5 | 2.5 |
| 5900 | BHP | 2.44 | 2.54 | 2.64 | 2.74 | 2.89 | 3.04 | 3.14 | 3.24 | 3.34 | 3.49 | 3.64 | 3.74 | 3.84 | 3.94 | 4.09 | 4.19 |
| | Sheave/Mtr | A | A | A | A | A | D | D | D | E | E | E | E | E | E | E | E |
| | RPM | 750 | 775 | 799 | 824 | 849 | 874 | 898 | 921 | 944 | 964 | 986 | 1007 | 1027 | 1046 | 1068 | 1086 |
| | Turns Open | 5.5 | 5 | 4 | 3.5 | 3 | 2.5 | 2 | 1.5 | 6 | 5.5 | 5 | 4.5 | 4 | 3.5 | 3 | 2.5 |
| 6000 | BHP | 2.54 | 2.64 | 2.74 | 2.89 | 3.04 | 3.14 | 3.24 | 3.34 | 3.49 | 3.64 | 3.74 | 3.84 | 3.99 | 4.14 | 4.24 | 4.34 |
| | Sheave/Mtr | A | A | A | A | D | D | D | D | E | E | E | E | E | E | E | E |
| | RPM | 758 | 783 | 808 | 833 | 858 | 880 | 904 | 927 | 950 | 972 | 993 | 1014 | 1033 | 1053 | 1073 | 1092 |
| | Turns Open | 5.5 | 4.5 | 4 | 3.5 | 3 | 2.5 | 1.5 | 1 | 6 | 5.5 | 5 | 4.5 | 4 | 3.5 | 3 | 2.5 |
| 6100 | BHP | 2.64 | 2.74 | 2.89 | 3.04 | 3.14 | 3.24 | 3.34 | 3.49 | 3.64 | 3.74 | 3.84 | 3.99 | 4.14 | 1.24 | 4.34 | 4.49 |
| | Sheave/Mtr | A | A | A | D | D | D | D | D | E | E | E | E | E | E | E | E |
| | RPM | 769 | 794 | 819 | 843 | 866 | 890 | 913 | 936 | 958 | 980 | 1000 | 1021 | 1041 | 1061 | 1081 | 1099 |
| | Turns Open | 5 | 4.5 | 3.5 | 3.5 | 2.5 | 2 | 1.5 | 1 | 6 | 5.5 | 4.5 | 4 | 3.5 | 3 | 2.5 | 2 |
| 6200 | BHP | 2.84 | 2.94 | 3.04 | 3.14 | 3.24 | 3.39 | 3.54 | 3.64 | 3.74 | 3.89 | 4.04 | 4.14 | 4.24 | 4.39 | 4.54 | 4.64 |
| | Sheave/Mtr | A | A | D | D | D | D | D | E | E | E | E | E | E | E | E | E |
| | RPM | 781 | 815 | 830 | 854 | 878 | 900 | 923 | 946 | 968 | 988 | 1009 | 1030 | 1050 | 1070 | 1089 | 1107 |
| | Turns Open | 4.5 | 4 | 3.5 | 3 | 2.5 | 2 | 1 | 6 | 5.5 | 5 | 4.5 | 4 | 3.5 | 3 | 2.5 | 2 |
| 6300 | BHP | 2.94 | 3.04 | 3.14 | 3.29 | 3.44 | 3.54 | 3.64 | 3.79 | 3.94 | 4.04 | 4.14 | 4.29 | 4.44 | 4.54 | 4.69 | 4.84 |
| | Sheave/Mtr | A | D | D | D | D | D | D | E | E | E | E | E | E | E | E | E |
| | RPM | 793 | 817 | 841 | 863 | 886 | 910 | 933 | 955 | 977 | 997 | 1018 | 1038 | 1058 | 1078 | 1097 | 1115 |
| | Turns Open | 4.5 | 4 | 3.5 | 3 | 2 | 1.5 | | 6 | 5.5 | 5 | 4.5 | 4 | 3 | 2.5 | 2 | 1.5 |

A = Standard Static/Standard Motor, B = Low Static/Standard Motor, C = High Static/Standard Motor, D = Standard Static/Large Motor, E = High Static/Large Motor
 Unit factory shipped with standard static sheave and drive at 2.5 turns open. Other speed require field selection.
 For applications requiring higher static pressures, contact your local representative. Performance data does not include drive losses and is based on sea level conditions.
 Do not operate in black regions. All airflow in rated at lowest Voltage if unit is dual Voltage rated, i.e. 208V for 208-230V units.

Blower Performance, Cont'd.

HKV 168 Blower Performance

All Data is Wet Coil

| Airflow (SCFM) | ESP | Airflow (cfm) at External Static Pressure (in. wg) | | | | | | | | | | | | | | | | | | |
|----------------|------------|--|------|------|------|------|------|------|------|------|------|------|------|------|------|------|------|-----|-----|-----|
| | | 0.00 | 0.10 | 0.20 | 0.30 | 0.40 | 0.50 | 0.60 | 0.70 | 0.80 | 0.90 | 1.00 | 1.10 | 1.20 | 1.30 | 1.40 | 1.50 | | | |
| 4200 | BHP | | | | 0.58 | 0.68 | 0.74 | 0.82 | 0.88 | 0.98 | 1.08 | 1.18 | 1.28 | 1.38 | 1.48 | 1.58 | 1.68 | | | |
| | Sheave/Mtr | | | | B | B | B | B | A | A | A | A | A | A | A | A | C | | | |
| | RPM | | | | 457 | 499 | 537 | 577 | 612 | 647 | 678 | 710 | 737 | 764 | 791 | 815 | 838 | | | |
| | Turns Open | | | | 6 | 5 | 3.5 | 2.5 | 6 | 5.5 | 4.5 | 3.5 | 3 | 2 | 1.5 | 1 | 3 | | | |
| 4400 | BHP | | | | 0.63 | 0.68 | 0.78 | 0.88 | 0.98 | 1.08 | 1.18 | 1.28 | 1.38 | 1.48 | 1.58 | 1.68 | 1.8 | | | |
| | Sheave/Mtr | | | | B | B | B | B | A | A | A | A | A | A | A | C | C | | | |
| | RPM | | | | 467 | 507 | 548 | 584 | 621 | 653 | 684 | 716 | 743 | 772 | 797 | 821 | 847 | | | |
| | Turns Open | | | | 5.5 | 4.5 | 3.5 | 2.5 | 6 | 5 | 4 | 3.5 | 2.5 | 2 | 1 | 3.5 | 3 | | | |
| 4600 | BHP | | | | 0.68 | 0.78 | 0.88 | 0.98 | 1.08 | 1.18 | 1.28 | 1.38 | 1.48 | 1.58 | 1.68 | 1.78 | 1.88 | | | |
| | Sheave/Mtr | | | | B | B | B | B | A | A | A | A | A | A | A | C | C | | | |
| | RPM | | | | 476 | 518 | 555 | 590 | 627 | 659 | 692 | 721 | 751 | 777 | 803 | 829 | 853 | | | |
| | Turns Open | | | | 5.5 | 4.5 | 3 | 2 | 5.5 | 5 | 4 | 3 | 2.5 | 1.5 | 1 | 3.5 | 2.5 | | | |
| 4800 | BHP | | | 0.68 | 0.78 | 0.88 | 0.98 | 1.08 | 1.18 | 1.28 | 1.38 | 1.48 | 1.58 | 1.68 | 1.78 | 1.88 | 1.98 | | | |
| | Sheave/Mtr | | | | B | B | B | B | A | A | A | A | A | A | C | C | C | | | |
| | RPM | | | | 446 | 485 | 527 | 563 | 600 | 633 | 665 | 697 | 726 | 756 | 783 | 811 | 835 | 858 | | |
| | Turns Open | | | | 6 | 5 | 4 | 3 | 1.5 | 5.5 | 4.5 | 4 | 3 | 2.5 | 1.5 | 4 | 3 | 2.5 | | |
| 5000 | BHP | | | 0.68 | 0.78 | 0.88 | 0.98 | 1.08 | 1.18 | 1.28 | 1.48 | 1.58 | 1.68 | 1.78 | 1.88 | 1.98 | 2.08 | | | |
| | Sheave/Mtr | | | | B | B | B | B | A | A | A | A | A | A | C | C | E | | | |
| | RPM | | | | 452 | 495 | 532 | 567 | 604 | 636 | 670 | 709 | 759 | 786 | 813 | 838 | 864 | | | |
| | Turns Open | | | | 6 | 5 | 4 | 2.5 | 1.5 | 5.5 | 4.5 | 3.5 | 3 | 2 | 1.5 | 4 | 3 | 2.5 | | |
| 5200 | BHP | | | 0.86 | 0.96 | 1.06 | 1.16 | 1.26 | 1.36 | 1.46 | 1.56 | 1.66 | 1.76 | 1.86 | 2.06 | 2.16 | 2.26 | | | |
| | Sheave/Mtr | | | | B | B | B | B | A | A | A | A | A | A | E | E | E | | | |
| | RPM | | | | 460 | 500 | 536 | 570 | 606 | 638 | 671 | 701 | 729 | 759 | 786 | 814 | 839 | 865 | | |
| | Turns Open | | | | 6 | 4.5 | 3.5 | 2.5 | 6 | 5.5 | 4.5 | 3.5 | 2.5 | 2 | 1 | 4 | 3.5 | 2.5 | | |
| 5400 | BHP | | | 0.86 | 0.96 | 1.06 | 1.18 | 1.28 | 1.38 | 1.48 | 1.58 | 1.68 | 1.78 | 1.88 | 2.08 | 2.18 | 2.28 | | | |
| | Sheave/Mtr | | | | B | B | B | B | A | A | A | A | A | A | E | E | E | | | |
| | RPM | | | | 463 | 504 | 539 | 576 | 609 | 641 | 674 | 703 | 734 | 762 | 788 | 816 | 841 | 867 | | |
| | Turns Open | | | | 5.5 | 4.5 | 3.5 | 2.5 | 6 | 5 | 4.5 | 3.5 | 2.5 | 2 | 1 | 4 | 3.5 | 2.5 | | |
| 5600 | BHP | | | 0.88 | 0.98 | 1.08 | 1.28 | 1.38 | 1.48 | 1.58 | 1.68 | 1.78 | 1.88 | 2.08 | 2.18 | 2.24 | 2.44 | | | |
| | Sheave/Mtr | | | | B | B | B | B | A | A | A | A | A | D | E | E | E | | | |
| | RPM | | | | 474 | 510 | 545 | 581 | 613 | 647 | 677 | 706 | 737 | 764 | 793 | 818 | 843 | 869 | | |
| | Turns Open | | | | 5.5 | 4 | 3 | 2 | 6 | 5 | 4 | 3 | 2.5 | 1.5 | 4 | 3.5 | 2.5 | | | |
| 5800 | BHP | | 0.88 | 0.98 | 1.08 | 1.18 | 1.28 | 1.48 | 1.58 | 1.68 | 1.78 | 1.88 | 2.08 | 2.18 | 2.28 | 2.38 | 2.48 | | | |
| | Sheave/Mtr | | | | B | B | B | B | A | A | A | A | D | D | E | E | E | | | |
| | RPM | | | | 440 | 481 | 517 | 551 | 586 | 618 | 651 | 681 | 710 | 740 | 767 | 795 | 821 | 845 | 872 | |
| | Turns Open | | | | 6 | 5 | 4 | 3 | 2 | 5.5 | 4.5 | 4 | 3 | 2 | 2 | 1.5 | 3.5 | 3 | 2 | |
| 6000 | BHP | | 0.98 | 1.08 | 1.18 | 1.28 | 1.38 | 1.48 | 1.68 | 1.78 | 1.88 | 2.08 | 2.18 | 2.28 | 2.38 | 2.48 | 2.58 | | | |
| | Sheave/Mtr | | | | B | B | B | B | A | A | A | A | D | D | E | E | E | | | |
| | RPM | | | | 455 | 492 | 526 | 563 | 595 | 628 | 658 | 687 | 718 | 745 | 774 | 800 | 826 | 852 | 876 | |
| | Turns Open | | | | 6 | 5 | 3.5 | 2.5 | 1.5 | 5.5 | 4.5 | 3.5 | 3 | 2.5 | 2 | 1.5 | 3.5 | 3 | 2 | |
| 6200 | BHP | | 1.06 | 1.18 | 1.28 | 1.38 | 1.48 | 1.68 | 1.78 | 1.88 | 1.98 | 2.08 | 2.28 | 2.38 | 2.48 | 2.68 | 2.78 | | | |
| | Sheave/Mtr | | | | B | B | B | B | A | A | A | A | D | D | E | E | E | | | |
| | RPM | | | | 459 | 499 | 533 | 569 | 600 | 633 | 663 | 691 | 722 | 749 | 777 | 803 | 828 | 854 | 878 | |
| | Turns Open | | | | 5.5 | 4.5 | 3.5 | 2.5 | 1.5 | 5.5 | 4 | 3.5 | 2.5 | 2 | 1 | 3.5 | 3 | 2 | | |
| 6400 | BHP | 0.98 | 1.08 | 1.28 | 1.38 | 1.48 | 1.68 | 1.78 | 1.88 | 1.98 | 2.08 | 2.28 | 2.38 | 2.48 | 2.68 | 2.78 | 2.88 | | | |
| | Sheave/Mtr | | | | B | B | B | B | A | A | A | D | D | D | E | E | E | | | |
| | RPM | | | | 441 | 478 | 513 | 549 | 581 | 614 | 644 | 672 | 703 | 730 | 759 | 785 | 810 | 837 | 861 | 887 |
| | Turns Open | | | | 6 | 5.5 | 4 | 3 | 2 | 6 | 5 | 4 | 3.5 | 3 | 2.5 | 1.5 | 3 | 2.5 | 2 | |
| 6600 | BHP | 1.08 | 1.28 | 1.38 | 1.48 | 1.66 | 1.78 | 1.88 | 1.98 | 2.08 | 2.28 | 2.46 | 2.58 | 2.68 | 2.88 | 2.98 | | | | |
| | Sheave/Mtr | | | | B | B | B | B | A | A | A | D | D | D | E | E | E | | | |
| | RPM | | | | 456 | 495 | 529 | 561 | 595 | 625 | 656 | 685 | 712 | 741 | 767 | 795 | 820 | 844 | 870 | |
| | Turns Open | | | | 6 | 5 | 3.5 | 2.5 | 2 | 5.5 | 4.5 | 4 | 3.5 | 3 | 2 | 1.5 | 3.5 | 3 | 2.5 | |
| 6800 | BHP | 1.26 | 1.38 | 1.48 | 1.58 | 1.68 | 1.88 | 1.98 | 2.08 | 2.28 | 2.38 | 2.48 | 2.68 | 2.88 | 2.98 | | | | | |
| | Sheave/Mtr | | | | B | B | B | B | A | A | D | D | D | D | E | E | | | | |
| | RPM | | | | 471 | 506 | 539 | 574 | 604 | 633 | 664 | 692 | 721 | 747 | 773 | 800 | 825 | 851 | | |
| | Turns Open | | | | 5.5 | 4.5 | 3.5 | 2.5 | 6 | 5.5 | 4.5 | 4 | 3 | 2.5 | 2 | 1 | 3.5 | 2.5 | | |
| 7000 | BHP | 1.28 | 1.48 | 1.58 | 1.68 | 1.88 | 1.98 | 2.08 | 2.28 | 2.46 | 2.58 | 2.68 | 2.88 | 2.98 | | | | | | |
| | Sheave/Mtr | | | | B | B | B | B | A | A | D | D | D | D | E | | | | | |
| | RPM | | | | 486 | 520 | 555 | 586 | 615 | 647 | 674 | 704 | 730 | 756 | 784 | 808 | 835 | | | |
| | Turns Open | | | | 5 | 4 | 3 | 2 | 6 | 5 | 4.5 | 3.5 | 3 | 2.5 | 1.5 | 1 | 3 | | | |

A = Standard Static/Standard Motor, B = Low Static/Standard Motor, C = High Static/Standard Motor, D = Standard Static/Large Motor, E = High Static/Large Motor
 Unit factory shipped with standard static sheave and drive at 2.5 turns open. Other speed require field selection.
 For applications requiring higher static pressures, contact your local representative. Performance data does not include drive losses and is based on sea level conditions.
 Do not operate in black regions. All airflow in rated at lowest Voltage if unit is dual Voltage rated, i.e. 208V for 208-230V units.

Blower Performance, Cont'd.

HKV 192 Blower Performance

All Data is Wet Coil

| Airflow (SCFM) | ESP | Airflow (cfm) at External Static Pressure (in. wg) | | | | | | | | | | | | | | | | | |
|----------------|------------|--|------|------|------|------|------|------|------|------|------|------|------|------|------|------|------|-----|-----|
| | | 0.00 | 0.10 | 0.20 | 0.30 | 0.40 | 0.50 | 0.60 | 0.70 | 0.80 | 0.90 | 1.00 | 1.10 | 1.20 | 1.30 | 1.40 | 1.50 | | |
| 4800 | BHP | | | 0.68 | 0.78 | 0.88 | 0.98 | 1.08 | 1.18 | 1.28 | 1.38 | 1.48 | 1.58 | 1.68 | 1.78 | 1.88 | 1.98 | | |
| | Sheave/Mtr | | | B | B | B | B | B | A | A | A | A | A | A | C | C | C | | |
| | RPM | | | 446 | 485 | 527 | 563 | 600 | 633 | 665 | 697 | 726 | 756 | 783 | 811 | 835 | 858 | | |
| | Turns Open | | | 6 | 5 | 4 | 3 | 1.5 | 5.5 | 4.5 | 4 | 3 | 2.5 | 1.5 | 3.5 | 3 | 2.5 | | |
| 5000 | BHP | | | 0.68 | 0.78 | 0.88 | 0.98 | 1.08 | 1.18 | 1.28 | 1.48 | 1.58 | 1.68 | 1.78 | 1.88 | 1.98 | 2.08 | | |
| | Sheave/Mtr | | | B | B | B | B | B | A | A | A | A | A | A | C | C | C | | |
| | RPM | | | 452 | 495 | 532 | 567 | 604 | 636 | 670 | 700 | 729 | 759 | 786 | 813 | 838 | 864 | | |
| | Turns Open | | | 6 | 5 | 4 | 2.5 | 1.5 | 5.5 | 4.5 | 3.5 | 3 | 2.5 | 1.5 | 3.5 | 3 | 2.5 | | |
| 5200 | BHP | | | 0.86 | 0.96 | 1.06 | 1.16 | 1.26 | 1.36 | 1.46 | 1.56 | 1.66 | 1.76 | 1.86 | 2.06 | 2.16 | 2.26 | | |
| | Sheave/Mtr | | | B | B | B | B | B | A | A | A | A | A | A | C | C | C | | |
| | RPM | | | 460 | 500 | 536 | 570 | 606 | 638 | 671 | 701 | 729 | 759 | 786 | 814 | 839 | 865 | | |
| | Turns Open | | | 6 | 5 | 3.5 | 2.5 | 1.5 | 5 | 4.5 | 3.5 | 3 | 2.5 | 1 | 4 | 3 | 2.5 | | |
| 5400 | BHP | | | 0.86 | 0.96 | 1.06 | 1.18 | 1.28 | 1.38 | 1.48 | 1.58 | 1.68 | 1.78 | 1.88 | 2.08 | 2.18 | 2.28 | | |
| | Sheave/Mtr | | | B | B | B | B | A | A | A | A | A | A | A | C | C | C | | |
| | RPM | | | 463 | 504 | 539 | 576 | 609 | 641 | 674 | 703 | 734 | 762 | 788 | 816 | 841 | 867 | | |
| | Turns Open | | | 5.5 | 4.5 | 3.5 | 2.5 | 6 | 5 | 4 | 3.5 | 2.5 | 2 | 1 | 4 | 3 | 2.5 | | |
| 5600 | BHP | | | 0.88 | 0.98 | 1.08 | 1.28 | 1.38 | 1.48 | 1.58 | 1.68 | 1.78 | 1.88 | 2.08 | 2.18 | 2.24 | 2.44 | | |
| | Sheave/Mtr | | | B | B | B | B | A | A | A | A | A | A | A | C | C | C | | |
| | RPM | | | 474 | 510 | 545 | 581 | 613 | 647 | 677 | 706 | 737 | 764 | 793 | 818 | 843 | 869 | | |
| | Turns Open | | | 5.5 | 4.5 | 3 | 2 | 6 | 5 | 4 | 3.5 | 2.5 | 2 | 1.5 | 4 | 3 | 2.5 | | |
| 5800 | BHP | | 0.88 | 0.98 | 1.08 | 1.18 | 1.28 | 1.48 | 1.58 | 1.68 | 1.78 | 1.88 | 2.08 | 2.18 | 2.28 | 2.38 | 2.48 | | |
| | Sheave/Mtr | | | B | B | B | B | A | A | A | A | A | A | A | C | C | C | | |
| | RPM | | | 440 | 481 | 517 | 551 | 586 | 618 | 651 | 681 | 710 | 740 | 767 | 795 | 821 | 845 | 872 | |
| | Turns Open | | | 6 | 5 | 4 | 3 | 2 | 6 | 4.5 | 4 | 3 | 2.5 | 2 | 1.5 | 3.5 | 3 | 2.5 | |
| 6000 | BHP | | 0.98 | 1.08 | 1.18 | 1.28 | 1.38 | 1.48 | 1.68 | 1.78 | 1.88 | 2.08 | 2.18 | 2.28 | 2.38 | 2.48 | 2.58 | | |
| | Sheave/Mtr | | | B | B | B | B | A | A | A | A | A | A | A | C | C | C | | |
| | RPM | | | 455 | 492 | 526 | 563 | 595 | 628 | 658 | 687 | 718 | 745 | 774 | 800 | 826 | 852 | 876 | |
| | Turns Open | | | 6 | 5 | 4 | 2.5 | 1.5 | 5.5 | 4.5 | 3.5 | 3 | 2.5 | 2 | 1.5 | 3.5 | 3 | 2 | |
| 6200 | BHP | | 1.06 | 1.18 | 1.28 | 1.38 | 1.48 | 1.68 | 1.78 | 1.88 | 1.98 | 2.08 | 2.28 | 2.38 | 2.48 | 2.68 | 2.78 | | |
| | Sheave/Mtr | | | B | B | B | B | A | A | A | A | A | A | A | C | C | C | | |
| | RPM | | | 459 | 499 | 533 | 569 | 600 | 633 | 663 | 691 | 722 | 749 | 777 | 803 | 828 | 854 | 878 | |
| | Turns Open | | | 6 | 4.5 | 3.5 | 2.5 | 1.5 | 5.5 | 4.5 | 3.5 | 3 | 2 | 1.5 | 1 | 3.5 | 3 | 2 | |
| 6400 | BHP | 0.98 | 1.08 | 1.28 | 1.38 | 1.48 | 1.68 | 1.78 | 1.88 | 1.98 | 2.08 | 2.28 | 2.38 | 2.48 | 2.68 | 2.78 | 2.88 | | |
| | Sheave/Mtr | | | B | B | B | B | A | A | A | A | A | A | A | C | C | C | | |
| | RPM | | | 441 | 478 | 513 | 549 | 581 | 614 | 644 | 672 | 703 | 730 | 759 | 785 | 810 | 837 | 861 | 887 |
| | Turns Open | | | 6 | 5 | 4.5 | 3 | 2 | 6 | 5 | 4 | 3.5 | 2.5 | 2 | 1.5 | 1 | 3.5 | 2.5 | 2 |
| 6600 | BHP | 1.08 | 1.28 | 1.38 | 1.48 | 1.66 | 1.78 | 1.88 | 1.98 | 2.08 | 2.28 | 2.46 | 2.58 | 2.68 | 2.88 | 2.98 | 3.08 | | |
| | Sheave/Mtr | | | B | B | B | B | A | A | A | A | A | A | C | C | C | E | | |
| | RPM | | | 456 | 495 | 529 | 561 | 595 | 625 | 656 | 685 | 712 | 741 | 767 | 795 | 820 | 844 | 870 | 893 |
| | Turns Open | | | 6 | 5 | 4 | 3 | 2 | 6 | 4.5 | 4 | 3.5 | 2.5 | 2 | 1.5 | 3.5 | 3 | 2.5 | 2 |
| 6800 | BHP | 1.26 | 1.38 | 1.48 | 1.58 | 1.68 | 1.88 | 1.98 | 2.08 | 2.28 | 2.38 | 2.48 | 2.68 | 2.88 | 2.98 | 3.08 | 3.28 | | |
| | Sheave/Mtr | | | B | B | B | B | A | A | A | A | A | A | A | C | C | E | E | |
| | RPM | | | 471 | 506 | 539 | 574 | 604 | 633 | 664 | 692 | 721 | 747 | 773 | 800 | 825 | 851 | 875 | 898 |
| | Turns Open | | | 5.5 | 4.5 | 3.5 | 2.5 | 6 | 5.5 | 4.5 | 4 | 3 | 2.5 | 2 | 1.5 | 3.5 | 3 | 2 | 1.5 |
| 7000 | BHP | 1.28 | 1.48 | 1.58 | 1.68 | 1.88 | 1.98 | 2.08 | 2.28 | 2.46 | 2.58 | 2.68 | 2.88 | 2.98 | 3.08 | 3.28 | 3.48 | | |
| | Sheave/Mtr | | | B | B | B | B | A | A | A | A | A | A | C | C | E | E | E | |
| | RPM | | | 486 | 520 | 555 | 586 | 615 | 647 | 674 | 704 | 730 | 756 | 784 | 808 | 835 | 858 | 883 | 906 |
| | Turns Open | | | 5 | 4 | 3 | 2 | 6 | 5 | 4.5 | 3.5 | 3 | 2 | 1.5 | 3.5 | 3 | 2.5 | 2 | 1.5 |
| 7200 | BHP | 1.48 | 1.58 | 1.68 | 1.88 | 1.98 | 2.08 | 2.28 | 2.38 | 2.48 | 2.68 | 2.88 | 2.98 | 3.08 | 3.28 | 3.48 | 3.66 | | |
| | Sheave/Mtr | | | B | B | B | B | A | A | A | A | A | A | C | E | E | E | E | |
| | RPM | | | 495 | 528 | 562 | 593 | 624 | 652 | 680 | 708 | 734 | 762 | 787 | 812 | 838 | 861 | 886 | 909 |
| | Turns Open | | | 4.5 | 4 | 2.5 | 1.5 | 6 | 5 | 4 | 3.5 | 3 | 2 | 1.5 | 4 | 3 | 2.5 | 2 | 1.5 |
| 7400 | BHP | 1.58 | 1.68 | 1.86 | 1.98 | 2.08 | 2.28 | 2.38 | 2.48 | 2.68 | 2.88 | 2.98 | 3.08 | 3.28 | 3.48 | 3.58 | 3.68 | | |
| | Sheave/Mtr | | | B | B | B | A | A | A | A | A | A | A | E | E | E | E | E | |
| | RPM | | | 506 | 541 | 572 | 605 | 633 | 661 | 690 | 716 | 744 | 769 | 793 | 820 | 843 | 868 | 891 | 913 |
| | Turns Open | | | 4.5 | 3.5 | 2.5 | 6 | 5.5 | 4.5 | 4 | 3 | 2.5 | 2 | 1.5 | 4 | 3 | 2.5 | 1.5 | 1 |
| 7600 | BHP | 1.68 | 1.78 | 1.88 | 2.08 | 2.26 | 2.38 | 2.48 | 2.68 | 2.86 | 2.98 | 3.08 | 3.28 | 3.46 | 3.58 | 3.68 | 3.88 | | |
| | Sheave/Mtr | | | B | B | B | A | A | A | A | A | A | D | E | E | E | E | E | |
| | RPM | | | 515 | 549 | 580 | 611 | 640 | 667 | 696 | 721 | 749 | 773 | 798 | 823 | 847 | 872 | 894 | 918 |
| | Turns Open | | | 4 | 3 | 2 | 6 | 5.5 | 4.5 | 3.5 | 3 | 2.5 | 2 | 1 | 3.5 | 3 | 2 | 1.5 | 1 |
| 7800 | BHP | 1.78 | 1.88 | 2.08 | 2.18 | 2.28 | 2.48 | 2.68 | 2.78 | 2.88 | 3.08 | 3.28 | 3.38 | 3.48 | 3.68 | 3.88 | 4.08 | | |
| | Sheave/Mtr | | | B | B | B | A | A | A | A | A | D | D | E | E | E | E | E | |
| | RPM | | | 525 | 556 | 586 | 617 | 645 | 674 | 701 | 726 | 753 | 778 | 804 | 827 | 850 | 875 | 897 | 921 |
| | Turns Open | | | 4 | 2.5 | 2 | 5.5 | 5 | 4 | 3.5 | 3 | 2.5 | 1.5 | 1 | 3.5 | 2.5 | 2 | 1.5 | 1 |
| 8000 | BHP | 1.88 | 2.08 | 2.18 | 2.28 | 2.48 | 2.68 | 2.88 | 2.98 | 3.08 | 3.28 | 3.48 | 3.58 | 3.68 | 3.88 | 4.08 | 4.28 | | |
| | Sheave/Mtr | | | B | B | B | A | A | A | A | D | D | E | E | E | E | E | E | |
| | RPM | | | 539 | 569 | 601 | 629 | 659 | 685 | 711 | 738 | 763 | 789 | 812 | 835 | 860 | 882 | 906 | 927 |
| | Turns Open | | | 3 | 2.5 | 1.5 | 5.5 | 4.5 | 4 | 3 | 2.5 | 2 | 1.5 | 4 | 3 | 2.5 | 2 | 1.5 | 1 |

A = Standard Static/Standard Motor, B = Low Static/Standard Motor, C = High Static/Standard Motor, D = Standard Static/Large Motor, E = High Static/Large Motor
 Unit factory shipped with standard static sheave and drive at 2.5 turns open. Other speed require field selection.

For applications requiring higher static pressures, contact your local representative. Performance data does not include drive losses and is based on sea level conditions.
 Do not operate in black regions. All airflow in rated at lowest Voltage if unit is dual Voltage rated, i.e. 208V for 208-230V units.

Blower Performance, Cont'd.

HKV 240 Blower Performance

All Data is Wet Coil

| Airflow (SCFM) | ESP | Airflow (cfm) at External Static Pressure (in. wg) | | | | | | | | | | | | | | | | |
|----------------|------------|--|------|------|------|------|------|------|------|------|------|------|------|------|------|------|------|-----|
| | | 0.00 | 0.10 | 0.20 | 0.30 | 0.40 | 0.50 | 0.60 | 0.70 | 0.80 | 0.90 | 1.00 | 1.10 | 1.20 | 1.30 | 1.40 | 1.50 | |
| 6000 | BHP | | | | 1.18 | 1.28 | 1.38 | 1.48 | 1.68 | 1.78 | 1.88 | 2.08 | 2.18 | 2.28 | 2.38 | 2.48 | 2.68 | |
| | Sheave/Mtr | | | | B | B | B | B | A | A | A | A | A | A | A | A | C | |
| | RPM | | | | 529 | 563 | 595 | 626 | 659 | 689 | 717 | 745 | 774 | 801 | 826 | 851 | 877 | |
| | Turns Open | | | | 6 | 5 | 4 | 3 | 6 | 5 | 4.5 | 4 | 3.5 | 2.5 | 2 | 1 | 5.5 | |
| 6200 | BHP | | | | 1.28 | 1.38 | 1.48 | 1.68 | 1.78 | 1.88 | 2.08 | 2.18 | 2.28 | 2.38 | 2.48 | 2.68 | 2.88 | |
| | Sheave/Mtr | | | | B | B | B | B | A | A | A | A | A | A | A | A | C | |
| | RPM | | | | 542 | 575 | 607 | 637 | 670 | 699 | 726 | 754 | 783 | 809 | 834 | 859 | 884 | |
| | Turns Open | | | | 5.5 | 4.5 | 3.5 | 3 | 5.5 | 5 | 4.5 | 3.5 | 3 | 2.5 | 1.5 | 1 | 5 | |
| 6400 | BHP | | | 1.28 | 1.38 | 1.48 | 1.68 | 1.78 | 1.88 | 2.08 | 2.18 | 2.28 | 2.48 | 2.58 | 2.68 | 2.88 | 3.06 | |
| | Sheave/Mtr | | | | B | B | B | B | A | A | A | A | A | A | A | C | C | |
| | RPM | | | | 520 | 556 | 588 | 619 | 649 | 680 | 708 | 736 | 765 | 791 | 817 | 841 | 868 | 891 |
| | Turns Open | | | | 6 | 5 | 4 | 3.5 | 6 | 5.5 | 4.5 | 4 | 3.5 | 2.5 | 2 | 1.5 | 5.5 | 5 |
| 6600 | BHP | | 1.38 | 1.48 | 1.68 | 1.78 | 1.88 | 2.08 | 2.18 | 2.28 | 2.48 | 2.58 | 2.68 | 2.88 | 2.98 | 3.08 | 3.08 | |
| | Sheave/Mtr | | | | B | B | B | B | A | A | A | A | A | A | A | C | C | |
| | RPM | | | | 537 | 570 | 601 | 631 | 662 | 691 | 718 | 745 | 774 | 799 | 824 | 849 | 875 | 898 |
| | Turns Open | | | | 5.5 | 4.5 | 4 | 3 | 5.5 | 5 | 4.5 | 3.5 | 3 | 2.5 | 2 | 1 | 5 | 4.5 |
| 6800 | BHP | | | 1.48 | 1.68 | 1.78 | 1.88 | 2.08 | 2.18 | 2.28 | 2.48 | 2.58 | 2.68 | 2.88 | 2.98 | 3.08 | 3.28 | |
| | Sheave/Mtr | | | | B | B | B | B | A | A | A | A | A | A | A | C | C | |
| | RPM | | | | 551 | 583 | 613 | 642 | 674 | 701 | 728 | 754 | 783 | 808 | 833 | 857 | 882 | 905 |
| | Turns Open | | | | 5.5 | 4.5 | 3.5 | 2.5 | 5.5 | 5 | 4 | 3.5 | 3 | 2 | 1.5 | 1 | 5 | 4.5 |
| 7000 | BHP | 1.48 | 1.68 | 1.78 | 1.88 | 2.08 | 2.18 | 2.28 | 2.48 | 2.58 | 2.68 | 2.88 | 3.08 | 3.18 | 3.28 | 3.48 | 3.48 | |
| | Sheave/Mtr | | | | B | B | B | B | A | A | A | A | A | A | C | C | C | |
| | RPM | 530 | 565 | 596 | 625 | 654 | 684 | 711 | 738 | 766 | 792 | 816 | 841 | 867 | 890 | 913 | 913 | |
| | Turns Open | 6 | 5 | 4 | 3 | 6 | 5 | 4.5 | 4 | 3 | 2.5 | 2 | 1.5 | 5.5 | 4.5 | 4 | 4 | |
| 7200 | BHP | 1.68 | 1.78 | 1.88 | 2.08 | 2.18 | 2.28 | 2.48 | 2.68 | 2.78 | 2.88 | 3.08 | 3.18 | 3.28 | 3.48 | 3.68 | 3.68 | |
| | Sheave/Mtr | | | | B | B | B | B | A | A | A | A | A | A | C | C | C | |
| | RPM | 544 | 578 | 608 | 637 | 668 | 695 | 722 | 748 | 776 | 800 | 825 | 849 | 874 | 897 | 920 | 920 | |
| | Turns Open | 5.5 | 4.5 | 3.5 | 2.5 | 5.5 | 5 | 4.5 | 3.5 | 3 | 2.5 | 1.5 | 1 | 5 | 4.5 | 4 | 4 | |
| 7400 | BHP | 1.78 | 1.88 | 2.08 | 2.28 | 2.38 | 2.48 | 2.68 | 2.78 | 2.88 | 3.08 | 3.28 | 3.38 | 3.48 | 3.68 | 3.88 | 3.88 | |
| | Sheave/Mtr | | | | B | B | B | B | A | A | A | A | A | C | C | C | C | |
| | RPM | 561 | 592 | 621 | 649 | 679 | 706 | 732 | 758 | 785 | 809 | 833 | 857 | 882 | 905 | 927 | 927 | |
| | Turns Open | 5 | 4 | 3 | 2.5 | 5.5 | 4.5 | 4 | 3.5 | 2.5 | 2 | 1.5 | 5.5 | 5 | 4.5 | 3.5 | 3.5 | |
| 7600 | BHP | 1.78 | 1.88 | 2.08 | 2.18 | 2.28 | 2.48 | 2.68 | 2.78 | 2.88 | 3.08 | 3.28 | 3.38 | 3.48 | 3.68 | 3.88 | 4.08 | |
| | Sheave/Mtr | | | | B | B | B | B | A | A | A | A | A | C | C | C | C | |
| | RPM | 544 | 575 | 605 | 633 | 661 | 691 | 717 | 742 | 767 | 794 | 818 | 842 | 867 | 890 | 912 | 934 | |
| | Turns Open | 5.5 | 4.5 | 3.5 | 3 | 5.5 | 5 | 4.5 | 4 | 3 | 2.5 | 2 | 1 | 5.5 | 5 | 4 | 3.5 | |
| 7800 | BHP | 1.88 | 2.08 | 2.28 | 2.38 | 2.48 | 2.68 | 2.88 | 2.98 | 3.08 | 3.28 | 3.48 | 3.58 | 3.68 | 3.88 | 4.08 | 4.28 | |
| | Sheave/Mtr | | | | B | B | B | B | A | A | A | A | A | C | C | C | C | |
| | RPM | 555 | 589 | 618 | 646 | 676 | 702 | 728 | 753 | 779 | 803 | 827 | 850 | 875 | 898 | 920 | 941 | |
| | Turns Open | 5 | 4 | 3 | 6 | 5.5 | 4.5 | 4 | 3.5 | 3 | 2 | 1.5 | 1 | 5 | 4.5 | 4 | 3.5 | |
| 8000 | BHP | 2.08 | 2.18 | 2.28 | 2.48 | 2.68 | 2.88 | 2.98 | 3.08 | 3.28 | 3.48 | 3.58 | 3.68 | 3.88 | 4.08 | 4.28 | 4.48 | |
| | Sheave/Mtr | | | | B | B | B | B | A | A | A | A | A | C | C | C | C | |
| | RPM | 572 | 601 | 630 | 657 | 686 | 712 | 737 | 762 | 789 | 812 | 836 | 859 | 883 | 905 | 927 | 948 | |
| | Turns Open | 4.5 | 3.5 | 3 | 5.5 | 5 | 4.5 | 4 | 3 | 2.5 | 2 | 1.5 | 5.5 | 5 | 4.5 | 4 | 3.5 | |
| 8200 | BHP | 2.28 | 2.38 | 2.48 | 2.68 | 2.88 | 2.98 | 3.08 | 3.28 | 3.48 | 3.68 | 3.78 | 3.88 | 4.08 | 4.28 | 4.48 | 4.68 | |
| | Sheave/Mtr | | | | B | B | B | B | A | A | A | A | A | C | C | C | C | |
| | RPM | 589 | 617 | 645 | 672 | 700 | 726 | 751 | 775 | 801 | 824 | 847 | 872 | 894 | 915 | 937 | 960 | |
| | Turns Open | 4 | 3.5 | 2.5 | 5.5 | 4.5 | 4 | 3.5 | 3 | 2.5 | 1.5 | 1 | 5.5 | 5 | 4.5 | 4 | 3 | |
| 8400 | BHP | 2.48 | 2.58 | 2.68 | 2.88 | 3.08 | 3.18 | 3.28 | 3.48 | 3.68 | 4 | 4.08 | 4.18 | 4.28 | 4.48 | 4.68 | 4.88 | |
| | Sheave/Mtr | | | | B | B | B | B | A | A | A | A | A | C | C | C | C | |
| | RPM | 605 | 633 | 660 | 689 | 714 | 739 | 763 | 790 | 813 | 836 | 858 | 882 | 904 | 925 | 946 | 969 | |
| | Turns Open | 3.5 | 3 | 5.5 | 5 | 4.5 | 4 | 3 | 2.5 | 2 | 1.5 | 1 | 5 | 4.5 | 4 | 3.5 | 3 | |

A = Standard Static/Standard Motor, B = Low Static/Standard Motor, C = High Static/Standard Motor, D = Standard Static/Large Motor, E = High Static/Large Motor
 Unit factory shipped with standard static sheave and drive at 2.5 turns open. Other speed require field selection.
 For applications requiring higher static pressures, contact your local representative. Performance data does not include drive losses and is based on sea level conditions. Do not operate in black regions. All airflow in rated at lowest Voltage if unit is dual Voltage rated, i.e. 208V for 208-230V units.

Table Continued on Next Page

Blower Performance, Cont'd.

Table Continued from Previous Page

All Data is Wet Coil

| Airflow (SCFM) | ESP | Airflow (cfm) at External Static Pressure (in. wg) | | | | | | | | | | | | | | | |
|----------------|------------|--|------|------|------|------|------|------|------|------|------|------|------|------|------|------|------|
| | | 0.00 | 0.10 | 0.20 | 0.30 | 0.40 | 0.50 | 0.60 | 0.70 | 0.80 | 0.90 | 1.00 | 1.10 | 1.20 | 1.30 | 1.40 | 1.50 |
| 8600 | BHP | 2.58 | 2.68 | 2.88 | 3.08 | 3.28 | 3.38 | 3.48 | 3.68 | 4 | 4.08 | 4.28 | 4.48 | 4.58 | 4.68 | 4.88 | 5.08 |
| | Sheave/Mtr | B | A | A | A | A | A | A | A | A | A | C | C | C | C | C | E |
| | RPM | 621 | 649 | 675 | 703 | 728 | 752 | 776 | 802 | 827 | 847 | 869 | 893 | 914 | 935 | 956 | 979 |
| | Turns Open | 3 | 6 | 5.5 | 4.5 | 4 | 3.5 | 3 | 2.5 | 2 | 1 | 5.5 | 5 | 4.5 | 4 | 3.5 | 2.5 |
| 8800 | BHP | 2.78 | 2.88 | 3.08 | 3.28 | 3.48 | 3.68 | 3.78 | 4 | 4.08 | 4.28 | 4.48 | 4.68 | 4.88 | 4.98 | 5.08 | 5.28 |
| | Sheave/Mtr | B | A | A | A | A | A | A | A | A | A | C | C | C | C | E | E |
| | RPM | 637 | 664 | 690 | 717 | 742 | 766 | 791 | 814 | 836 | 858 | 882 | 904 | 925 | 945 | 968 | 988 |
| | Turns Open | 2.5 | 5.5 | 5 | 4.5 | 3.5 | 3 | 2.5 | 2 | 1.5 | 1 | 5 | 4.5 | 4 | 3.5 | 3 | 2.5 |
| 9000 | BHP | 2.98 | 3.08 | 3.28 | 3.48 | 3.68 | 3.88 | 4.08 | 4.18 | 4.28 | 4.48 | 4.68 | 4.88 | 5.08 | 5.28 | 5.48 | 5.68 |
| | Sheave/Mtr | A | A | A | A | A | A | A | A | A | C | C | C | E | E | E | E |
| | RPM | 653 | 679 | 707 | 731 | 755 | 779 | 804 | 826 | 848 | 870 | 893 | 914 | 935 | 955 | 978 | 997 |
| | Turns Open | 6 | 5 | 4.5 | 4 | 3.5 | 3 | 2.5 | 2 | 1.5 | 5.5 | 5 | 4.5 | 4 | 3.5 | 2.5 | 2 |
| 9200 | BHP | 3.18 | 3.28 | 3.48 | 3.68 | 3.88 | 4.08 | 4.28 | 4.48 | 4.68 | 4.78 | 4.88 | 5.08 | 5.28 | 5.48 | 5.68 | 5.88 |
| | Sheave/Mtr | A | A | A | A | A | A | A | A | A | C | C | E | E | E | E | E |
| | RPM | 668 | 694 | 721 | 745 | 768 | 791 | 816 | 838 | 860 | 883 | 904 | 925 | 945 | 967 | 987 | 1007 |
| | Turns Open | 5.5 | 5 | 4 | 3.5 | 3 | 2.5 | 2 | 1.5 | 1 | 5 | 4.5 | 4 | 3.5 | 3 | 2.5 | 2 |
| 9400 | BHP | 3.48 | 3.68 | 3.78 | 3.88 | 4.08 | 4.28 | 4.48 | 4.68 | 4.88 | 5.08 | 5.28 | 5.38 | 5.48 | 5.68 | 5.88 | 6.08 |
| | Sheave/Mtr | A | A | A | A | A | A | A | A | C | E | E | E | E | E | E | E |
| | RPM | 683 | 711 | 735 | 758 | 782 | 806 | 828 | 850 | 871 | 894 | 915 | 935 | 955 | 977 | 997 | 1016 |
| | Turns Open | 5 | 4.5 | 4 | 3.5 | 3 | 2.5 | 2 | 1 | 5.5 | 5 | 4.5 | 4 | 3.5 | 3 | 2 | 2 |
| 9600 | BHP | 3.68 | 3.88 | 3.98 | 4.08 | 4.28 | 4.48 | 4.68 | 4.88 | 5.08 | 5.28 | 5.48 | 5.68 | 5.88 | 6.08 | 6.28 | 6.48 |
| | Sheave/Mtr | A | A | A | A | A | A | A | A | E | E | E | E | E | E | E | E |
| | RPM | 698 | 725 | 749 | 772 | 795 | 819 | 836 | 862 | 883 | 906 | 926 | 946 | 968 | 987 | 1007 | 1025 |
| | Turns Open | 4.5 | 4 | 3.5 | 3 | 2.5 | 2 | 1.5 | 1 | 5 | 4.5 | 4 | 3.5 | 3 | 2.5 | 2 | 1.5 |
| 9800 | BHP | 3.88 | 4.08 | 4.28 | 4.48 | 4.68 | 4.88 | 4.98 | 5.08 | 5.28 | 5.48 | 5.68 | 5.88 | 6.08 | 6.28 | 6.48 | 6.68 |
| | Sheave/Mtr | A | A | A | A | A | A | A | E | E | E | E | E | E | E | E | E |
| | RPM | 715 | 739 | 762 | 785 | 810 | 831 | 853 | 874 | 896 | 917 | 937 | 956 | 978 | 997 | 1016 | 1035 |
| | Turns Open | 4.5 | 4 | 3.5 | 3 | 2.5 | 1.5 | 1 | 5.5 | 4.5 | 4.5 | 3.5 | 3 | 3 | 2.5 | 2 | 1.5 |
| 10000 | BHP | 4.08 | 4.28 | 4.48 | 4.68 | 4.88 | 5.08 | 5.28 | 5.48 | 5.68 | 5.88 | 6.08 | 6.28 | 6.48 | 6.68 | 6.78 | 6.88 |
| | Sheave/Mtr | A | A | A | A | A | E | E | E | E | E | E | E | E | E | E | E |
| | RPM | 730 | 753 | 776 | 798 | 822 | 844 | 865 | 885 | 908 | 928 | 948 | 967 | 988 | 1007 | 1026 | 1044 |
| | Turns Open | 4 | 3.5 | 3 | 2.5 | 2 | 6 | 5.5 | 5 | 4.5 | 4 | 3.5 | 3 | 2.5 | 2 | 1.5 | 1 |

A = Standard Static/Standard Motor, B = Low Static/Standard Motor, C = High Static/Standard Motor, D = Standard Static/Large Motor, E = High Static/Large Motor
 Unit factory shipped with standard static sheave and drive at 2.5 turns open. Other speed require field selection.

For applications requiring higher static pressures, contact your local representative. Performance data does not include drive losses and is based on sea level conditions. Do not operate in black regions. All airflow in rated at lowest Voltage if unit is dual Voltage rated, i.e. 208V for 208-230V units.

Blower Performance Data, Cont'd.

HKV 300 Blower Performance

All Data is Wet Coil

| Airflow (SCFM) | ESP | Airflow (cfm) at External Static Pressure (in. wg) | | | | | | | | | | | | | | | |
|----------------|------------|--|------|------|------|------|------|------|------|------|------|------|------|------|------|------|------|
| | | 0.00 | 0.10 | 0.20 | 0.30 | 0.40 | 0.50 | 0.60 | 0.70 | 0.80 | 0.90 | 1.00 | 1.10 | 1.20 | 1.30 | 1.40 | 1.50 |
| 7600 | BHP | | | | | | 2.08 | 2.28 | 2.48 | 2.58 | 2.68 | 2.88 | 3.08 | 3.28 | 3.48 | 3.68 | 3.88 |
| | Sheave/Mtr | | | | | | B | B | B | B | A | A | A | A | A | A | A |
| | RPM | | | | | | 659 | 688 | 718 | 746 | 774 | 802 | 829 | 855 | 879 | 905 | 931 |
| | Turns Open | | | | | | 5.5 | 4.5 | 3.5 | 3 | 6 | 5 | 4.5 | 3.5 | 3 | 2 | 1.5 |
| 7800 | BHP | | | | | 2.08 | 2.28 | 2.38 | 2.48 | 2.68 | 2.88 | 3.08 | 3.28 | 3.48 | 3.68 | 3.88 | 4.06 |
| | Sheave/Mtr | | | | | | B | B | B | B | A | A | A | A | A | A | A |
| | RPM | | | | | | 639 | 669 | 702 | 729 | 757 | 785 | 811 | 838 | 862 | 887 | 913 |
| | Turns Open | | | | | | 5.5 | 5 | 4 | 3 | 2.5 | 5.5 | 5 | 4 | 3.5 | 2.5 | 2 |
| 8000 | BHP | | | | | 2.28 | 2.38 | 2.48 | 2.68 | 2.88 | 3.08 | 3.28 | 3.38 | 3.48 | 3.68 | 3.88 | 4.08 |
| | Sheave/Mtr | | | | | | B | B | B | B | A | A | A | A | A | A | A |
| | RPM | | | | | | 651 | 683 | 710 | 739 | 767 | 794 | 821 | 845 | 870 | 895 | 920 |
| | Turns Open | | | | | | 5.5 | 4.5 | 3.5 | 3 | 2 | 5.5 | 4.5 | 4 | 3 | 2.5 | 1.5 |
| 8200 | BHP | | | | 2.18 | 2.28 | 2.48 | 2.68 | 2.88 | 3.08 | 3.28 | 3.38 | 3.48 | 3.68 | 3.88 | 4.08 | 4.28 |
| | Sheave/Mtr | | | | | | B | B | B | B | A | A | A | A | A | A | C |
| | RPM | | | | | | 631 | 661 | 692 | 722 | 750 | 778 | 804 | 831 | 854 | 879 | 904 |
| | Turns Open | | | | | | 6 | 5 | 4 | 3.5 | 2.5 | 6 | 5 | 4.5 | 3.5 | 3 | 2 |
| 8400 | BHP | | | | 2.28 | 2.48 | 2.68 | 2.88 | 3.08 | 3.18 | 3.28 | 3.48 | 3.68 | 3.88 | 4.08 | 4.28 | 4.48 |
| | Sheave/Mtr | | | | | | B | B | B | B | A | A | A | A | A | A | C |
| | RPM | | | | | | 640 | 673 | 703 | 733 | 761 | 788 | 812 | 838 | 863 | 888 | 912 |
| | Turns Open | | | | | | 5.5 | 5 | 4 | 3 | 2 | 5.5 | 5 | 4 | 3.5 | 2.5 | 2 |
| 8600 | BHP | | | | 2.48 | 2.68 | 2.88 | 3.08 | 3.18 | 3.28 | 3.48 | 3.68 | 3.88 | 4.08 | 4.28 | 4.48 | 4.68 |
| | Sheave/Mtr | | | | | | B | B | B | A | A | A | A | A | A | A | C |
| | RPM | | | | | | 653 | 685 | 715 | 744 | 771 | 796 | 822 | 847 | 872 | 896 | 919 |
| | Turns Open | | | | | | 5.5 | 4.5 | 3.5 | 2.5 | 6 | 5.5 | 4.5 | 4 | 3 | 2.5 | 1.5 |
| 8800 | BHP | | | 2.48 | 2.68 | 2.88 | 3.08 | 3.18 | 3.28 | 3.48 | 3.68 | 3.88 | 4.08 | 4.28 | 4.48 | 4.68 | 4.88 |
| | Sheave/Mtr | | | | | | B | B | B | B | A | A | A | A | A | A | C |
| | RPM | | | | | | 633 | 666 | 697 | 726 | 755 | 782 | 806 | 832 | 857 | 881 | 904 |
| | Turns Open | | | | | | 6 | 5 | 4 | 3 | 2.5 | 5.5 | 5 | 4 | 3.5 | 3 | 2 |
| 9000 | BHP | | 2.6 | 2.8 | 3 | 3.2 | 3.4 | 3.6 | 3.8 | 4 | 4.2 | 4.4 | 4.6 | 4.8 | 5 | 5.2 | |
| | Sheave/Mtr | | | | | | B | B | B | A | A | A | A | A | A | C | E |
| | RPM | | | | | | 646 | 678 | 706 | 735 | 763 | 791 | 817 | 842 | 867 | 889 | 912 |
| | Turns Open | | | | | | 5.5 | 4.5 | 3.5 | 3 | 2 | 5.5 | 4.5 | 4 | 3 | 2.5 | 2 |
| 9200 | BHP | | 2.68 | 2.88 | 3.08 | 3.28 | 3.48 | 3.68 | 3.88 | 4.08 | 4.28 | 4.48 | 4.68 | 4.88 | 5.08 | 5.28 | |
| | Sheave/Mtr | | | | | | B | B | B | A | A | A | A | A | A | E | E |
| | RPM | | | | | | 656 | 687 | 715 | 744 | 772 | 799 | 825 | 850 | 872 | 896 | 919 |
| | Turns Open | | | | | | 5.5 | 4.5 | 3.5 | 2.5 | 6 | 5 | 4.5 | 3.5 | 3 | 2.5 | 2 |
| 9400 | BHP | | 2.68 | 2.88 | 3.08 | 3.28 | 3.48 | 3.68 | 3.88 | 4.08 | 4.28 | 4.48 | 4.68 | 4.88 | 5.08 | 5.28 | 5.48 |
| | Sheave/Mtr | | | | | | B | B | B | A | A | A | A | A | E | E | E |
| | RPM | | | | | | 637 | 666 | 697 | 727 | 755 | 783 | 809 | 835 | 858 | 882 | 905 |
| | Turns Open | | | | | | 6 | 5 | 4 | 3 | 2.5 | 5.5 | 5 | 4 | 3.5 | 2.5 | 2 |
| 9600 | BHP | | 2.88 | 3.08 | 3.28 | 3.48 | 3.68 | 3.88 | 4.08 | 4.28 | 4.48 | 4.68 | 4.88 | 5.08 | 5.28 | 5.48 | 5.68 |
| | Sheave/Mtr | | | | | | B | B | B | A | A | A | A | D | E | E | E |
| | RPM | | | | | | 647 | 678 | 708 | 738 | 766 | 793 | 819 | 844 | 867 | 891 | 914 |
| | Turns Open | | | | | | 5.5 | 4.5 | 3.5 | 3 | 6 | 5 | 4.5 | 4 | 3 | 2.5 | 2 |
| 9800 | BHP | 2.88 | 3.08 | 3.28 | 3.48 | 3.68 | 3.88 | 4.08 | 4.28 | 4.48 | 4.68 | 4.88 | 5.08 | 5.28 | 5.48 | 5.68 | 5.88 |
| | Sheave/Mtr | | | | | | B | B | B | A | A | A | A | D | E | E | E |
| | RPM | | | | | | 631 | 662 | 690 | 720 | 749 | 777 | 803 | 827 | 852 | 877 | 900 |
| | Turns Open | | | | | | 6 | 5 | 4 | 3.5 | 2.5 | 5.5 | 5 | 4.5 | 3.5 | 2.5 | 2 |
| 10000 | BHP | 3.08 | 3.28 | 3.48 | 3.68 | 3.88 | 4.08 | 4.28 | 4.48 | 4.68 | 4.88 | 5.08 | 5.28 | 5.48 | 5.68 | 5.88 | 6.08 |
| | Sheave/Mtr | | | | | | B | B | B | A | A | A | D | D | E | E | E |
| | RPM | | | | | | 642 | 672 | 702 | 731 | 760 | 785 | 811 | 837 | 862 | 886 | 909 |
| | Turns Open | | | | | | 5.5 | 4.5 | 4 | 3 | 2 | 5.5 | 4.5 | 4 | 3.5 | 2.5 | 2 |
| 10200 | BHP | 3.28 | 3.48 | 3.68 | 3.88 | 4.08 | 4.28 | 4.48 | 4.68 | 4.88 | 5.08 | 5.28 | 5.48 | 5.68 | 5.88 | 6.08 | 6.38 |
| | Sheave/Mtr | | | | | | B | B | B | A | A | A | D | D | E | E | E |
| | RPM | | | | | | 655 | 685 | 714 | 743 | 769 | 798 | 822 | 847 | 872 | 896 | 917 |
| | Turns Open | | | | | | 5 | 4.5 | 3.5 | 2.5 | 6 | 5 | 4.5 | 3.5 | 3 | 2.5 | 2 |
| 10400 | BHP | 3.48 | 3.68 | 3.88 | 4.08 | 4.28 | 4.48 | 4.68 | 4.88 | 5.08 | 5.28 | 5.48 | 5.68 | 5.88 | 6.18 | 6.38 | 6.58 |
| | Sheave/Mtr | | | | | | B | B | B | A | A | A | D | D | E | E | E |
| | RPM | | | | | | 668 | 697 | 726 | 752 | 782 | 806 | 832 | 857 | 882 | 903 | 926 |
| | Turns Open | | | | | | 5 | 4 | 3 | 2.5 | 5.5 | 5 | 4 | 3.5 | 2.5 | 2 | 1.5 |
| 10600 | BHP | 3.68 | 3.88 | 4.08 | 4.28 | 4.48 | 4.68 | 4.88 | 5.08 | 5.28 | 5.48 | 5.68 | 5.88 | 6.18 | 6.38 | 6.58 | 6.78 |
| | Sheave/Mtr | | | | | | B | B | B | A | A | D | D | D | E | E | E |
| | RPM | | | | | | 680 | 709 | 737 | 763 | 790 | 817 | 842 | 867 | 889 | 912 | 935 |
| | Turns Open | | | | | | 4.5 | 3.5 | 3 | 2 | 5.5 | 4.5 | 4 | 3 | 2.5 | 2 | 1.5 |

A = Standard Static/Standard Motor, B = Low Static/Standard Motor, C = High Static/Standard Motor, D = Standard Static/Large Motor, E = High Static/Large Motor
 Unit factory shipped with standard static sheave and drive at 2.5 turns open. Other speed require field selection.

For applications requiring higher static pressures, contact your local representative. Performance data does not include drive losses and is based on sea level conditions. Do not operate in black regions. All airflow in rated at lowest Voltage if unit is dual Voltage rated, i.e. 208V for 208-230V units.

Table Continued on Next Page

Blower Performance, Cont'd.

Table Continued from Previous Page

All Data is Wet Coil

| Airflow (SCFM) | ESP | Airflow (cfm) at External Static Pressure (in. wg) | | | | | | | | | | | | | | | |
|----------------|------------|--|------|------|------|------|------|------|------|------|------|------|------|------|------|------|------|
| | | 0.00 | 0.10 | 0.20 | 0.30 | 0.40 | 0.50 | 0.60 | 0.70 | 0.80 | 0.90 | 1.00 | 1.10 | 1.20 | 1.30 | 1.40 | 1.50 |
| 10800 | BHP | 3.88 | 4.08 | 4.28 | 4.48 | 4.68 | 4.88 | 5.08 | 5.28 | 5.48 | 5.68 | 5.88 | 6.18 | 6.38 | 6.58 | 6.78 | 6.98 |
| | Sheave/Mtr | B | B | B | A | A | A | D | D | D | D | E | E | E | E | E | E |
| | RPM | 691 | 717 | 745 | 772 | 799 | 825 | 850 | 873 | 897 | 920 | 943 | 965 | 986 | 1006 | 1026 | 1047 |
| | Turns Open | 4.5 | 3.5 | 2.5 | 6 | 5 | 4.5 | 3.5 | 3 | 2 | 1.5 | 3.5 | 3 | 2.5 | 2 | 1.5 | 1 |
| 11000 | BHP | 4.08 | 4.28 | 4.48 | 4.68 | 4.88 | 5.08 | 5.28 | 5.48 | 5.68 | 6.18 | 6.28 | 6.48 | 6.68 | 6.88 | 7.08 | 7.38 |
| | Sheave/Mtr | B | B | B | A | A | D | D | D | D | E | E | E | E | E | E | E |
| | RPM | 704 | 729 | 756 | 783 | 810 | 836 | 859 | 883 | 907 | 929 | 952 | 972 | 993 | 1014 | 1035 | 1055 |
| | Turns Open | 3.5 | 3 | 2 | 5.5 | 5 | 4 | 3 | 2.5 | 2 | 1.5 | 3.5 | 3 | 2.5 | 2 | 1 | 0.5 |
| 11200 | BHP | 4.28 | 4.48 | 4.68 | 4.88 | 5.08 | 5.28 | 5.48 | 5.68 | 6.00 | 6.28 | 6.48 | 6.68 | 6.88 | 7.08 | 7.38 | |
| | Sheave/Mtr | B | B | A | A | D | D | D | D | D | E | E | E | E | E | E | |
| | RPM | 714 | 740 | 767 | 794 | 818 | 844 | 868 | 892 | 916 | 938 | 959 | 981 | 1002 | 1023 | 1043 | |
| | Turns Open | 3.5 | 2.5 | 6 | 5.5 | 4.5 | 3.5 | 3 | 2.5 | 1.5 | 1 | 3 | 2.5 | 2 | 1.5 | 1 | |
| 11400 | BHP | 4.48 | 4.68 | 4.88 | 5.08 | 5.28 | 5.48 | 5.78 | 6.08 | 6.28 | 6.48 | 6.68 | 6.88 | 7.18 | 7.48 | | |
| | Sheave/Mtr | B | B | A | D | D | D | D | D | D | E | E | E | E | E | | |
| | RPM | 726 | 752 | 779 | 803 | 829 | 854 | 878 | 902 | 925 | 948 | 970 | 990 | 1011 | 1031 | | |
| | Turns Open | 3 | 2 | 5.5 | 5 | 4.5 | 3.5 | 3 | 2 | 1.5 | 1 | 3 | 2.5 | 2 | 1.5 | | |
| 11600 | BHP | 4.68 | 4.88 | 5.08 | 5.28 | 5.48 | 5.68 | 6.00 | 6.28 | 6.48 | 6.68 | 6.88 | 7.18 | 7.48 | | | |
| | Sheave/Mtr | B | A | D | D | D | D | D | D | D | E | E | E | E | | | |
| | RPM | 738 | 763 | 788 | 813 | 839 | 864 | 888 | 911 | 934 | 955 | 977 | 998 | 1019 | | | |
| | Turns Open | 2.5 | 6 | 5.5 | 4.5 | 4 | 3 | 2.5 | 2 | 1 | 3.5 | 2.5 | 2 | 1.5 | | | |
| 11800 | BHP | 4.88 | 5.08 | 5.28 | 5.48 | 5.78 | 6.08 | 6.28 | 6.48 | 6.68 | 6.98 | 7.28 | 7.48 | | | | |
| | Sheave/Mtr | B | D | D | D | D | D | D | D | D | E | E | E | | | | |
| | RPM | 750 | 775 | 799 | 824 | 849 | 874 | 898 | 921 | 944 | 964 | 986 | 1007 | | | | |
| | Turns Open | 2 | 5.5 | 5 | 4 | 3.5 | 3 | 2.5 | 2 | 1 | 3 | 2.5 | 2 | | | | |
| 12000 | BHP | 5.08 | 5.28 | 5.48 | 5.78 | 6.08 | 6.28 | 6.48 | 6.68 | 6.98 | 7.28 | 7.48 | | | | | |
| | Sheave/Mtr | D | D | D | D | D | D | D | D | E | E | E | | | | | |
| | RPM | 758 | 783 | 808 | 833 | 858 | 880 | 904 | 927 | 950 | 972 | 993 | | | | | |
| | Turns Open | 6 | 5.5 | 4.5 | 4 | 3.5 | 2.5 | 2 | 1.5 | 3.5 | 3 | 2.5 | | | | | |
| 12200 | BHP | 5.28 | 5.48 | 5.78 | 6.08 | 6.28 | 6.48 | 6.68 | 6.98 | 7.28 | 7.48 | | | | | | |
| | Sheave/Mtr | D | D | D | D | D | D | D | D | E | E | | | | | | |
| | RPM | 769 | 794 | 819 | 843 | 866 | 890 | 913 | 936 | 958 | 980 | | | | | | |
| | Turns Open | 6 | 5 | 4.5 | 4 | 3 | 2.5 | 2 | 1.5 | 3 | 2.5 | | | | | | |
| 12400 | BHP | 5.68 | 5.88 | 6.08 | 6.28 | 6.48 | 6.78 | 7.08 | 7.28 | 7.48 | | | | | | | |
| | Sheave/Mtr | D | D | D | D | D | D | D | D | E | | | | | | | |
| | RPM | 781 | 815 | 830 | 854 | 878 | 900 | 923 | 946 | 968 | | | | | | | |
| | Turns Open | 5.5 | 4.5 | 4.5 | 3.5 | 3 | 2 | 1.5 | 1 | 3 | | | | | | | |
| 12600 | BHP | 5.88 | 6.08 | 6.28 | 6.58 | 6.88 | 7.08 | 7.28 | | | | | | | | | |
| | Sheave/Mtr | D | D | D | D | D | D | D | | | | | | | | | |
| | RPM | 793 | 817 | 841 | 863 | 886 | 910 | 933 | | | | | | | | | |
| | Turns Open | 5 | 4.5 | 4 | 3 | 2.5 | 2 | 1.5 | | | | | | | | | |

A = Standard Static/Standard Motor, B = Low Static/Standard Motor, C = High Static/Standard Motor, D = Standard Static/Large Motor, E = High Static/Large Motor
 Unit factory shipped with standard static sheave and drive at 2.5 turns open. Other speed require field selection.
 For applications requiring higher static pressures, contact your local representative. Performance data does not include drive losses and is based on sea level conditions.
 Do not operate in black regions. All airflow in rated at lowest Voltage if unit is dual Voltage rated, i.e. 208V for 208-230V units.

Unit Commissioning & Operating Conditions

Environment - This unit is designed for indoor installation only. Do not install in an area subject to freezing or where humidity levels can cause cabinet condensation.

Power Supply - A voltage variation of +/- 10% of nameplate utilization voltage is acceptable.

Operation and performance is primarily dependent upon return air temperature, airflow, water temperature, water flow rate and ambient air temperature. This water to air heat pump is capable of operating over a wide temperature range and with flow rates of between 1.5 GPM (.1 l/s) and 3 GPM (.19 l/s) per ton, however usually no more than one of these factors may be at a minimum or maximum level at a time.

The commissioning table indicates air and water temperatures which are suitable for initial unit commissioning in an environment where the flow rate and water temperature is not yet stable and to avoid nuisance shut down of the units freeze and refrigerant pressure safeties.

The operating table indicates the maximum and minimum ranges of the unit.

For more specific unit performance reference the product catalog, the submittal data sheets or contact your supplier for assistance.

Table 11a: Building Commissioning

| BUILDING COMMISSIONING | | |
|--|-----------------|-----------------|
| | ALL HKV MODELS | |
| | Cooling °F [°C] | Heating °F [°C] |
| AMBIENT MIN - MAX DB | 45-110 [7-43] | 40-85 [4.5-29] |
| RETURN AIR MIN DB/WB | 50/45 [10/7] | 40 [4.5] |
| RETURN AIR MAX DB/WB | 110/83 [43/28] | 85 [29] |
| STANDARD UNIT ENTERING WATER MIN* - MAX | 40-120 [4.5-49] | 60-90 [16-43] |
| EXTENDED RANGE UNIT** ENTERING WATER MIN* - MAX | 30-120 [-1-49] | 20-90 [-6.7-43] |

*- Requires optional insulation package when operating below the dew point

** - Requires antifreeze, optional insulation package and jumper clipped.

Table 11b: Unit Operating Limits

| UNIT OPERATING LIMITS | | |
|--|-----------------|-----------------|
| | All HKV Models | |
| | Cooling °F [°C] | Heating °F [°C] |
| AMBIENT MIN - MAX DB | 50-100 [10-38] | 50-85 [10-29] |
| RETURN AIR MIN DB/WB*** | 65/55 [18/12.8] | 60 [16] |
| RETURN AIR MAX DB/WB | 95/75 [35/24] | 80 [27] |
| STANDARD UNIT ENTERING WATER MIN* - MAX | 50-120 [10-49] | 60-90 [16-43] |
| EXTENDED RANGE UNIT** ENTERING WATER MIN* - MAX | 30-120 [-1-49] | 20-90 [-6.7-43] |

*- Requires optional insulation package when operating below the dew point

** - Requires antifreeze, optional insulation package and jumper clipped.

*** - Return air min. can be 50DB for units with hot gas bypass option

Piping System Cleaning & Flushing

⚠ CAUTION! ⚠

CAUTION! To avoid possible damage to a plastic (PVC) piping system, do not allow temperatures to exceed 110°F [43°C].

⚠ CAUTION! ⚠

CAUTION! DO NOT use 'stop leak' or any similar chemical agent in this system. Addition of these chemicals to the loop water will foul the system and inhibit unit operation.

Note: Heat Controller strongly recommends all piping connections, both internal and external to the unit, be pressure tested for leakage by an appropriate method prior to any finishing of the interior space or before access to all connections is limited. Heat Controller will not be responsible or liable for damages from water leaks due to inadequate or a lack of pressurized leak testing during installation.

Cleaning and flushing of the WLHP piping system is the single most important step to ensure proper start-up and continued efficient operation of the system.

Follow the instructions below to properly clean and flush the system:

1. Verify electrical power to the unit is disconnected.
2. Install the system with the supply hose connected directly to the return riser valve. Use a single length of flexible hose.
3. Open all air vents. Fill the system with the water. DO NOT allow system to overflow. Bleed all air from the system. Pressurize and check the system for leaks and repair appropriately.
4. Verify all strainers are in place. (Heat Controller recommends a strainer with a #20 stainless steel wire mesh.) Start the pumps, and systematically check each vent to ensure all air is bled from the system.
5. Verify make-up water is available. Adjust make-up water appropriately to replace the air which was bled from the system. Check and adjust the water/air level in the expansion tank.
6. Set the boiler to raise the loop temperature to approximately 85°F [29°C]. Open the a drain at the lowest point in the system. Adjust the make-up water replacement rate to equal the rate of bleed.
7. Refill the system and add trisodium phosphate in a proportion of approximately one pound per 150 gallons [1/2 kg per 750 L] of water (or other equivalent approved cleaning agent). Reset the boiler to raise the loop temperature to about 100°F [38°C]. Circulate the solution for a minimum of 8 to 24 hours. At the end of this period, shut off the circulating pump and drain the solution. Repeat system cleaning if desired.
8. When the cleaning process is complete, remove the short-circuited hoses. Reconnect the hoses to the proper supply, and return the connections to each of the units. Refill the system and bleed off all air.
9. Test the system pH with litmus paper. The system water should be slightly alkaline (pH 7.5-8.5). Add chemicals, as appropriate, to maintain acidity levels.
10. When the system is successfully cleaned, flushed, refilled and bled, check the main system panels, safety cutouts and alarms. Set the controls to properly maintain loop temperatures.

Unit & System Checkout

WARNING!

WARNING! Polyolester Oil, commonly known as POE oil, is a synthetic oil used in many refrigeration systems including those with HFC-410A refrigerant. POE oil, if it ever comes in contact with PVC or CPVC piping, may cause failure of the PVC/CPVC. PVC/CPVC piping should never be used as supply or return water piping with water source heat pump products containing HFC-410A as system failures and property damage may result.

BEFORE POWERING SYSTEM, please check the following:

UNIT CHECKOUT

- Line Voltage and Wiring: Ensure Voltage is within an acceptable range for the unit and wiring and fuses/ breakers are properly sized. Low voltage wiring is complete.
- Unit Control Transformer: Ensure transformer has properly selected control voltage tap. 208-230V units are factory wired for 208V operation unless specified otherwise.
- Balancing/Shutoff Valves: Ensure all isolation valves are open (after system flushing - see System Checkout) water control valves wired and open or coax may freeze and burst.
- Entering Water and Air: Ensure entering water and air temperatures are within operating limits of Table 11b.
- Low Water Temperature Cutout: Verify low water temperature cut-out on CXM2/DXM2.5 is properly set.
- Unit Blower Wheel: Manually rotate blower wheel to verify free rotation and ensure that all blower wheels are secured to blower shaft and centered in housing.
- Blower Motor: Verify motor bolts are tight. DO NOT oil motors upon start-up. Fan motors are pre-oiled at factory.
- Check shaft pillow blocks, sheave and pulley are tight
- Verify sheave has been set to turns in design requirement. Record turns on start up log sheet.
- Verify belt is straight and proper tension
- Condensate Line: Condensate line is open, trapped, vented, and properly pitched toward drain.
- Water Flow Balancing: Verify inlet and outlet water temperatures are recorded for each heat pump upon startup. This check can eliminate nuisance trip outs and high velocity water flows that can erode heat exchangers.

- Unit Air Coil & Filters: Ensure filter is clean and accessible. To obtain maximum performance and avoid possible condensate blow-off the coil should be cleaned using a 10% solution of dish washing detergent.
- Unit Controls: Verify CXM2 or DXM2.5 field selection options are proper and complete.

SYSTEM CHECKOUT

- System Water Temperature: Check water temperature for proper range and also verify heating and cooling setpoints for proper operation.
- System pH: System water pH is 7.5 - 8.5. Proper pH promotes longevity of hoses and fittings.
- System Flushing: Verify all hoses are connected end to end when flushing to ensure debris bypasses unit heat exchanger and water valves etc. Water used in the system must be potable quality initially and clean of dirt, piping slag, and strong chemical cleaning agents. Verify all air is purged from the system. Air in the system can cause poor operation or system corrosion.
- Cooling Tower/Boiler: Check equipment for proper setpoints and operation.
- Standby Pumps: Verify the standby pump is properly installed and in operating condition.
- System Controls: Verify system controls function and operate in the proper sequence.
- Low Water Temperature Cutout: Verify low water temperature cut-out controls are provided for the outdoor portion of the loop or operating problems will occur.
- System Control Center: Verify control center and alarm panel for proper setpoints and operation (if used).
- Miscellaneous: Note any questionable aspects of the installation.
- Log Data: Record data on startup log sheet in this manual or on web site. keep log for future reference.

WARNING!

WARNING! Verify ALL water controls are open and allow water flow prior to engaging the compressor. Freezing of the coax or water lines can permanently damage the heat pump.

WARNING!

WARNING! To avoid equipment damage, DO NOT leave system filled in a building without heat during the winter unless antifreeze is added to system water. Condenser coils never fully drain by themselves and will freeze unless winterized with antifreeze.

Unit Start-Up Procedure

⚠ WARNING! ⚠

WARNING! When the disconnect switch is closed, high voltage is present in some areas of the electrical panel. Exercise caution when working with energized equipment.

⚠ CAUTION! ⚠

INSTALLER CAUTION! After making water connections on units equipped with ClimaDry®, ensure the three union nuts on the internal three-way water valve are tight.

1. Turn thermostat fan position to "ON". Blower should start.
2. Balance air flow at registers.
3. Adjust all valves to their full open position. Turn on the line power to all heat pump units.
4. Operate unit in cooling cycle. Room temperature should be approximately 45-100°F [7-38°C] DB.
For Start-up check, loop water temperature entering the heat pumps should be between 45°F [7°C] and 110°F [43°C].
5. Two factors determine the operating limits of a Heat Controller HKV System– (a) return air temperature, and (b) water temperature. When any one of these factors is at a minimum or maximum level, the other factor must be at normal levels to ensure proper unit operation.
 - a. Adjust the unit thermostat to the warmest position. Slowly reduce thermostat setting until the compressor activates.
 - b. Check for cool air delivery at the unit grille within a few minutes after the unit has begun to operate.
Note: Units have a five minute time delay in the control circuit that can be eliminated on the CXM2 PCB as shown below in Figure 14. See controls description for detailed features of the control.
 - c. Verify that the compressor is on and that the water flow rate is correct by measuring pressure drop through the heat exchanger using the Pete's plugs and comparing to Table 12.
 - d. Check the elevation and cleanliness of the condensate lines. Dripping may be a sign of a blocked line. Check that the condensate trap includes a water seal.
 - e. Refer to Table 14. Check the temperature of both supply and discharge water. If temperature is within range, proceed with test. If temperature is outside operating range, check cooling refrigerant pressures in Table 13. Verify correct water flow by comparing unit pressure drop across the heat exchanger versus the data in Table 14. Heat of rejection can be calculated and compared to specification catalog.
 - f. Check air temperature drop across the coil when compressor is operating. Air temperature should drop between 15°F [8°C] and 25°F [14°C].
 - g. Turn thermostat to "OFF" position. A hissing noise indicates proper functioning of the reversing valve.
6. Operate the heat pump in the heating cycle immediately after checking cooling cycle operation. Allow five (5) minutes between tests for pressure to equalize or cycle the reversing valve to equalize.
 - a. Turn thermostat to lowest setting and set thermostat switch to "HEAT" position.
 - b. Slowly turn thermostat to a higher temperature until the compressor activates.
 - c. Check for warm air delivery at the unit grille within a few minutes after the unit has begun to operate.
 - d. Check the temperature of both supply and discharge water. Refer to Table 13. If temperature is within range, proceed with test. If temperature is outside operating range, check heating refrigerant pressures in Table 13.
 - e. Check air temperature rise across the coil when compressor is operating. Air temperature should rise between 20°F [11°C] and 30°F [17°C]. Heat of extraction can be calculated and compared to specification catalog.
 - f. Check for vibration, noise, and water leaks.
7. If unit fails to operate, perform troubleshooting analysis (CXM2 AOM or DXM2.5 AOM). If the check described fails to reveal the problem and the unit still does not operate, contact a trained service technician to ensure proper diagnosis and repair of the equipment.
8. When testing is complete, set system to maintain desired comfort level.
9. BE CERTAIN TO FILL OUT AND FORWARD ALL WARRANTY REGISTRATION PAPERS TO Heat Controller.

Note: If performance during any mode appears abnormal, refer to the troubleshooting section of CXM2 or DXM2.5 AOM. To obtain maximum performance the air coil should be cleaned before start-up. A 10% solution of dishwasher detergent and water is recommended.

Figure 14: Test Mode Button

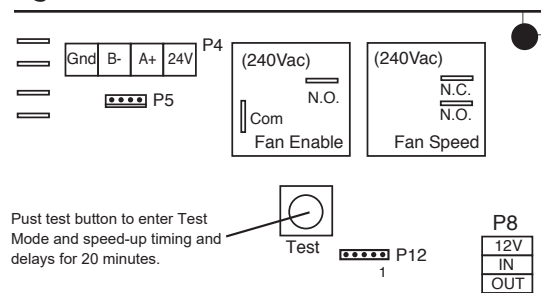

Table 12: Coax Water Pressure Drop

| Model | GPM | Pressure Drop | | | |
|--------|-------|---------------|------|------|------|
| | | 30°F | 50°F | 70°F | 90°F |
| HKV084 | 10.5 | 2.4 | 2.0 | 1.2 | 1.1 |
| | 15.75 | 5.5 | 4.6 | 3.4 | 3.0 |
| | 21 | 9.2 | 7.9 | 6.2 | 5.7 |
| HKV096 | 12 | 3.8 | 3.1 | 2.3 | 2.0 |
| | 18 | 8.0 | 6.8 | 5.3 | 4.8 |
| | 24 | 13.0 | 11.2 | 9.2 | 8.6 |
| HKV120 | 15 | 2.1 | 1.7 | 1.2 | 1.0 |
| | 22.5 | 5.3 | 4.4 | 3.5 | 3.2 |
| | 30 | 9.4 | 8.1 | 6.7 | 6.2 |
| HKV150 | 19 | 2.7 | 2.1 | 1.5 | 1.3 |
| | 28 | 6.2 | 5.2 | 4.1 | 3.7 |
| | 38 | 11.0 | 9.5 | 7.7 | 7.2 |

| Model | GPM | Pressure Drop | | | |
|--------|------|---------------|------|------|------|
| | | 30°F | 50°F | 70°F | 90°F |
| HKV168 | 21 | 2.7 | 2.2 | 1.4 | 1.2 |
| | 31.5 | 6.1 | 5.2 | 3.8 | 3.4 |
| | 42 | 10.4 | 8.9 | 6.9 | 6.4 |
| HKV192 | 24 | 4.2 | 3.5 | 2.6 | 2.3 |
| | 36 | 9.0 | 7.6 | 6.0 | 5.5 |
| | 48 | 14.6 | 12.6 | 10.3 | 9.6 |
| HKV240 | 30 | 2.4 | 1.9 | 1.3 | 1.1 |
| | 45 | 5.9 | 4.9 | 3.9 | 3.6 |
| | 60 | 10.5 | 9.2 | 7.5 | 7.0 |
| HKV300 | 38 | 3.1 | 2.4 | 1.7 | 1.5 |
| | 56 | 7.0 | 5.9 | 4.6 | 4.2 |
| | 76 | 12.4 | 10.7 | 8.7 | 8.1 |

CXM2/DXM2.5 Safety Control Reset - Lockout - In Lockout mode, the Status LED will begin fast flashing. The compressor relay is turned off immediately. Lockout mode can be soft reset via the thermostat "Y" input or can be hard reset via the disconnect. The last fault causing the lockout will be stored in memory and can be viewed by going into test mode.

Fault Retry - In Fault Retry mode, the Status LED begins slow flashing to signal that the control is trying to recover from a fault input. The CXM2 control will stage off the outputs and then "try again" to satisfy the thermostat "Y" input call. Once the thermostat input calls are satisfied, the control will continue on as if no fault occurred. If 3 consecutive faults occur without satisfying the thermostat "Y" input call, then the control will go to Lockout mode. The last fault causing the lockout will be stored in memory and can be viewed by going into test mode.

Consult the CXM2 AOM or DXM2.5 AOM for complete descriptions.

CAUTION!

CAUTION! Do not restart units without inspection and remedy of faulting condition. Equipment damage may occur.

Start-Up Log Sheet

Installer: Complete unit and system checkout and follow unit start-up procedures in the IOM. Use this form to record unit information, temperatures and pressures during start-up. Keep this form for future reference.

Job Name: _____ **Street Address:** _____

Model Number: _____ **Serial Number:** _____

Unit Location in Building: _____

Date: _____ **Sales Order No:** _____

In order to minimize troubleshooting and costly system failures, complete the following checks and data entries before the system is put into full operation.

Externat Static: _____

Sheave Setting: _____ **Turns OPEN**

Temperatures: F or C

Antifreeze: _____ %

Pressures: PSIG or kPa

Type: _____

| | Cooling Mode | Heating Mode |
|---|--------------|--------------|
| Return-Air Temperature | DB | WB DB |
| Supply-Air Temperature | DB | WB DB |
| Temperature Differential | | |
| Entering Fluid Temperature | | |
| Leaving Fluid Temperature | | |
| Temperature Differential | | |
| Water Coil Heat Exchanger (Water Pressure IN) | | |
| Water Coil Heat Exchanger (Water Pressure OUT) | | |
| Pressure Differential | | |
| Compressor | | |
| Amps | | |
| Volts | | |
| Discharge Line Temperature | | |
| Flow Rate GPM (l/s) | | |
| Motor | | |
| Amps | | |
| Volts | | |

Allow unit to run 15 minutes in each mode before taking data

Do not connect gauge lines

Unit Operating Conditions

Table 13: Typical Unit Operating Pressures and Temperatures

| Entering Water Temp °F | GPM per ton | Cooling | | | | | | Heating | | | | | |
|------------------------|-------------|-----------------------|-------------------------|------------|-------------|--------------------|---------------------|-----------------------|-------------------------|------------|-------------|--------------------|---------------------|
| | | Suction Pressure PSIG | Discharge Pressure PSIG | Super-heat | Sub-cooling | Water Temp Rise °F | Air Temp Drop °F DB | Suction Pressure PSIG | Discharge Pressure PSIG | Super-heat | Sub-cooling | Water Temp Drop °F | Air Temp Rise °F DB |
| 30 | 1.5 | | | | | | | 60-69 | 297-321 | 9-15 | 6-14 | 7-10 | 18-23 |
| | 2.3 | | | | | | | 63-72 | 301-325 | 9-15 | 6-14 | 5-8 | 19-23 |
| | 3.0 | | | | | | | 67-76 | 305-329 | 9-15 | 6-14 | 4-6 | 21-24 |
| 50 | 1.5 | 128-130 | 227-249 | 10-14 | 12-20 | 21-23 | 21-26 | 88-98 | 329-360 | 8-14 | 5-17 | 10-13 | 26-28 |
| | 2.3 | 128-130 | 213-234 | 11-17 | 10-18 | 15-17 | 21-26 | 93-103 | 334-365 | 8-14 | 5-17 | 7-11 | 27-30 |
| | 3.0 | 124-131 | 199-219 | 12-24 | 8-16 | 9-11 | 21-26 | 97-108 | 339-371 | 8-14 | 5-17 | 5-8 | 27-31 |
| 70 | 1.5 | 131-136 | 311-334 | 7-12 | 11-20 | 20-22 | 20-25 | 117-129 | 359-394 | 9-14 | 7-18 | 13-19 | 31-34 |
| | 2.3 | 130-135 | 297-323 | 8-11 | 10-16 | 14-17 | 20-25 | 126-136 | 369-409 | 9-14 | 7-18 | 10-15 | 32-36 |
| | 3.0 | 130-138 | 283-318 | 11-14 | 7-13 | 9-12 | 20-25 | 133-145 | 378-425 | 9-14 | 7-18 | 7-10 | 34-37 |
| 90 | 1.5 | 134-140 | 388-428 | 7-10 | 10-15 | 18-21 | 20-25 | 158-169 | 397-441 | 11-17 | 3-17 | 17-20 | 37-41 |
| | 2.3 | 133-139 | 370-406 | 8-10 | 9-13 | 13-17 | 20-25 | 167-179 | 407-452 | 11-17 | 3-17 | 13-16 | 38-42 |
| | 3.0 | 131-138 | 353-383 | 8-10 | 7-12 | 9-12 | 20-25 | 176-190 | 418-492 | 11-17 | 3-17 | 9-11 | 39-42 |
| 110 | 1.5 | 139-152 | 485-520 | 5-10 | 9-19 | 18-20 | 19-24 | | | | | | |
| | 2.3 | 138-146 | 469-497 | 6-10 | 7-17 | 13-16 | 19-24 | | | | | | |
| | 3.0 | 137-144 | 449-475 | 7-10 | 6-14 | 9-12 | 19-24 | | | | | | |

*Based on Nominal 400 cfm per ton airflow and 70°F EAT htg and 80/67°F EAT cooling

**Cooling air and water numbers can vary greatly with changes in humidity

Subcooling is based upon the head pressure at compressor service port

Table 14: Water Temperature Change Through Heat Exchanger

| Water Flow, gpm [l/m] | Rise, Cooling °F, [°C] | Drop, Heating °F, [°C] |
|--|------------------------|------------------------|
| For Closed Loop: Ground Source or Closed Loop Systems at 3 gpm per ton [3.9l/m per kW] | 9-12 | 4-11 |
| For Open Loop: Ground Water Systems at 1.5 gpm per ton [2.0l/m per kW] | 18-23 | 7-20 |

Preventive Maintenance

Water Coil Maintenance

(Direct Ground Water Applications Only)

If the installation is performed in an area with a known high mineral content (125 P.P.M. or greater) in the water, it is best to establish with the owner a periodic maintenance schedule so the coil can be checked regularly. Consult the well water applications section of this manual for a more detailed water coil material selection. Should periodic coil cleaning be necessary, use standard coil cleaning procedures which are compatible with either the heat exchanger material or copper water lines. Generally, the more water flowing through the unit the less chance for scaling therefore 1.5 gpm per ton [2.0 l/m per kW] is recommended as a minimum flow.

Water Coil Maintenance

(All Other Water Loop Applications)

Generally water coil maintenance is not needed however, if the installation is located in a system with a known high dirt or debris content, it is best to establish with the owner a periodic maintenance schedule so the coil can be checked regularly. These dirty installations are a result of the deterioration of iron or galvanized piping or components in the system or open cooling towers requiring heavy chemical treatment and mineral buildup through water use. Should periodic coil cleaning be necessary, use standard coil cleaning procedures which are compatible with both the heat exchanger material and copper water lines. Generally, the more water flowing through the unit, the less chance for scaling, however flow rates over 3 gpm per ton can produce water (or debris) velocities that can erode the heat exchanger wall and ultimately produce leaks.

Filters

Filters must be clean to obtain maximum performance. They should be inspected every month under normal operating conditions and be replaced when necessary. Units should never be operated without a filter.

Washable high efficiency electrostatic filters, when dirty, can exhibit a very high pressure drop for the fan motor and reduce air flow resulting in poor performance. It is especially important to provide consistent washing of these filters (in opposite direction of the normal air flow) once per month using a high pressure wash similar to that found at self-serve car washes.

Condensate Drain

In areas where airborne bacteria produce a slime in the drain pan, it may be necessary to treat chemically with an algicide every three months or so to minimize the problem. The condensate pan may also need to be cleaned periodically to assure indoor air quality. The condensate drain can pick up lint and dirt, especially with dirty filters. Inspect the drain twice a year to avoid the possibility of overflow.

Compressor

Conduct annual amperage checks to ensure amp draw is no more than 10% greater than that indicated by serial plate data.

Fan Motors

All units have lubricated fan motors. Inspection should be performed for proper tension and excessive wear of drive belts every three months.

Air Coil

The air coil must be cleaned to obtain maximum performance. Check once a year under normal operating conditions and, if dirty, brush or vacuum clean. Care must be taken not to damage the aluminum fins while cleaning.

CAUTION: Fin edges are sharp.

Cabinet

Do not allow water to stay in contact with the cabinet for long periods of time to prevent corrosion of the cabinet sheet metal. Generally vertical cabinets are set up from the floor a few inches for prevention. The cabinet can be cleaned using a mild detergent.

Refrigerant System

To maintain sealed circuit integrity, do not install service gauges unless unit operation appears abnormal. Reference the operating chart for pressure and temperatures. Verify that air and water flow rates and temperatures are at proper levels before servicing the refrigerant circuit.



WARNING!



WARNING! To avoid the release of refrigerant into the atmosphere, the refrigerant circuit of this unit must be serviced only by technicians who meet local, state, and federal proficiency requirements.

Functional Troubleshooting

| Fault | Htg | Clg | Possible Cause | Solution | | |
|--|--|--------------------------------|--|---|--|--|
| Main power problems | X | X | Green Status LED Off | Check line voltage circuit breaker and disconnect. | | |
| | | | | Check for line voltage between L1 and L2 on the contactor. | | |
| | | | | Check for 24VAC between R and C on CXM2/DXM2.5 | | |
| | | | | Check primary/secondary voltage on transformer. | | |
| HP Fault Code 2 High Pressure | | X | Reduced or no water flow in cooling | Check pump operation or valve operation/setting. Check water flow adjust to proper flow rate. | | |
| | | | Water Temperature out of range in cooling | Bring water temp within design parameters. | | |
| | X | | Reduced or no airflow in heating | Check for dirty air filter and clean or replace. Check fan motor operation and airflow restrictions. Dirty Air Coil - construction dust etc. Too high of external static. Check static vs blower table. | | |
| | | | | X | Air temperature out of range in heating | Bring return air temp within design parameters. |
| | | | | X X | Overcharged with refrigerant | Check superheat/subcooling vs typical operating condition table. |
| | X X | | Bad HP Switch | Check switch continuity and operation. Replace. | | |
| | LP/LOC Fault Code 3 Low Pressure / Loss of Charge | X | X | Insufficient charge | Check for refrigerant leaks | |
| Compressor pump down at start-up | | | | Check charge and start-up water flow. | | |
| LT1 Fault Code 4 Water coil low temperature limit | X | | Reduced or no water flow in heating | Check pump operation or water valve operation/setting. Plugged strainer or filter. Clean or replace. Check water flow adjust to proper flow rate. | | |
| | | | X | Inadequate antifreeze level | Check antifreeze density with hydrometer. | |
| | | | X | Improper temperature limit setting (30°F vs 10°F [-1°C vs -2°C]) | Clip JW3 jumper for antifreeze (10°F [-12°C]) use. | |
| | X | Water Temperature out of range | Bring water temp within design parameters. | | | |
| | X X | | Bad thermistor | Check temp and impedance correlation per chart | | |
| LT2 Fault Code 5 Air coil low temperature limit | X | X | Reduced or no airflow in cooling | Check for dirty air filter and clean or replace. Check fan motor operation and airflow restrictions. Too high of external static? Check static vs blower table. | | |
| | | | X | Air Temperature out of range | Too much cold vent air? Bring entering air temp within design parameters. | |
| | X | | Improper temperature limit setting (30°F vs 10°F [-1°C vs -12°C]) | Normal airside applications will require 30°F [-1°C] only. | | |
| | X X | | Bad thermistor | Check temp and impedance correlation per chart. | | |
| Condensate Fault Code 6 | X | X | Blocked drain | Check for blockage and clean drain. | | |
| | | | X | Improper trap | Check trap dimensions and location ahead of vent. Check for piping slope away from unit. | |
| | X | | Poor drainage | Check slope of unit toward outlet. Poor venting? Check vent location. | | |
| | | | X | Moisture on sensor | Check for moisture shorting to air coil. | |
| | X | X | Plugged air filter | Replace air filter. | | |
| | X | X | Restricted Return Airflow | Find and eliminate restriction. Increase return duct and/or grille size. | | |
| Over/Under Voltage Code 7 (Auto resetting) | X | X | Under Voltage | Check power supply and 24VAC voltage before and during operation. Check power supply wire size. Check compressor starting. Need hard start kit? Check 24VAC and unit transformer. Tap for correct power supply voltage. | | |
| | | | X | Over Voltage | Check power supply voltage and 24VAC before and during operation. Check 24VAC and unit transformer. Tap for correct power supply voltage. | |
| Unit Performance Sentinel Code 8 | X | | Heating mode LT2>125°F [52°C] Cooling Mode LT1>125°F [52°C] OR LT2< 40°F [4°C]) | Check for poor airflow or overcharged unit. | | |
| Swapped Thermistor Code 9 | X | X | LT1 and LT2 swapped | Reverse position of thermistors | | |
| No Fault Code Shown | X | X | No compressor operation | See "Only Fan Operates". | | |
| | X | X | Compressor overload | Check and replace if necessary. | | |
| | X | X | Control board | Reset power and check operation. | | |
| Unit Short Cycles | X | X | Dirty air filter | Check and clean air filter. | | |
| | X | X | Unit in "test mode" | Reset power or wait 20 minutes for auto exit. | | |
| | X | X | Unit selection | Unit may be oversized for space. Check sizing for actual load of space. | | |
| | X | X | Compressor overload | Check and replace if necessary | | |
| Only Fan Runs | X | X | Thermostat position | Ensure thermostat set for heating or cooling operation. | | |
| | X | X | Unit locked out | Check for lockout codes. Reset power. | | |
| | X | X | Compressor Overload | Check compressor overload. Replace if necessary. | | |
| Only Compressor Runs | X | X | Thermostat wiring | Check thermostat wiring at heat pump. Jumper Y and R for compressor operation in test mode. | | |
| | X | X | Thermostat wiring | Check G wiring at heat pump. Jumper G and R for fan operation | | |
| | X | X | Fan motor relay | Jumper G and R for fan operation. Check for Line voltage across BR contacts. | | |
| | X | X | Fan motor | Check fan power enable relay operation (if present). Check for line voltage at motor. Check capacitor. | | |
| | X | X | Thermostat wiring | Check thermostat wiring at heat pump. Jumper Y and R for compressor operation in test mode | | |
| Unit Doesn't Operate in Cooling | X | | Reversing valve | Set for cooling demand and check 24VAC on RV coil and at CXM2/DXM2.5 board. If RV is stuck, run high pressure up by reducing water flow and while operating engage and disengage RV coil voltage to push valve. | | |
| | | | X | Thermostat setup | Check for 'O' RV setup not 'B'. | |
| | X | | Thermostat wiring | Check O wiring at heat pump. Jumper O and R for RV coil 'click'. | | |
| | X | | Thermostat wiring | Put thermostat in cooling mode. Check 24 VAC on O (check between C and O); check for 24 VAC on W (check between W and C). There should be voltage on O, but not on W. If voltage is present on W, thermostat may be bad or wired incorrectly. | | |

Performance Troubleshooting

| Symptom | Htg | Clg | Possible Cause | Solution |
|---|---|---------------------------------|--|--|
| Insufficient capacity/ Not cooling or heating | X | X | Dirty filter | Replace or clean. |
| | X | | Reduced or no airflow in heating | Check for dirty air filter and clean or replace. |
| | | | | Check fan motor operation and airflow restrictions. |
| | | | | Too high of external static? Check static vs blower table. |
| | | X | Reduced or no airflow in cooling | Check for dirty air filter and clean or replace. |
| | | | | Check fan motor operation and airflow restrictions. |
| | | | | Too high of external static? Check static vs blower table. |
| | X | X | Leaky duct work | Check supply and return air temperatures at the unit and at distant duct registers if significantly different, duct leaks are present. |
| | X | X | Low refrigerant charge | Check superheat and subcooling per chart. |
| | X | X | Restricted metering device | Check superheat and subcooling per chart. Replace. |
| | | X | Defective reversing valve | Perform RV touch test. |
| X | X | Thermostat improperly located | Check location and for air drafts behind stat. | |
| X | X | Unit undersized | Recheck loads & sizing. Check sensible clg. load and heat pump capacity. | |
| X | X | Scaling in water heat exchanger | Perform scaling check and clean if necessary. | |
| X | X | Inlet water too hot or too cold | Check load, loop sizing, loop backfill, ground moisture. | |
| High Head Pressure | X | | Reduced or no airflow in heating | Check for dirty air filter and clean or replace. |
| | | | | Check fan motor operation and air flow restrictions. |
| | | | | Too high of external static? Check static vs blower table. |
| | | X | Reduced or no water flow in cooling | Check pump operation or valve operation/setting. |
| | Check water flow. Adjust to proper flow rate. | | | |
| | | X | Inlet water too hot | Check load, loop sizing, loop backfill, ground moisture. |
| | X | | Air temperature out of range in heating | Bring return air temperature within design parameters. |
| | | X | Scaling in water heat exchanger | Perform scaling check and clean if necessary. |
| X | X | Unit overcharged | Check superheat and subcooling. Re-weigh in charge. | |
| X | X | Non-condensables in system | Vacuum system and re-weigh in charge. | |
| X | X | Restricted metering device | Check superheat and subcooling per chart. Replace. | |
| Low Suction Pressure | X | | Reduced water flow in heating | Check pump operation or water valve operation/setting. |
| | | | | Plugged strainer or filter? Clean or replace. |
| | | | | Check water flow. Adjust to proper flow rate. |
| | X | | Water temperature out of range | Bring water temperature within design parameters. |
| | | X | Reduced airflow in cooling | Check for dirty air filter and clean or replace. |
| | | | | Check fan motor operation and air flow restrictions. |
| | | | Too high of external static? Check static vs blower table. | |
| | X | Air temperature out of range | Too much cold vent air? Bring entering air temperature within design parameters. | |
| X | X | Insufficient charge | Check for refrigerant leaks. | |
| Low Discharge Air Temperature in Heating | X | | Too high of airflow | Check fan motor speed selection and airflow chart. |
| | X | | Poor performance | See 'Insufficient Capacity'. |
| High humidity | | X | Too high of airflow | Check fan motor speed selection and airflow chart. |
| | | X | Unit oversized | Recheck loads & sizing. Check sensible cooling load and heat pump capacity. |

Troubleshooting Form

Customer: _____ Loop Type: _____ Startup Date: _____
 Model #: _____ Serial #: _____ Antifreeze Type & %: _____
 Complaint: _____

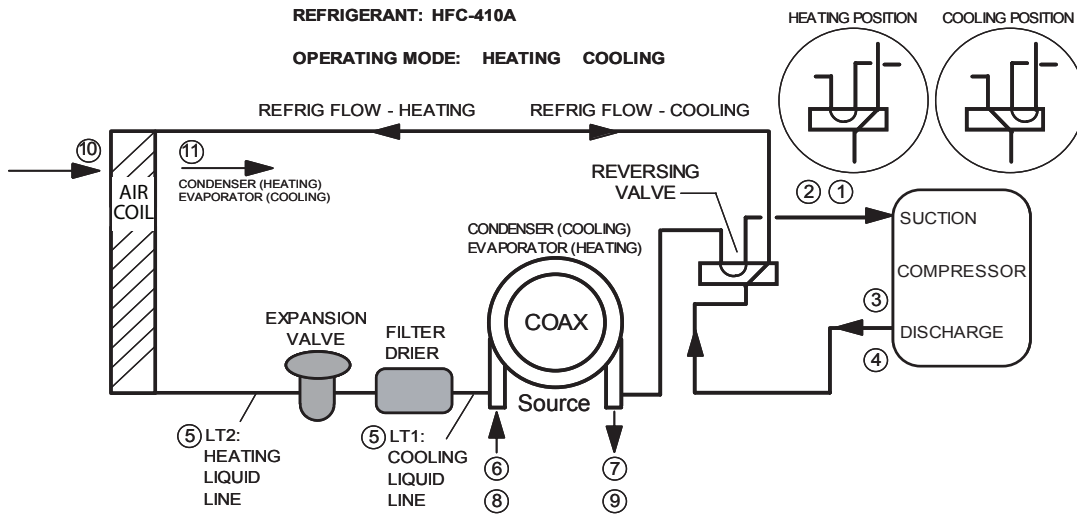

| Description | Heating | Cooling | Notes |
|-------------------------|---------|---------|--------------|
| Voltage | | | |
| Compressor Amps | | | |
| 1 Suction Temp | | | |
| 2 Suction Press | | | |
| 2a Saturation Temp | | | |
| 2b Superheat | | | |
| 3 Discharge Temp | | | |
| 4 Discharge Press | | | |
| 4a Saturation Temp | | | |
| 4b Subcooling | | | |
| 5 Liquid Line Temp | | | |
| 6 Source Water In Tmp | | | |
| 7 Source Water Out Tmp | | | Temp Diff. = |
| 8 Source Water In Pres | | | |
| 9 Source Water Out Pres | | | |
| 9a Press Drop | | | |
| 9b Flow Rate | | | |
| 10 Return Air Temp | | | |
| 11 Supply Air Temp | | | |

Heat of Extraction (Absorption) or Heat of Rejection: _____
 HE or HR = _____

Fluid Factor: (for Btuh)
 500 (Water); 485 (Antifreeze)

Fluid Factor: (for kW)
 4.18 (Water); 4.05 (Antifreeze)

_____ Flow Rate x _____ Temp. Diff x _____ Fluid Factor

Superheat = Suction temperature - suction saturation temp. = _____ (deg F)

Subcooling = Discharge saturation temp. - liquid line temp. = _____ (deg F)

Note: Never connect refrigerant gauges during startup procedures. Conduct water-side analysis using P/T ports to determine water flow and temperature difference. If water-side analysis shows poor performance, refrigerant troubleshooting may be required. Connect refrigerant gauges as a last resort.

What's New

**Follow All Warnings and Cautions in
This Manual Before Attempting Conversion.**

Top Discharge to Straight Discharge Convertible

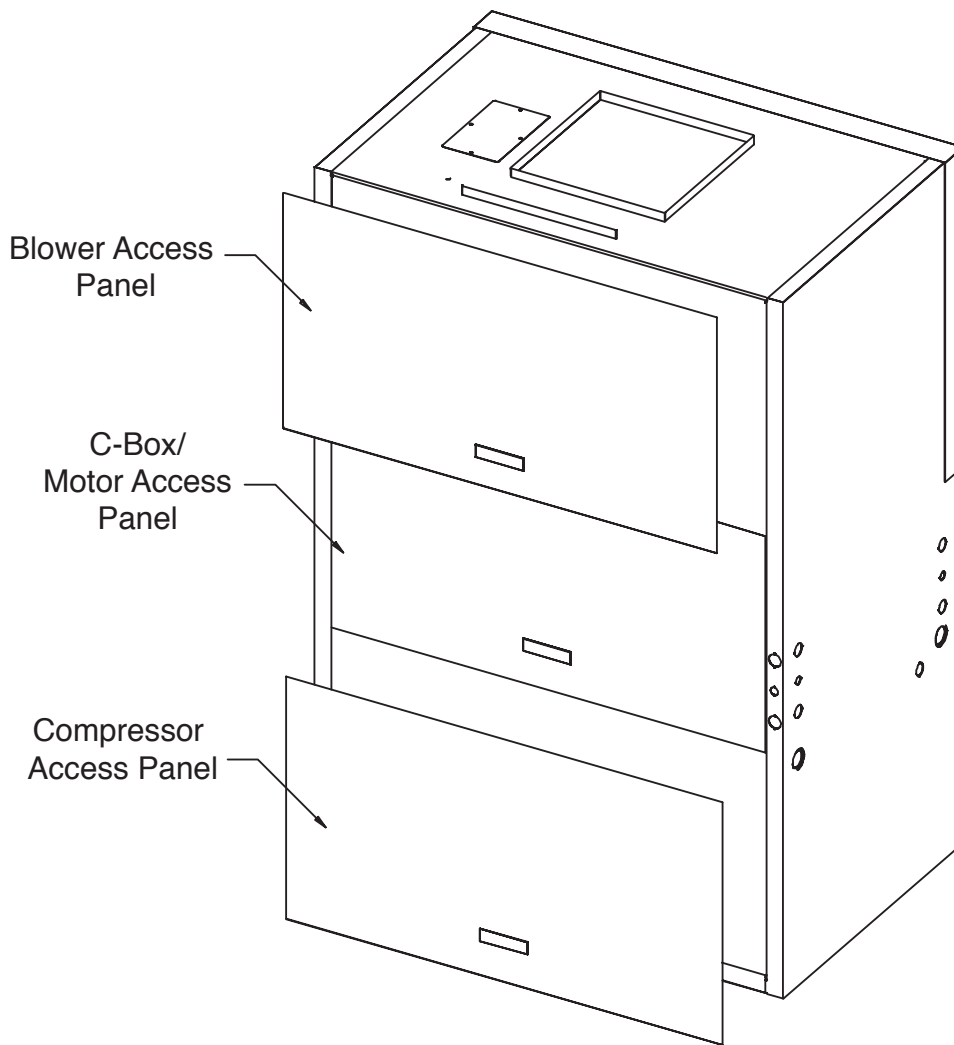

Step 1: Remove the three panels, as shown.

What's New, Cont'd.

Step 2: Remove Blockoff Air Handler as shown.
Loosen belt and remove.

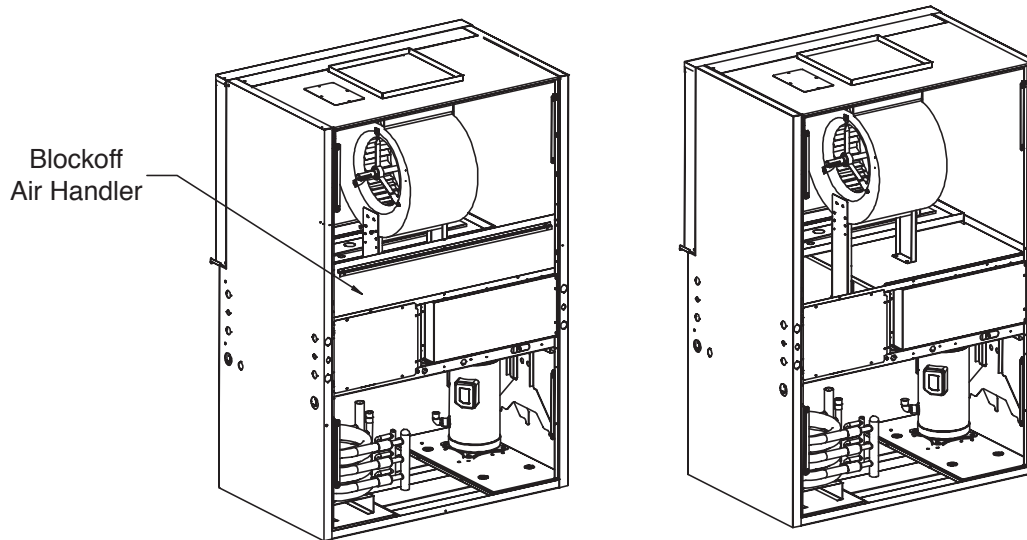

Step 3: Remove bolts (4x) off blower panel.
Remove bolts (4x) (2x ea. side) from blower sides.

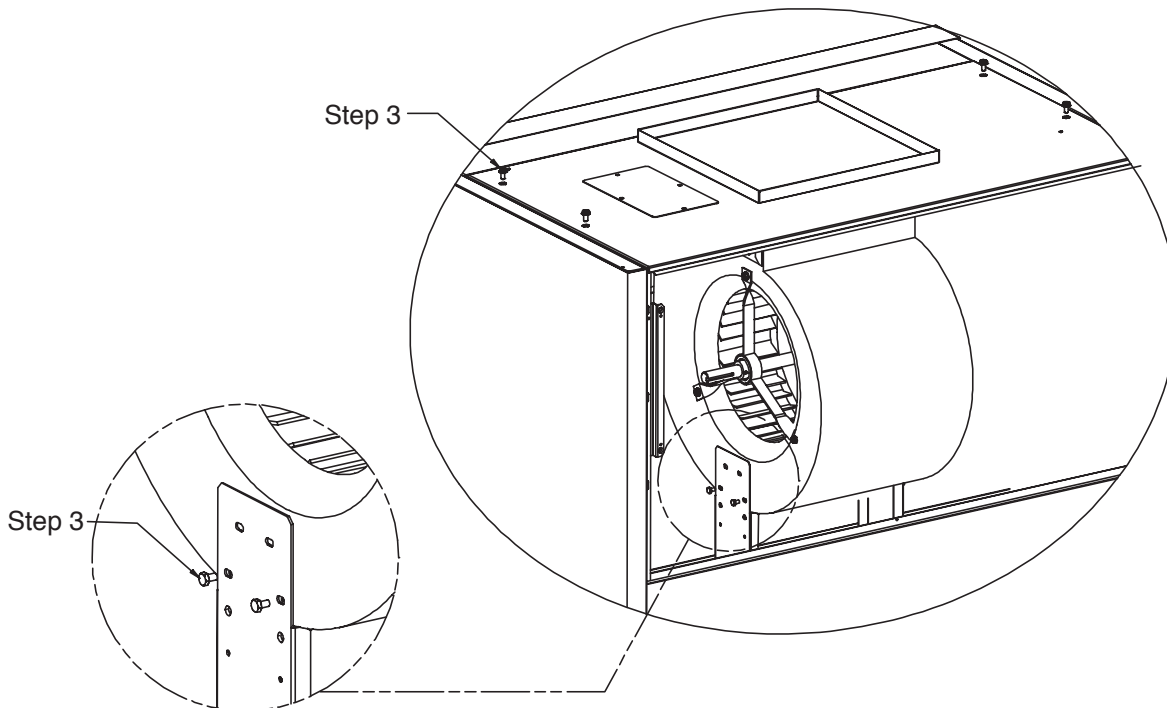

What's New, Cont'd.

Step 4: Remove bolts (4x) and take blower glides out.

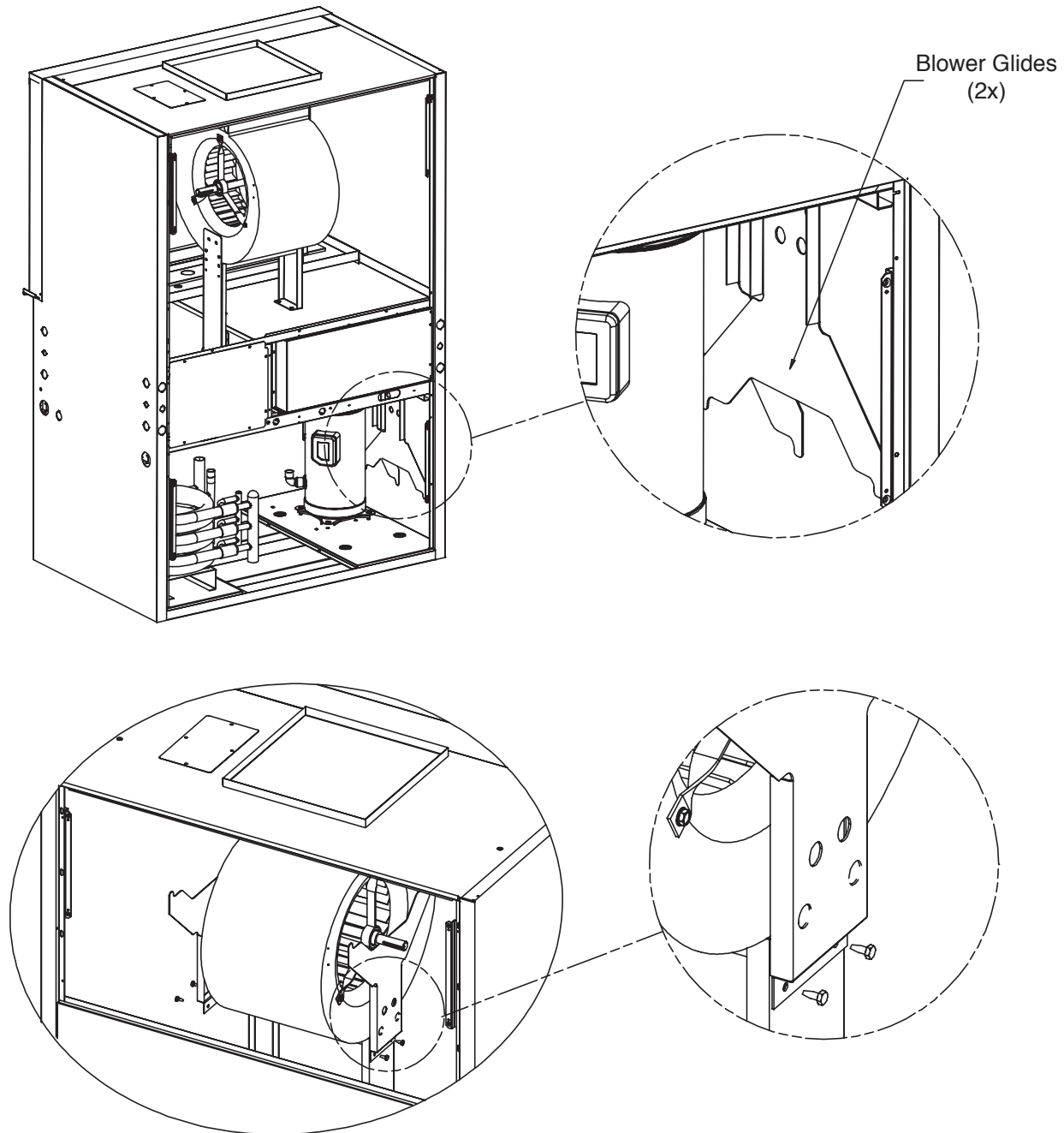

Step 5: Attach Blower Glides to Blower BTM Load Brackets as shown.
 Use bottom set of holes (.203 Dia.) on Blower BTM Load Brackets.
 Blower Shaft should be sitting right on top of the Blower Glides.

What's New, Cont'd.

Step 6: Stand in front and pull Blower ASM on to the ridge of the Blower Glides.

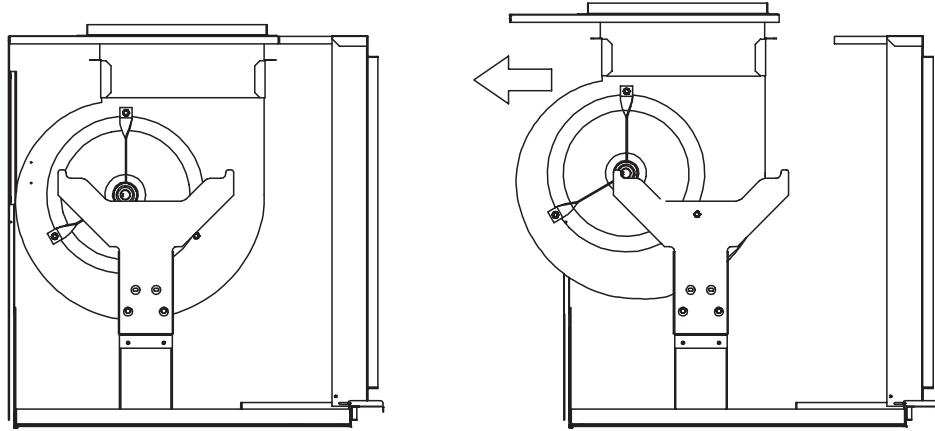

Step 7: Rotate Blower ASM using Blower Glides as a guiding track.

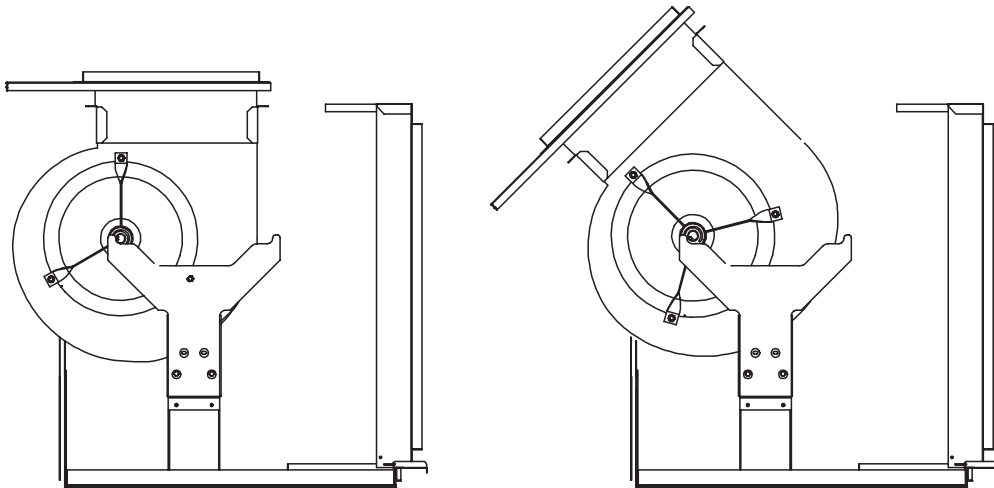

Step 8: When the Blower ASM is parallel to the floor, push the Blower ASM back so that the Blower Panel is flush with the unit.

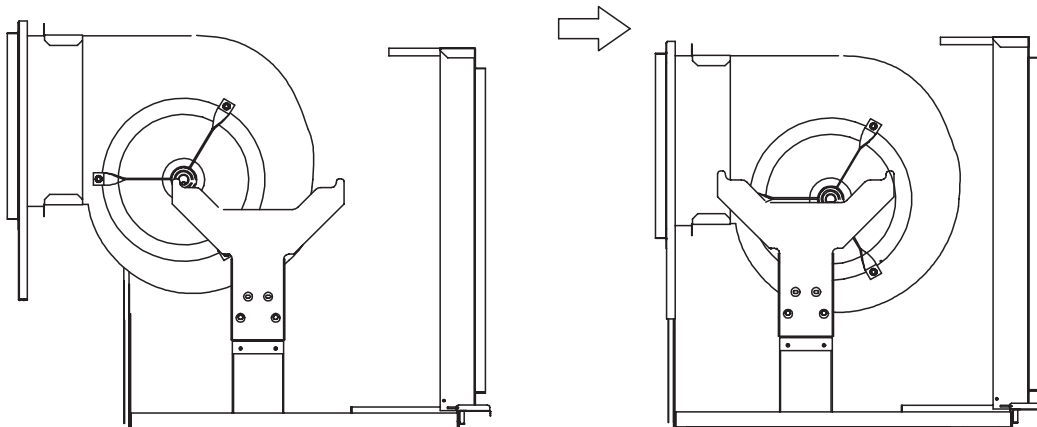

What's New, Cont'd.

Step 9: Attach Blower ASM with bolts (4x) as shown.

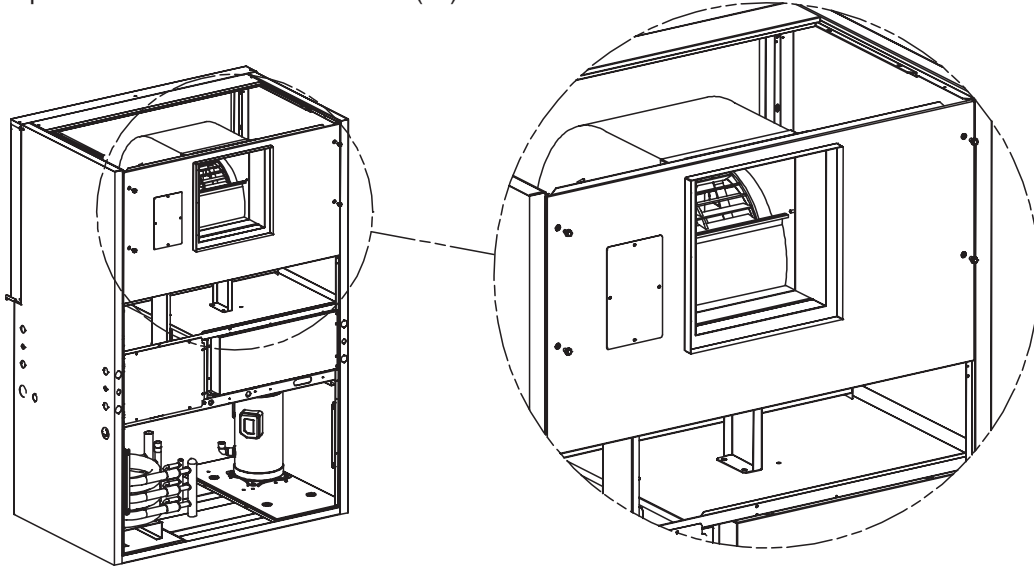

Step 10: Remove Bower Glides (2x) and re-attach back in compressor section.

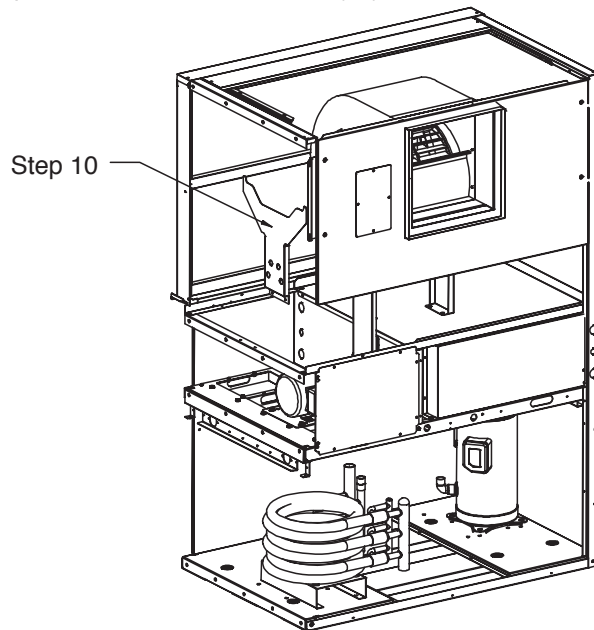

What's New, Cont'd.

Important!

Step 11: Re-bolt Blower ASM to Blower BTM load brackets
(4) 1/4 -20 UNC bolts, (2x) each side
Re-attach belt and tighten.

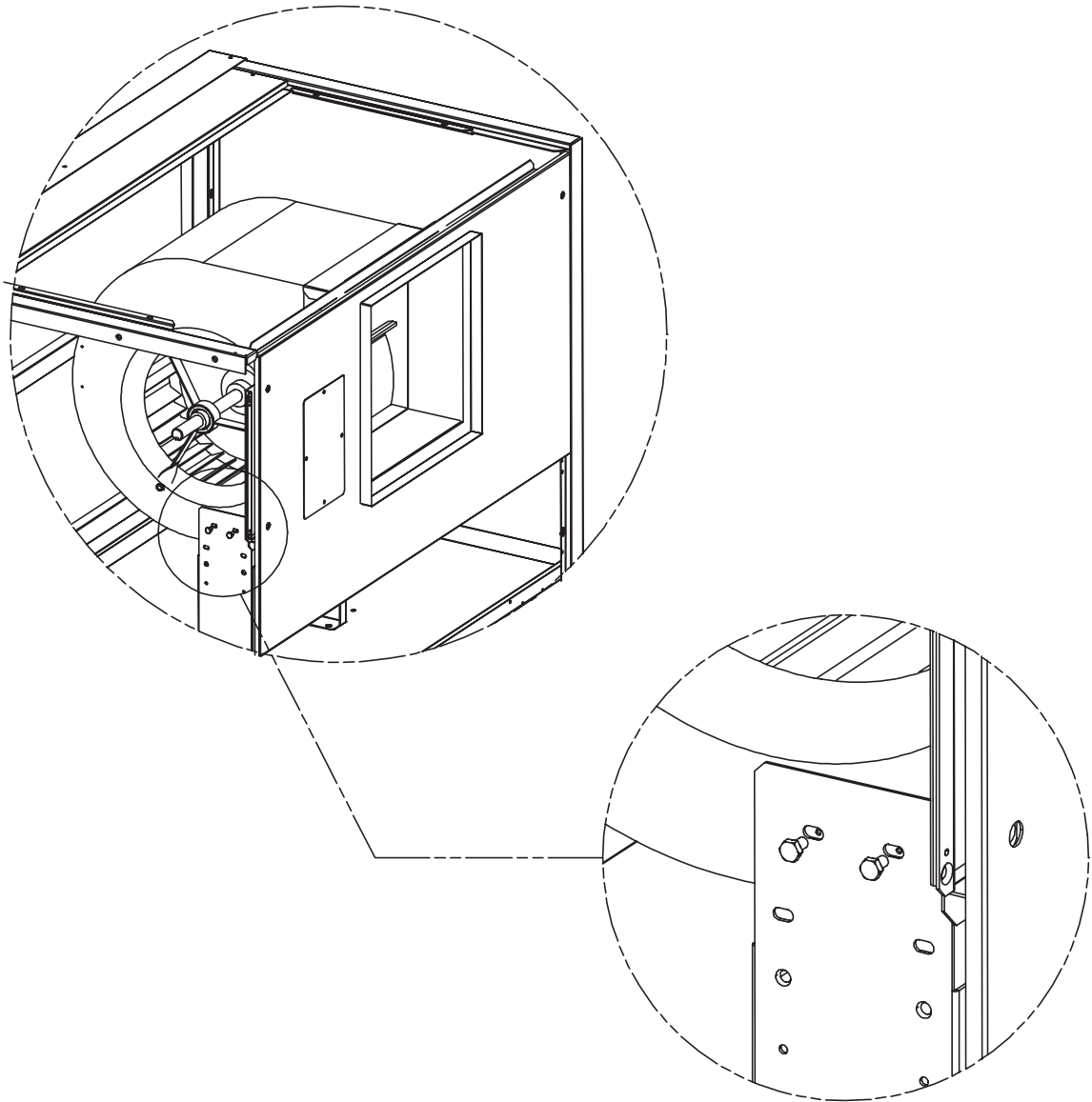

What's New, Cont'd.

Step 12: Re-attach blockoff air handler as shown.

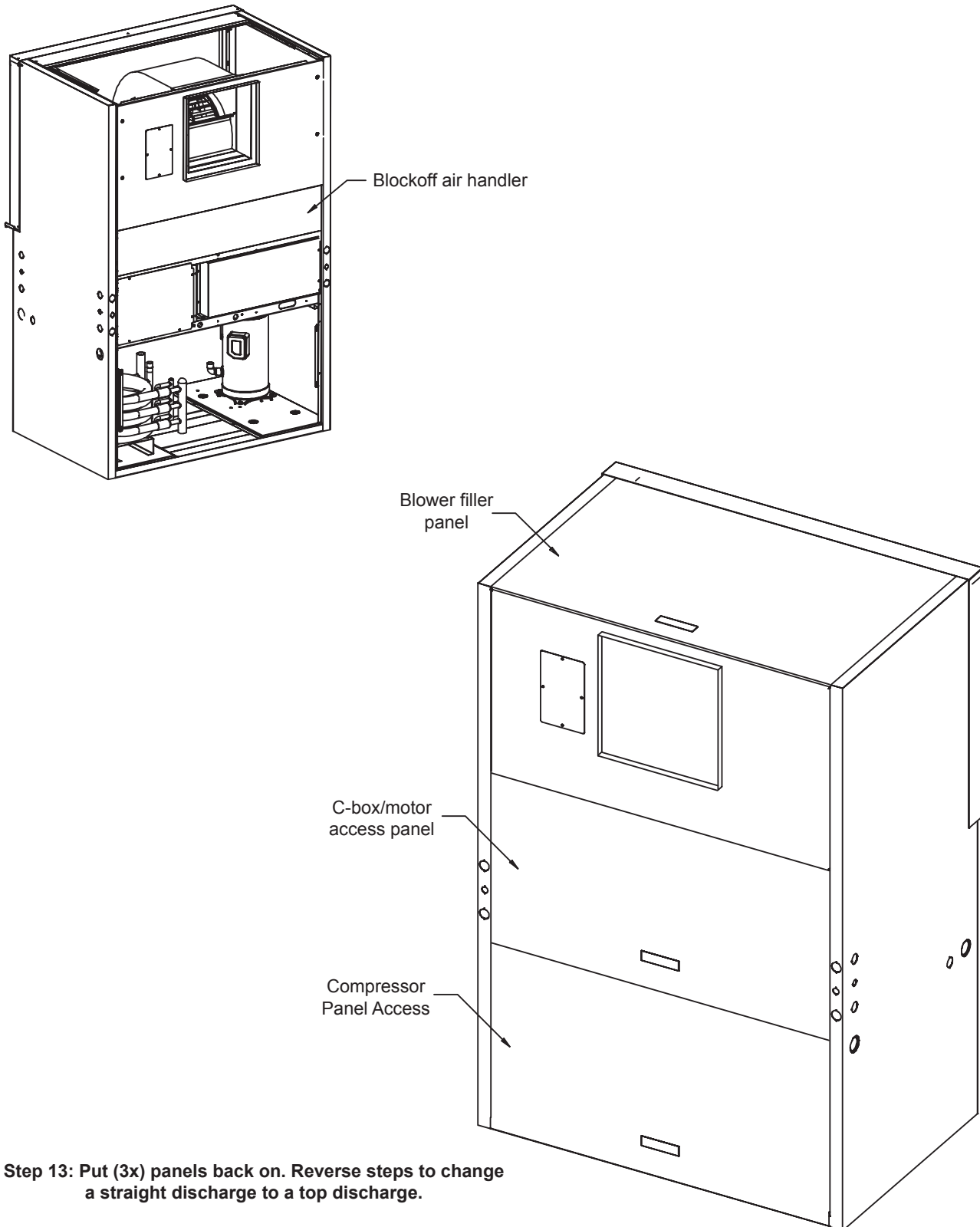

Step 13: Put (3x) panels back on. Reverse steps to change a straight discharge to a top discharge.

What's New, Cont'd.

Front Control Box/ Motor Access to Back Access Convertible

Step 1: Remove the three panels as shown.

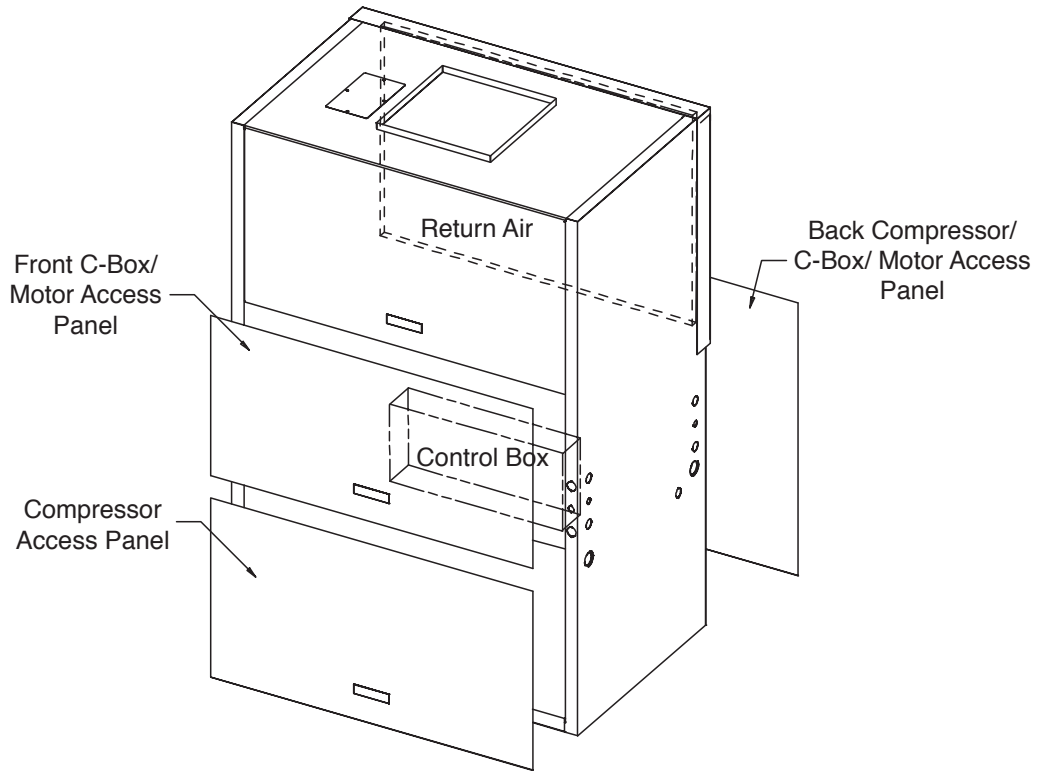

Step 2: Remove Motor Cover and Control Box Cover as shown.

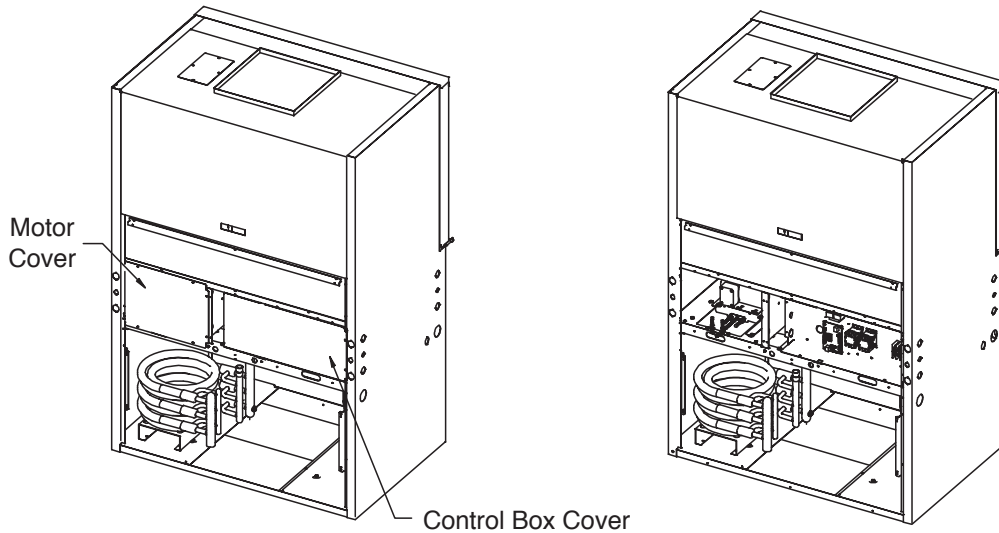

What's New, Cont'd.

Step 3: Remove screws from Control Box (Qty 4x) and A) flip down, B) slide across and C) flip up as shown using the guide rails inside as a guide. Re-attach control box with screws.

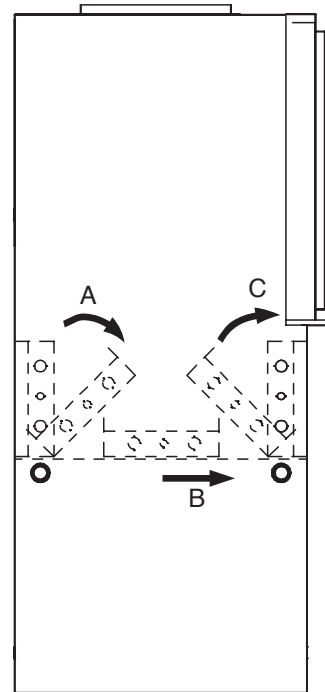
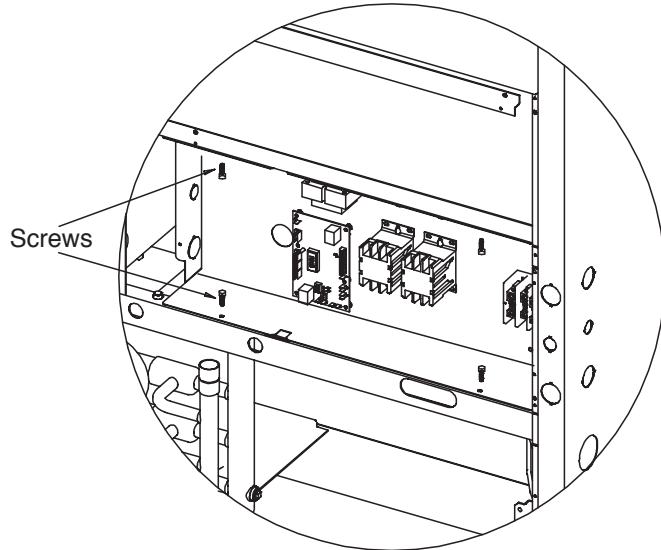

Right Side View

Step 4: Loosen Belt tension and take Belt off.
 Step 5: Remove Bolt-Belt Adjustment ASM as shown.

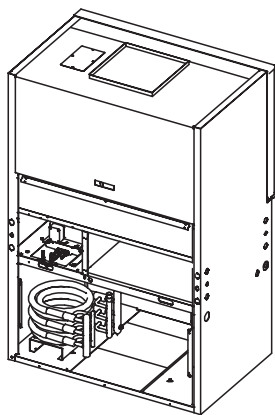

Step 5

Step 4

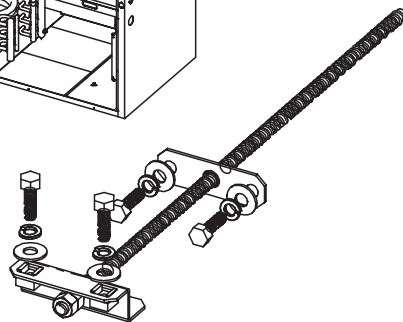
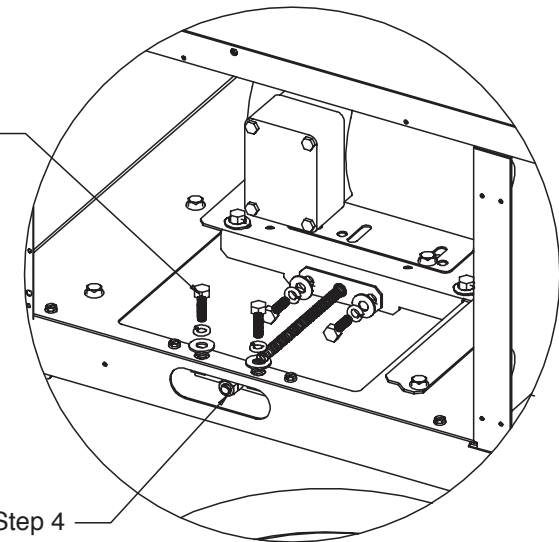

Bolt-Belt Adjustment ASM

What's New, Cont'd.

Step 6: Move Bolt-Belt Adjustment ASM to opposite side and re-attach.

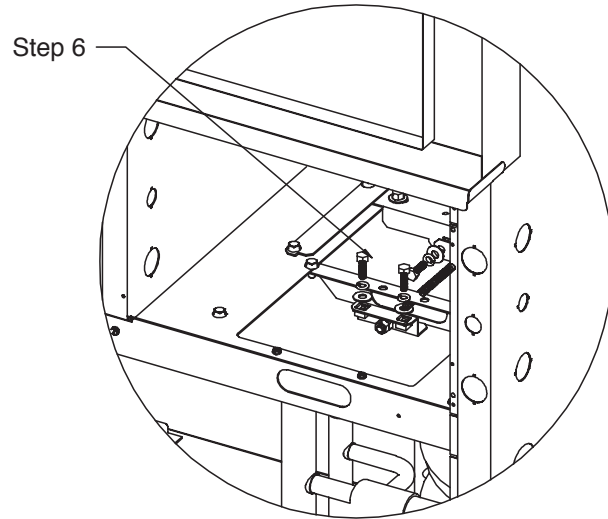
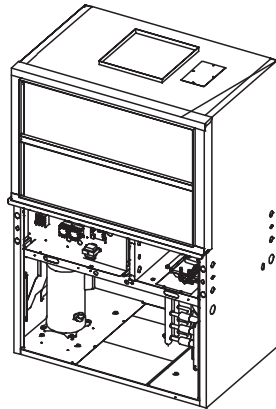

Step 7: Put Belt back on and tighten.
Put Control Box Cover and
Motor Cover on return side.

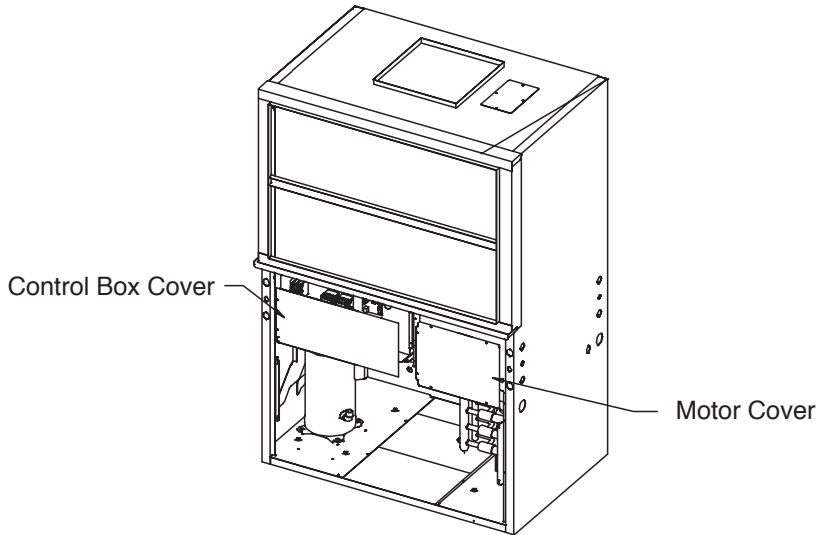

Step 8: Place panels back on unit.
Reverse steps to go from
a front return to a back return.

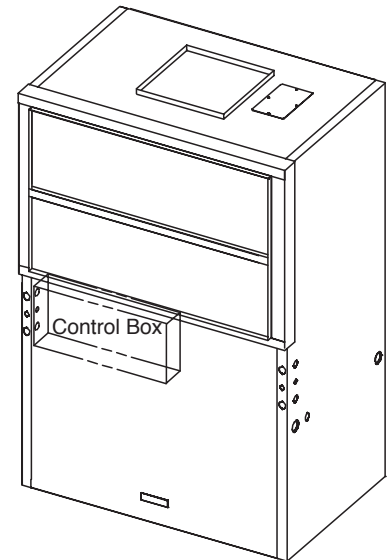

Front Return Top Discharge

What's New, Cont'd.

- Water In-Out Available on Either Side
- Hi-Low Voltage Access on Any Side
- Full Filter Frame - Bottom Access - 25, 50, 100mm
- Filters - 25 or 50mm Fiberglass and 100mm Merv 8

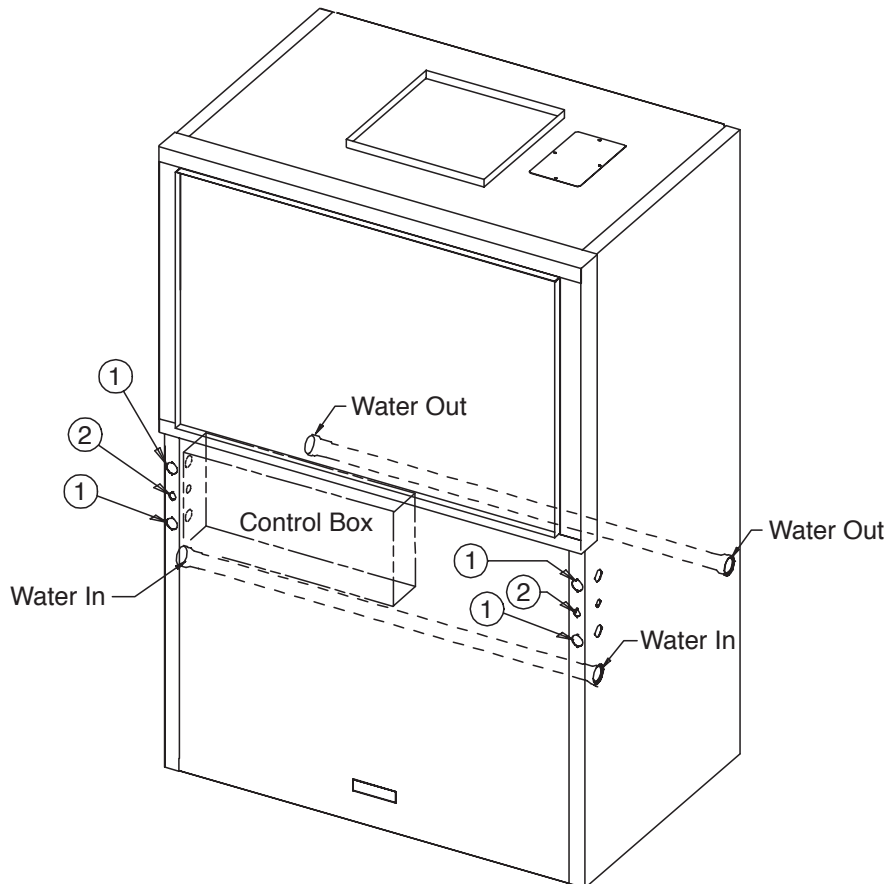

Front Return Top Discharge

1. Water inlet and outlet connections are available on either side (left or right) of the unit. MPT Plugs (Qty 2x) are shipped loose in plastic bag tied to water leg in front of the unit. Installer must plug up water inlet/outlet side that is not being connected.
2. Electrical access is available on either side (left or right) of unit and is also available (left or right) in the front of the unit.
3. 25mm Filter frame can be field converted to 50mm.

What's New, Cont'd.

Condensate Drain Can Connect to Either Side of Unit

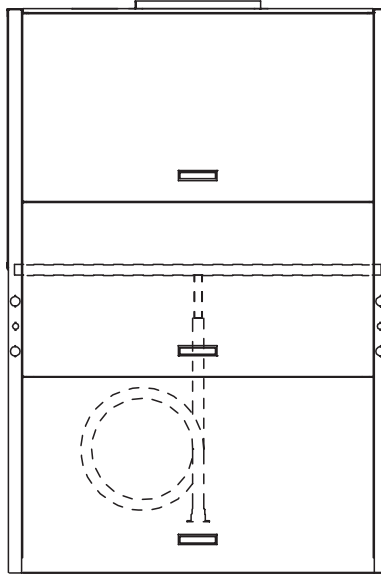

Units come with flex hose and 1" FPT condensate connection tied inside (shown above)

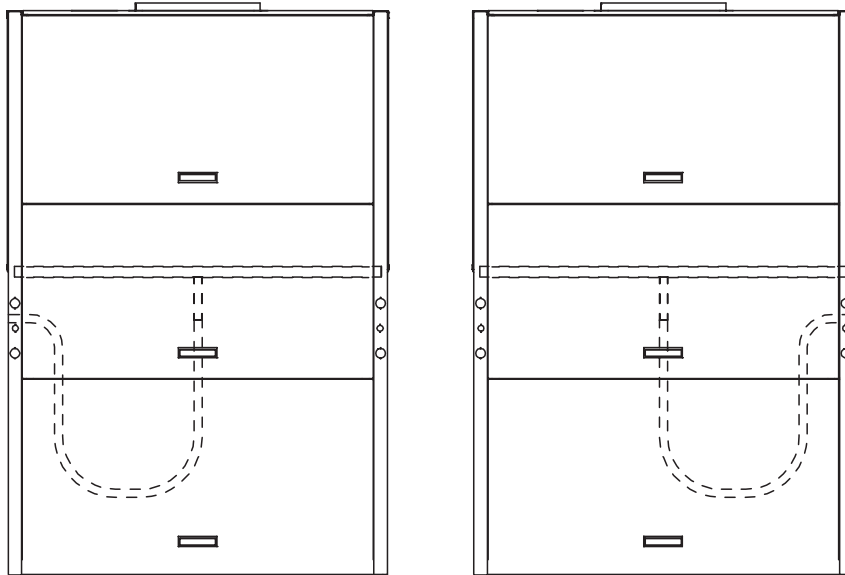

Installer will untie flex hose and make an internal trap on either the left side (shown above) or on the right side. Internally attach mounting plate with FPT fitting.

Notes:

Notes:

Revision History

| Date: | Item: | Action: |
|----------|---|---|
| 01/24/23 | All | Transitioned CXM to CXM2 and DXM to DXM2.5 unit controls |
| 06/16/14 | Pages 3, 5, 7, 8, 10, 75 | Updated filter frame description |
| 06/09/14 | Water Quality Table - page 16 & Find/Change Text "rack" to "rail" - All | Updated |
| 09/30/13 | Edit Text - Page 13 | Updated |
| 04/15/13 | EAT for ClimaDry® Option | Updated |
| 12/11/12 | Decoder-Disconnect Option | Added |
| 12/11/12 | POE Oil Warning | Added |
| 11/05/12 | Circuit Diagram with Safety Devices | Removed |
| 11/05/12 | Water Quality Table Condensate Drain Connection | Updated |
| 08/19/11 | All | Revised 460 neutral wire to only 072 and lower |
| 08/09/11 | Unit Maximum Working Water Pressure | Updated to Reflect New Safeties |
| 06/24/11 | All | Incorporated ClimaDry® II Information |
| 01/03/11 | Format - All Pages | Updated |
| 07/26/10 | Wiring Diagrams | Updated |
| 07/09/10 | Table 8 | Column Corrected from Voltage to GPM |
| 07/07/10 | Pre-Installation | Updated |
| 06/11/10 | Format - All Pages | Updated |
| 11/16/09 | 'Plugs are Shipped with Unit' Note | Note Corrected to 'Plugs are Field Supplied' |
| 11/05/09 | Warranty | Updated |
| 10/30/09 | Functional Troubleshooting Table | Updated |
| 10/09/09 | ClimaDry® II Information | Added |
| 09/14/09 | CXM/DXM Controls and CXM/DXM Safety Control Features Sections | Added |
| 07/29/09 | Unit Commissioning & Operating Conditions | Data in tables corrected |
| 06/09/09 | Unit Starting & Operating Conditions | Renamed 'Unit Commissioning & Operating Conditions' and Information updated |
| 04/06/09 | First Published | |

Due to ongoing product improvements, specifications and dimensions are subject to change and correction without notice or incurring obligations. Determining the application and suitability for use of any product is the responsibility of the installer. Additionally, the installer is responsible for verifying dimensional data on the actual product prior to beginning any installation preparations.

Incentive and rebate programs have precise requirements as to product performance and certification. All products meet applicable regulations in effect on date of manufacture; however, certifications are not necessarily granted for the life of a product. Therefore, it is the responsibility of the applicant to determine whether a specific model qualifies for these incentive/rebate programs.



1900 Wellworth Ave., Jackson, MI 49203 • Ph. 517-787-2100 • www.heatcontroller.com

* 97B0098N01 *

97B0098N01