



Installation, Operation & Maintenance

Digital Air Handler WDG Series

Air Handler for HZS Split Series

This page was intentionally left blank.

Model Nomenclature

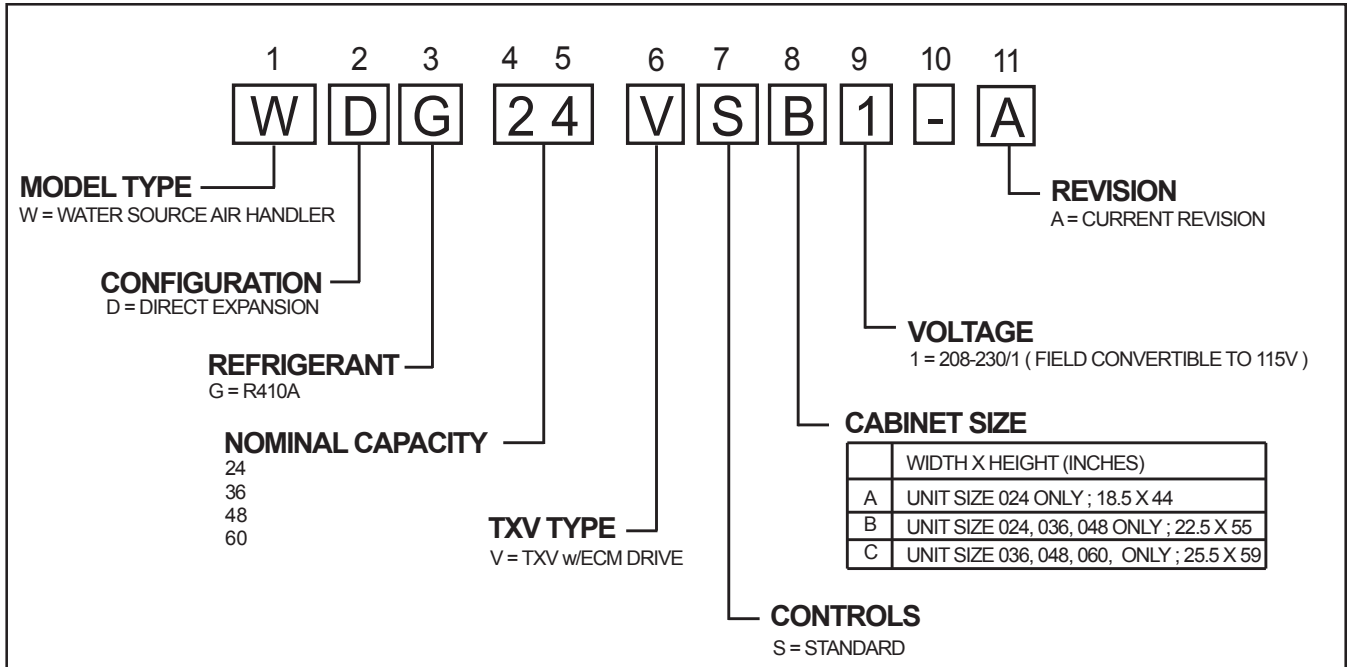

General Information

AIR HANDLER DESCRIPTION

Mars Digital Air Handlers are designed for use with indoor split units and are available for vertical upflow or downflow, and horizontal left or horizontal right airflow.

- The AXM board allows 4-wire connection with communicating split (HZS) and ATC Communicating Thermostat. Airflow and accessories can be configured on the thermostat in clear language.
- Air coils are constructed of aluminum fins bonded to internally grooved aluminum tubing.
- Air coils are tested at the factory with an extensive refrigerant leak check.
- Air coils have sweat refrigerant connections.
- Ideally suited for new installations or add on air conditioning.
- Feature two sets of 3/4" FPT Condensate drain connections for ease of connection.
- Air handlers are AHRI certified for system application with Mars indoor split units.
- Condensate drain pan is constructed of high grade, heat resistant, corrosion free thermal-set material.
- Unique drain pan design maximizes application flexibility and condensate removal.

INSPECTION

Upon receipt of the equipment, carefully check the shipment against the bill of lading. Make sure all units have been received. Inspect the packaging of each unit, and inspect each unit for damage. Insure that the carrier makes proper notation of any shortages or damage on all copies of the freight bill and completes a common carrier inspection report. Concealed damage not discovered during unloading must be reported to the carrier within 15 days of receipt of shipment. If not filed within 15 days, the freight company can deny the claim without recourse. **NOTE: It is the responsibility of the purchaser to file all necessary claims with the carrier. Notify your equipment supplier of all damage within fifteen (15) days of shipment.**

STORAGE

Equipment should be stored in its original packaging in a clean, dry area. Store units in an upright position at all times. Stack units a maximum of 3 units high.

UNIT PROTECTION

Cover units on the job site with either the original packaging or an equivalent protective covering. Cap the open ends of pipes stored on the job site. In areas where painting, plastering, and/or spraying has not been completed, all due precautions must be taken to avoid physical damage to the units and contamination by foreign material. Physical damage and contamination may prevent proper start-up and may result in costly equipment clean-up.

Examine all pipes, fittings, and valves before installing any of the system components. Remove any dirt or debris found in or on these components.

PRE-INSTALLATION

Installation, Operation, and Maintenance instructions are provided with each unit. Horizontal equipment is designed for installation above false ceiling or in a ceiling plenum. Other unit configurations are typically installed in a mechanical room. The installation site chosen should include adequate service clearance around the unit. Before unit start-up, read all manuals and become familiar with the unit and its operation. Thoroughly check the system before operation.

Prepare units for installation as follows:

1. Compare the electrical data on the unit nameplate with ordering and shipping information to verify that the correct unit has been shipped.
2. Keep the cabinet covered with the original packaging until installation is complete and all plastering, painting, etc. is finished.
3. Verify refrigerant tubing is free of kinks or dents and that it does not touch other unit components.
4. Inspect all electrical connections. Connections must be clean and tight at the terminals.

WARNING!

WARNING! These instructions are intended as an aid to qualified licensed service personnel for proper installation, adjustment and operation of this unit. Read these instructions thoroughly before attempting installation or operation. Failure to follow these instructions may result in improper installation, adjustment, service or maintenance possibly resulting in property damage, personal injury or death.

CAUTION!

CAUTION! DO NOT store or install units in corrosive environments or in locations subject to temperature or humidity extremes. Corrosive conditions and high temperature or humidity can significantly reduce performance, reliability, and service life.

CAUTION!

CAUTION! CUT HAZARD - Failure to follow this caution may result in personal injury. Sheet metal parts may have sharp edges or burrs. Use care and wear appropriate protective clothing, safety glasses and gloves when handling parts and servicing.

The installation of water source heat pump units and all associated components, parts and accessories which make up the installation shall be in accordance with the regulations of ALL authorities having jurisdiction and MUST conform to all applicable codes. It is the responsibility of the installing contractor to determine and comply with ALL applicable codes and regulations.

REPLACEMENT PARTS

Any replacement part must be the same as or an approved alternate to the original part supplied. The manufacturer will not be responsible for replacement parts not designed to physically fit or operate within the design parameters the original parts were selected for. When ordering replacement parts, it is necessary to order by part number and include the complete model number and serial number from the coil rating plate. (See parts list for unit component part numbers. Parts are available through the local distributor.)

SAFETY

Warnings, cautions and notices appear throughout this manual. Read these items carefully before attempting any installation, service, or troubleshooting of the equipment.

DANGER: Indicates an immediate hazardous situation, which if not avoided will result in death or serious injury. DANGER labels on unit access panels must be observed.

WARNING: Indicates a potentially hazardous situation, which if not avoided could result in death or serious injury.

CAUTION: Indicates a potentially hazardous situation or an unsafe practice, which if not avoided could result in minor or moderate injury or product or property damage.

NOTICE: Notification of installation, operation or maintenance information, which is important, but which is not hazard-related.

! CAUTION! !

CAUTION! It is recommended that an auxiliary secondary drain pan be installed under units containing evaporator coils that are located in any area of a structure where damage to the building or building contents may occur as a result of an overflow of the coil drain pan or a stoppage in the primary condensate drain piping.

! WARNING! !

WARNING! All refrigerant discharged from this unit must be recovered **WITHOUT EXCEPTION**. Technicians must follow industry accepted guidelines and all local, state, and federal statutes for the recovery and disposal of refrigerants. To avoid leakage of compressor oil, refrigerant lines of the compressor must be sealed after it is removed.

! CAUTION! !

CAUTION! To avoid equipment damage, **DO NOT** use these units as a source of heating or cooling during the construction process. The mechanical components and filters will quickly become clogged with construction dirt and debris, which may cause system damage.

The following warning complies with State of California law, Proposition 65.

! WARNING! !

WARNING! This product can expose you to chemicals including Carbon Black, which is known to the State of California to cause cancer and Methanol, which is known to the State of California to cause birth defects or other reproductive harm. For more information go to www.P65Warnings.ca.gov.

! WARNING! !

WARNING! The EarthPure® Application and Service Manual should be read and understood before attempting to service refrigerant circuits with HFC-410A.

! WARNING! !

WARNING! To avoid the release of refrigerant into the atmosphere, the refrigerant circuit of this unit must be serviced only by technicians who meet local, state, and federal proficiency requirements.

Unit Physical Data

Table 1: WDG Physical Data

Model	024-A	024-B	036-B	036-C	048-B	048-C	060-C
Liquid I.D. in.	3/8	3/8	3/8	3/8	3/8	3/8	3/8
Suction I.D. in.	3/4	3/4	7/8	7/8	7/8	7/8	7/8
Fan Motor Type/Speeds	ECM Variable						
Fan Motor (hp)	1/2				1		
Blower Wheel Size (Dia x W) in. [mm]	9 x 7 [229 x 178]		11 x 10 [279 x 254]				
Air Coil Dimensions (H x W) in. [mm]	14 x 17 [356 x 432]		24 x 17 [610 x 432]				24x17 [610 x 432]
Filter Standard - 1" [25mm] Thick Throwaway in. [mm]	16 x 20 [406 x 508]	20 x 20 [508 x 508]		20 x 24 [508 x 610]	20 x 20 [508 x 508]	20 x 24 [508 x 610]	
Weight - Operating lbs. [kg]	80 [36]	163 [74]	173 [78]	181 [82]	180 [82]	188 [85]	198 [90]
Weight - Packaged lbs. [kg]	96 [44]	179 [81]	198 [90]	206 [93]	218 [99]	226 [103]	236 [107]

Unit Dimensional Data

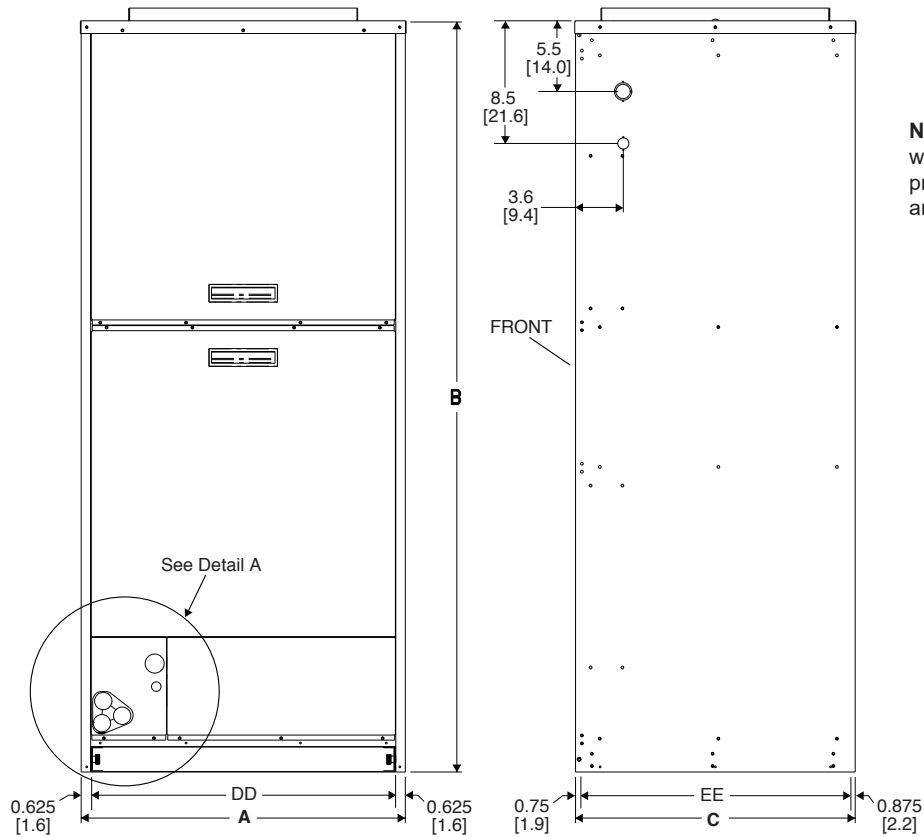
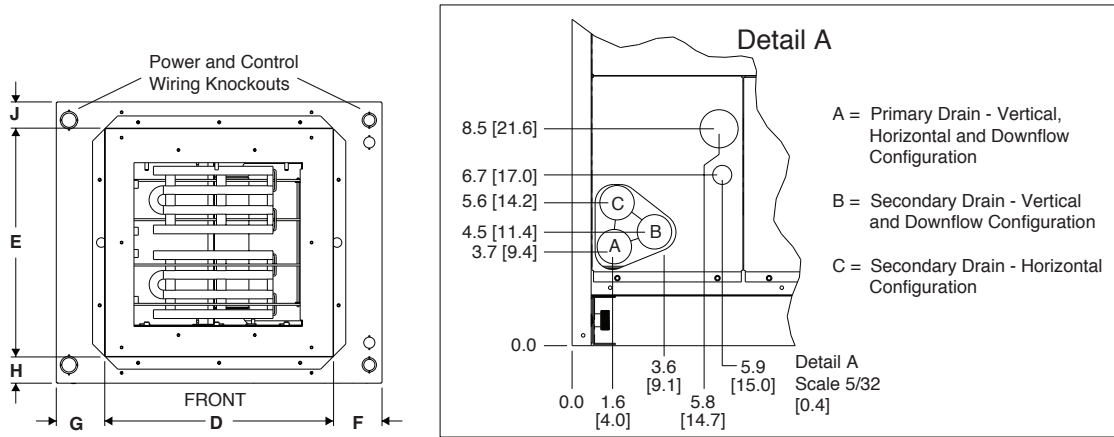

Cabinet Size	Overall Cabinet			Supply Air Opening		Return Air Opening		F	G	H	J	
	A Width	B Height	C Depth	D Width	E Depth	DD Width	EE Depth					
A - Cabinet	in.	18.5	44.0	22.0	14.0	14.0	17.3	20.4	2.3	2.3	4.1	4.1
	cm.	47.0	111.8	55.9	35.6	35.5	43.9	51.8	5.8	5.8	10.3	10.3
B - Cabinet	in.	22.0	55.0	22.0	18.0	18.0	20.8	20.4	2.1	2.1	2.1	2.1
	cm.	55.9	139.7	55.9	45.7	45.7	52.8	51.8	5.2	5.2	5.2	5.2
C - Cabinet	in.	25.5	59.0	22.0	18.0	18.0	24.3	20.4	3.8	3.8	2.1	2.1
	cm.	64.8	149.9	55.9	45.7	45.7	61.7	51.8	9.9	9.9	5.2	5.2

Installation

The WDG Air Handler(s) are designed for upflow, horizontal, and downflow applications. The coils have a dry nitrogen holding charge and are equipped with brazing stub refrigerant connections for easy installation. All models come equipped with a factory installed TXV.

THE INSTALLER SHOULD:

1. Where precise forming of refrigerant lines is required, a tubing bender is recommended for copper tubing. One should avoid sharp bends and contact of the refrigerant lines with metal surfaces.
2. Refrigerant lines should be protected where they pass through the raw edges of holes.
3. Air handler must be level or slightly pitched toward drain for proper condensate drainage.
4. Seal the openings into the cabinet to reduce risk of condensate blow off from the coil.
5. After ductwork connections are made, seal airtight and per local codes.
6. The unit is then placed with the blower side down and the coil is replaced on the coil channel supports with the drain connections at the bottom. The unit is now in downflow position with front access. Position the ECM wire harness connection at the 4 to 8 o'clock position to prevent condensation from entering motor controller.
7. If a return duct is connected to the air handler, it must be the same dimensions as the return opening.
8. After ductwork connections are made, seal airtight and per local codes.

Air Handler Installation



WARNING!

WARNING! Electric furnaces may be connected to more than one supply circuit.

CHARGING THE SYSTEM

WDG Air Handler(s) are designed to match HZS split units. For correct charging, please refer to the Compressor Section IOM.

UPFLOW INSTALLATION

1. Position unit on plenum box or other suitable foundation. Provide a minimum height for proper unrestricted airflow based on CFM requirement for each unit size.
2. If a return air duct is connected to the air handler, it must be the same dimensions as shown in the outline drawing in Figure 1.
3. Plenum box and unit should be isolated from the foundation using a suitable isolating material.
4. Openings where field wiring enters the cabinet must be completely sealed. Location of power entry is shown on the outline drawing.
5. After ductwork connections are made, seal airtight and per local codes.

DOWNFLOW INSTALLATION

1. Position unit on plenum box or other suitable foundation. Provide a minimum height for proper unrestricted airflow based on CFM requirement for each unit size.
2. If a return air duct is connected to the air handler, it must be the same dimensions as shown in the outline drawing in Figure 1.
3. Plenum box and unit should be isolated from the foundation using a suitable isolating material.
4. Openings where field wiring enters the cabinet must be completely sealed. Location of power entry is shown on the outline drawing.

HORIZONTAL RIGHT INSTALLATION

For horizontal installations where access to the factory provided air filter is limited it is recommended to remove the factory filter and use a properly sized remote filter grille/box to maintain maximum efficiency and for customer ease of filter maintenance. Unit airflow should not exceed the rated velocity of the air filter that is used.

1. To convert the unit to horizontal right, front access, slide the coil out on the coil channel supports and rotate the complete coil 180 degrees.
2. The coil is then inserted back into the cabinet on the opposite side coil channel supports. The unit is now horizontal right with front access. Rotate blower motor as needed so that wiring connections are at the 4 to 8 o'clock position. This will prevent any condensation present on the wiring from entering the motor.
3. If the unit is suspended, it must be supported from the bottom near both ends as well as the middle to prevent sagging. The service access must remain unobstructed. If the unit is supported along the length of the front and back with rails, the air handler only needs to be suspended at both ends. See Figure 2. If the unit is not suspended it must be supported as mentioned above and isolated carefully to prevent sound transmission. Vibration isolators (purchased locally) must be placed under the unit.
4. It is always recommended that an auxiliary drain pan be installed under a horizontal air handler (See Figure 2) to prevent possible damage to ceilings.
5. Isolate the auxiliary drain pan from the unit or from the structure.
6. Connect the auxiliary drain line to a separate drain line (no trap is needed in this line) and terminate according to national and local codes.
7. If a return duct is connected to the air handler, it must be the same dimensions as the return opening shown in the outline drawing on Figure 1.
8. Openings where field wiring enters the cabinet must be completely sealed.
9. After ductwork connections are made, seal airtight and per local codes.

Installation (Cont.)

HORIZONTAL LEFT INSTALLATION

For horizontal installations where access to the factory provided air filter is limited it is recommended to remove the factory filter and use a properly sized remote filter grille/box to maintain maximum efficiency and for customer ease of filter maintenance. Unit airflow should not exceed the rated velocity of the air filter that is used.

1. Unit is shipped from the factory in the upflow or horizontal left configuration. Unit conversion is not required. Rotate blower motor as needed so that wiring connections are at the 4 to 8 o'clock position. This will prevent any condensation present on the wiring from entering the motor.
2. If the unit is suspended, it must be supported from the bottom near both ends as well as the middle to prevent sagging. The service access must remain unobstructed. If the unit is supported along the length of the front and back, the air handler only needs to be suspended at both ends. See Figure 2.
3. If the unit is not suspended it must be supported as mentioned above and isolated carefully to prevent sound transmission. Vibration isolators (purchased locally) must be placed under the unit.
4. It is always recommended that an auxiliary drain pan be installed under a horizontal air handler (See Figure 2) to prevent possible damage to ceilings.
5. Isolate the auxiliary drain pan from the unit or from the structure.
6. Connect the auxiliary drain line to a separate drain line (no trap is needed in this line) and terminate according to national and local codes.
7. If a return duct is connected to the air handler, it must be the same dimensions as the return opening shown in the outline drawing on Figure 1.
8. Openings where field wiring enters the cabinet must be completely sealed. Location of power entry is shown on the outline drawing.
9. After ductwork connections are made, seal airtight and per local codes.

DUCT CONNECTIONS

The supply and return air ducts should be connected to the unit with flame retardant duct connectors.

NOTE: No sheetmetal screws may be used to attach return ductwork on the side.

NOTE: Any duct board return connection can be made to the sides of the unit using tape or mastic.

Figure 2: Mounting Installation Options

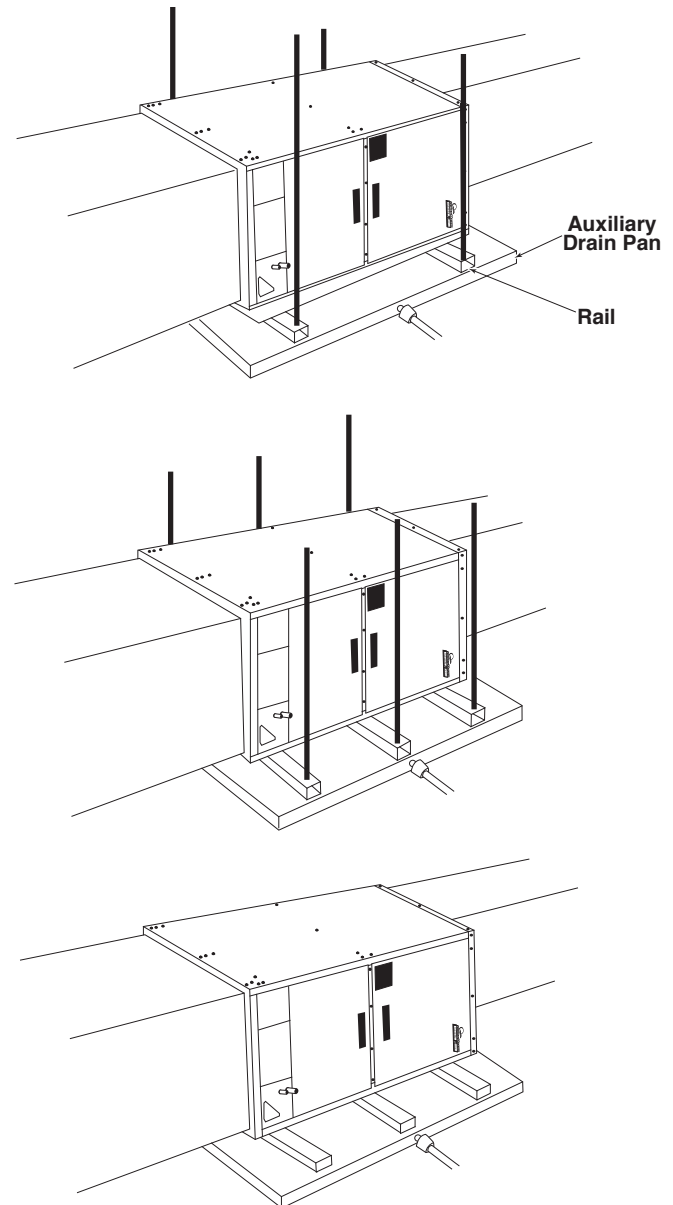
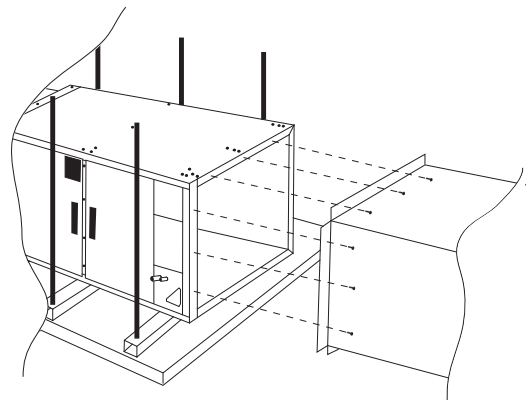

Figure 3: Flange Attachment



Installation (Cont.)

APPLICATIONS

WDG Air Handler(s) can be applied in upflow, downflow, horizontal right and horizontal left applications. For horizontal applications, installation of an auxiliary/secondary drain pan is always recommended to prevent possible damage to ceilings.

⚠ CAUTION! ⚠

CAUTION! For horizontal applications, the horizontal drain pan must be located under the indoor coil. Failure to place the pan under the coil can result in property damage.

Figure 4: Air Handler Orientation

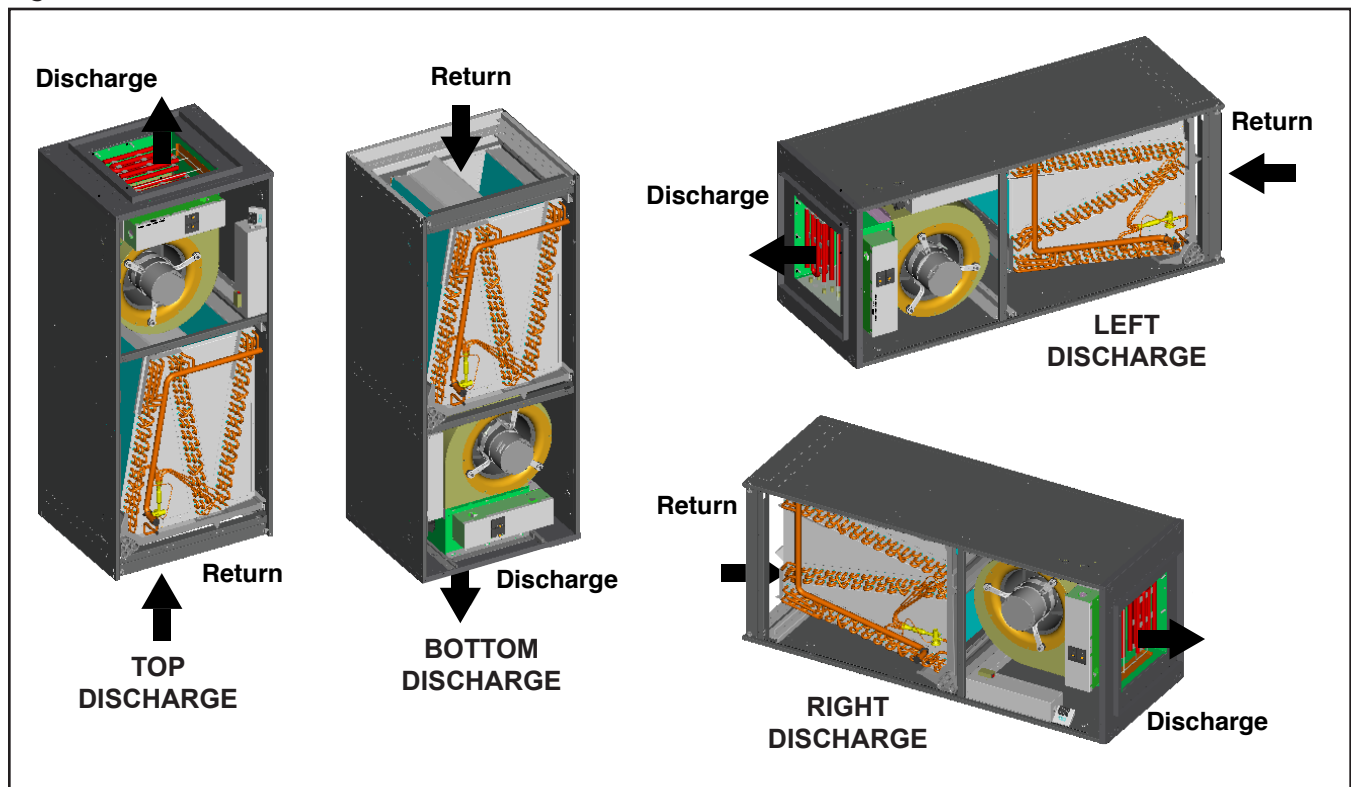

WDG 1" TO 2" FILTER RACK CONVERSION

The unit is shipped with 1" filter rack from the factory. The conversion process is assumed that the unit is in upflow configuration.

1. Place unit on a flat surface. Remove 2 knurled thumb knobs that secure the filter rack door at the bottom of the unit.
2. Remove 3 screws that secure the lower filter tracks on each side of the unit.
3. Lift and rotate the filter tracks upside down and reinstall filter tracks and screws back.
4. Replace the filter rack door and the 2 knurled thumb knobs.

Installation (Cont.)

⚠ CAUTION! ⚠

CAUTION! HFC-410A systems operate at higher pressures than R-22 systems. Be certain that service equipment (gauges, tools, etc.) is rated for HFC-410A. Some R-22 service equipment may not be acceptable.

⚠ CAUTION! ⚠

CAUTION! Installation of a factory supplied liquid line bi-directional filter drier is required. Never install a suction line filter in the liquid line.

LINE SET INSTALLATION

Figure 7 illustrates a typical installations of an air handler or cased coil matched to an indoor compressor section. Table 2 shows typical line-set diameters at various lengths. Lineset lengths should be kept to a minimum and should always be installed with care to avoid kinking. Line sets are limited to 60 feet (18 meters) in length (one way). Line sets over 60 feet void the equipment warranty. If the line set is kinked or distorted, and it cannot be formed back into its original shape, the damaged portion of the line should be replaced. A restricted line set will effect the performance of the system.

All brazing should be performed using nitrogen circulating at 2-3 psi [13.8-20.7 kPa] to prevent oxidation inside the tubing. All linesets should be insulated with a minimum of 1/2" [13mm] thick closed cell insulation. All insulation tubing should be sealed using a UV resistant paint or covering to prevent deterioration from sunlight.

See compressor section IOM for refrigerant charge information.

When passing refrigerant lines through a wall, seal opening with silicon-based caulk. Avoid direct contact with water pipes, duct work, floor joists, wall studs, floors or other structural components that could transmit compressor vibration. Do not suspend refrigerant tubing from joists with rigid straps. Do not attach line set to the wall. When necessary, use hanger straps with isolation sleeves to minimize transmission of line set vibration to the structure.

INSTALLING THE INDOOR COIL AND LINESET

Figure 5 shows the installation of the lineset and TXV bulb to a typical indoor coil. Braze the copper line set to the coil. Nitrogen should be circulated through the system at 2-3 psi [13.8-20.7 kPa] to prevent oxidation inside the refrigerant tubing. Use a low silver phos-copper braze alloy on all brazed connections.

Figure 5: Air Coil Connection

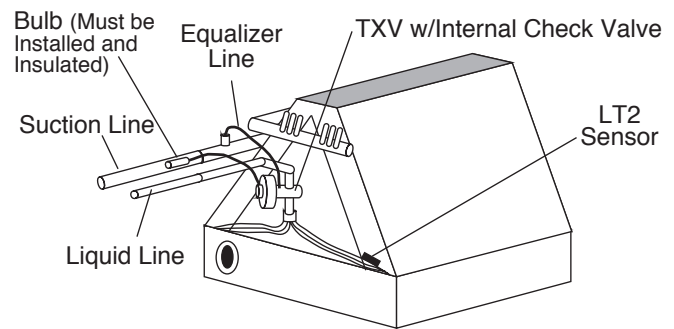

SENSING BULB

IMPORTANT: DO NOT perform any brazing with the TXV bulb attached to any line. After brazing operations have been completed, clamp the TXV bulb securely on the suction line at the 10 or 2 o'clock position with the strap provided in the parts bag. Insulate the TXV sensing bulb and suction line with the provided pressure sensitive insulation.

IMPORTANT: TXV sensing bulb should be located on a horizontal section of copper suction line, just outside of coil box. The copper sensing bulb must never be placed on any aluminum tube as this will result in galvanic corrosion and eventual failure of the aluminum tube.

IMPORTANT: Always protect TXV from heat when brazing.

AIR COIL

To obtain maximum performance of a newly manufactured air coil it should be cleaned before start-up. A 10% solution of dishwasher detergent and water is recommended for both sides of the coil. A thorough water rinse should follow.

Table 2: Line Set Diameters

Model	20 feet [6 meters]		40 feet [12 meters]		60 feet [18 meters]	
	Liquid	Suction	Liquid	Suction	Liquid	Suction
WDG/024 in.	3/8"	3/4"	3/8"	3/4"	3/8"	3/4"
WDG/036 in.	3/8"	7/8"	3/8"	7/8"	3/8"	7/8"
WDG/048 in.	3/8"	7/8"	3/8"	7/8"	3/8"	7/8"
WDG/060 in.	1/2"	7/8"	1/2"	7/8"	1/2"	7/8"

* 60 feet (18 meters) is the maximum line set length.

Installation (Cont.)

EVACUATION AND CHARGING THE UNIT

LEAK TESTING - The refrigeration line set must be pressurized and checked for leaks before evacuating and charging the unit. To pressurize the line set, attach refrigerant gauges to the service ports and add an inert gas (nitrogen or dry carbon dioxide) until pressure reaches 60-90 psig [413-620 kPa]. Never use oxygen or acetylene to pressure test. Use a good quality bubble solution to detect leaks on all connections made in the field. Check the service valve ports and stem for leaks. If a leak is found, repair it and repeat the above steps. For safety reasons do not pressurize system above 150 psig [1034 kPa]. System is now ready for evacuation and charging.

CONDENSATE DRAIN TUBING

Consult local codes or ordinances for specific requirements.

IMPORTANT: When making drain fitting connections to the drain pan, use a thin layer of Teflon paste, silicone or Teflon tape and install hand tight.

IMPORTANT: When making drain fitting connections to drain pan, do not overtighten. Overtightening fittings can split pipe connections on the drain pan.

- Install drain lines so they do not block service access to front of the unit. Minimum clearance of 24 inches (61 cm) is required for filter, coil or blower removal and service access.
- Make sure unit is level or pitched slightly toward primary drain connection so that water will drain completely from the pan (See Figure 6).
- Do not reduce drain line size less than connection size provided on condensate drain pan.
- All drain lines must be pitched downward away from the unit a minimum of 1/8" per foot (11 mm per m) of line to ensure proper drainage.
- Do not connect condensate drain line to a closed or open sewer pipe. Run condensate to an open drain or outdoors.
- The drain line should be insulated where necessary to prevent sweating and damage due to condensate forming on the outside surface of the line.
- Make provisions for disconnecting and cleaning of the primary drain line should it become necessary. Install condensate trap at each unit with the top of the trap positioned below the unit condensate drain connection as shown in Figure 6. Design the depth of the trap (water-seal) based upon the amount of ESP capability of the blower (where 2 inches [51mm] of ESP capability requires 2 inches [51mm] of trap depth). As a general rule, 1-1/2 inch [38mm] trap depth is the minimum.

- Always vent the condensate line when dirt or air can collect in the line or a long horizontal drain line is required. Also vent when large units are working against higher external static pressure than other units connected to the same condensate main since this may cause poor drainage for all units on the line. **WHEN A VENT IS INSTALLED IN THE DRAIN LINE, IT MUST BE LOCATED AFTER THE TRAP IN THE DIRECTION OF THE CONDENSATE FLOW.**
- Auxiliary drain line should be run to a place where it will be noticeable if it becomes operational. Occupant should be warned that a problem exists if water should begin running from the auxiliary drain line.
- Plug the unused drain connection with the plugs provided in the parts bag, using a thin layer of Teflon paste, silicone or Teflon tape to form a water tight seal.
- Test condensate drain pan and drain line after installation is complete. Pour water into drain pan, enough to fill drain trap and line. Check to make sure drain pan is draining completely, no leaks are found in drain line fittings, and water is draining from the termination of the primary drain line.

Figure 6: Condensate Drain Trap

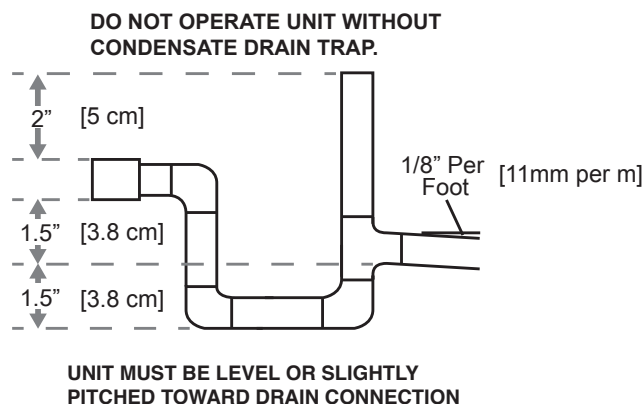

It is always recommended that an auxiliary drain pan be installed under a horizontally installed air handler.

Connect the auxiliary drain line to a separate drain line (no trap is needed in this line) and terminate according to local codes.

NOTE: DO NOT use a torch or flame near the plastic drain pan coupling.

NOTE: DO NOT tighten the drain pipe excessively. Support the condensate piping and traps outside the unit to prevent strain on the drain connection.

Figure 7: Typical Split/Air Handler Installation

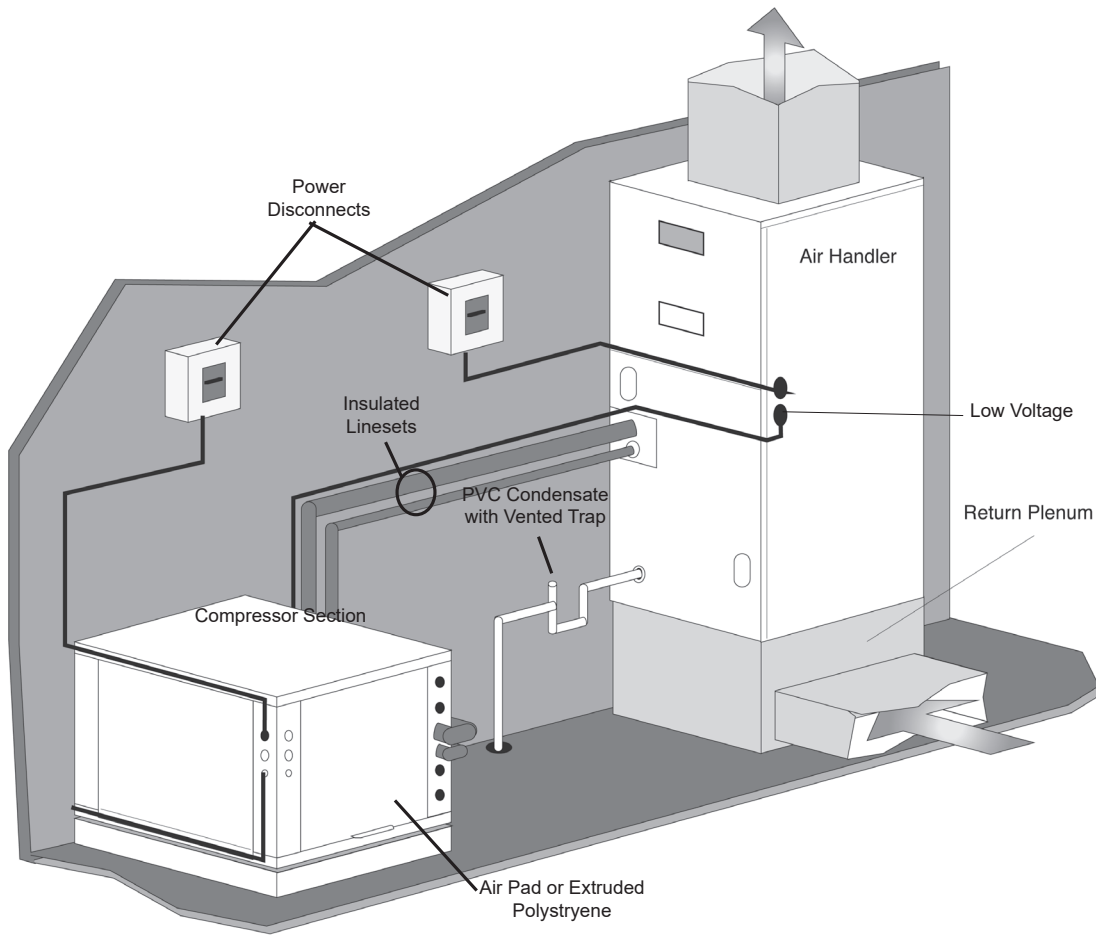

Installation (Cont.)

AXM CONTROL

The Digital Air Handler (WDG) is equipped with a communicating AXM board to allow communication with the communicating compressor section (WDG) and Communicating (ATC) Thermostat.

The AXM control allows a 4-wire connection with Communicating DXM2.5 board and ATC Communicating Thermostat. It can also be connected to a non-communicating thermostat and compressor section using up to 9-wires (plus additional if functionality requires). Please see Thermostat section for more details.

When a non-communicating thermostat will be used to control the system, an ATC Communicating Thermostat must be connected so that proper system communications and operation are maintained. The ATC Communicating Thermostat may be installed at an inconspicuous location near the air handler and wired to the TB1 terminal strip of the AXM control board. The ATC Communicating Thermostat should be set to the OFF mode.

Figure 8: AXM Connections

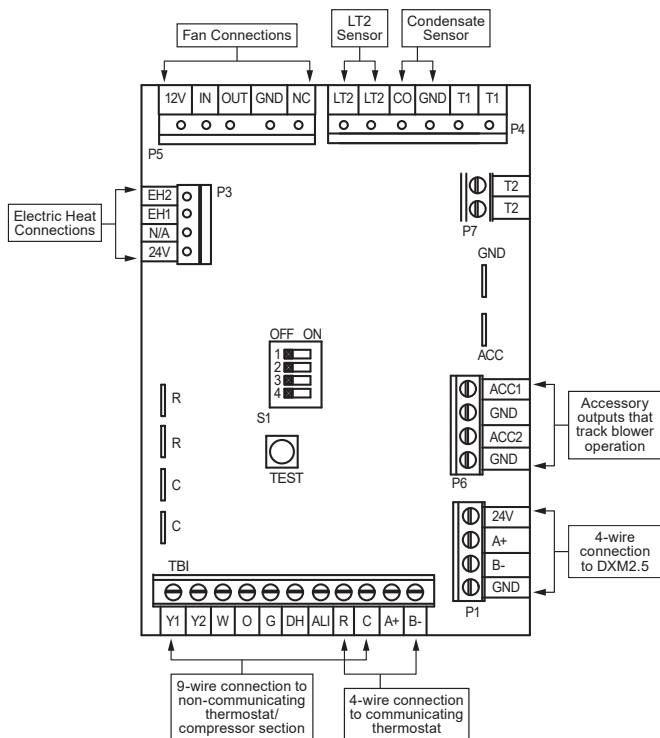

LOW AIR TEMPERATURE SENSOR INSTALLATION

WDG Digital Air Handler(s) are shipped with LT2 (Low Air Temperature) sensor installed in the air handler (Figure 5) and connected to the AXM control. No additional action required (do not clip the VIO wires).

TEST BUTTON

The test button puts the AXM into test mode, which bypasses the soft start ramping profile and the blower immediately ramps up to the nominal target speed.

FIELD SELECTABLE INPUTS

DIP SWITCHES

NOTE: In the following field configuration options, DIP switches should only be moved when power is removed from the DXM2.5 Control to ensure proper operation.

DIP #2 – Dehumidification Mode: Provides selection of normal or Dehumidification Fan Mode. In Dehumidification Mode, the fan speed will be adjusted for Cooling. In Normal Mode, the fan speed will be normal during Cooling.

On = Dehumidification Mode. Off = Normal Fan Mode.

Rest of the DIP switches are not used.

ACCESSORY CONNECTION/ CONFIGURATION

The AXM board includes two Accessory outputs available that track the blower operation. The DXM2.5 board contained in the WDG compressor section contains additional Accessory outputs which are configurable. See the DXM2.5 AOM for more details.

Electrical – Thermostat Wiring

THERMOSTAT INSTALLATION

The thermostat should be located on an interior wall in a larger room, away from supply duct drafts. DO NOT locate the thermostat in areas subject to sunlight, drafts or on external walls. The wire access hole behind the thermostat may in certain cases need to be sealed to prevent erroneous temperature measurement. Position the thermostat back plate against the wall so that it appears level and so the thermostat wires protrude through the middle of the back plate. Mark the position of the back plate mounting holes and drill holes with a 3/16" (5 mm) bit. Install supplied anchors and secure plate to the wall. Thermostat wire must be 18 AWG wire. Wire the appropriate thermostat as shown in Figures 9 and 10 to the low voltage terminal strip on the ECM control board. Practically any heat pump thermostat will work with these units, provided it has the correct number of heating and cooling stages.

Figure 9: 4-Wire Connection to Communicating Thermostat, AXM Communicating Control and Digital Splits

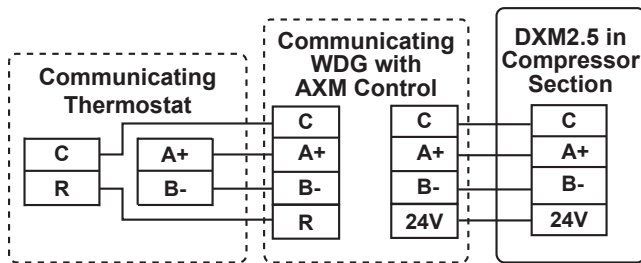

Thermostat Connections

- C 24V Common for Control Circuit
- R 24V Supply for Control Circuit
- A+ Communications (Positive)
- B- Communications (Negative)

Figure 10: Connection to Non-Communicating Thermostat and AXM communicating control in Digital Air Handler (WDG)

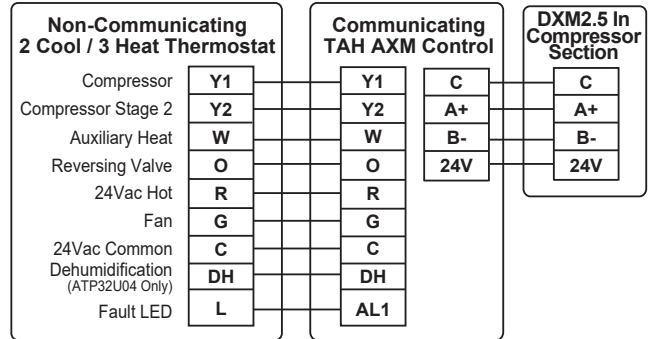

When a non-communicating thermostat will be used to control the system, a Communicating Thermostat must be connected so that proper system communications and operation are maintained. The Communicating Thermostat may be installed at an inconspicuous location near the air handler and wired to the TB1 terminal strip of the AXM control board. The ATC Communicating Thermostat should be set to the OFF mode.



IMPORTANT: Violet jumper from FP to FP on Terminal block 2 in compressor section must be removed when unit is installed with WDG Air Handler(s) or when FP2 sensor is field installed on existing air handler.

See equipment wiring diagram for more details.

Constant Volume (CV) ECM

The Intelligent Constant Volume (CV) ECM blower motor provides unmatched functionality that saves installing and service technicians time while also providing increased comfort levels to occupants.

CV ECM's are programed to maintain a constant CFM across a wide range of external static pressures (ESP). This functionality differs from traditional PSC or even Constant Torque (CT) ECM's. With traditional PSC and CT ECM fan motors, as ESP is increased CFM is reduced. To increase or decrease the speed of the fan motor requires a fan motor switch or a technician to wire into a different motor tap. CT ECM's provide increased efficiency over PSC motors but with no additional functionality. With a CV ECM, as changes in ESP occur the fan motor will adjust its speed to deliver the desired CFM (within its operating range). This ensures the system is delivering the airflow and capacity it was designed for.

A major benefit of the CV ECM over other fan motor types is its ability to adjust airflow remotely through the directly at the unit with a communicating diagnostic service tool or thermostat. Airflow levels can be adjusted in increments of 25 CFM from the units minimum and maximum CFM range (see CV ECM configuration table for details). This functionality allows technicians to dial in airflow during start-up and commissioning via an easy to use service tool. During operation occupants may have a desire for airflow adjustments. Reducing CFM can reduce airflow sound levels and increase cooling dehumidification (latent capacity). Technicians can easily make these adjustments without making wiring changes reducing service time with minimal disruption to the occupants.

The fan motor operating modes include:

- First Stage Cooling (Y1 & O)
- Second Stage Cooling (Y1, Y2, & O)
- First Stage Heating (Y1)
- Second Stage Heating (Y1 & Y2)
- Fan (G with no Y1, Y2, or W)

The CV ECM motor includes **“soft start”** and **“ramp down”** features. The soft start feature gently increases the motors rpm at blower start up resulting in quieter blower start cycles. Likewise, the ramp down feature allows the blower to slowly decrease rpm to a full stop resulting in a quieter end to each blower cycle. The ramp down feature (also known as the heating or cooling “Off Delay”) also has the functionality to be field selected by the technician in the allowable range of 0 to 255 seconds.



Airflow Configuration Screen on Mobile App

Blower Performance Data

Table: 3

Airflow in CFM with wet coil and clean air filter

Model	Max ESP (in. wg)	Fan Motor (hp)	Range	Cooling Mode		Dehumid Mode		Heating Mode		Fan Only Mode	Aux/ Emerg Mode
				Stg 2	Stg 1	Stg 2	Stg 1	Stg 2	Stg 1		
24	1.0	1/2	Default	700	525	550	425	750	600	350	850
			Maximum	1000	800	800	600	1000	850	1000	1000
			Minimum	600	450	550	400	600	450	300	700
36	0.9	1/2	Default	1050	800	850	650	1100	850	550	1350
			Maximum	1500	1100	1200	900	1500	1100	1500	1500
			Minimum	900	600	825	550	900	600	450	1350
48	1.0	1	Default	1400	1050	1100	850	1500	1150	700	1500
			Maximum	2000	1500	1600	1200	2000	1500	2000	2000
			Minimum	1200	900	1100	825	1200	900	600	1350
60	0.7	1	Default	1750	1300	1400	1050	1875	1450	875	1875
			Maximum	2300	1900	2000	1500	2300	1900	2300	2300
			Minimum	1500	1100	1375	1000	1500	1100	750	1500

Airflow is controlled within 5% up to the Max ESP shown with wet coil

Electrical - Power Wiring

⚠ WARNING! ⚠

WARNING! Electrical shock hazard - Lock unit disconnect switch in open position before servicing unit. Failure to follow this warning could result in property damage, personal injury, or death.

1. Air Handler(s) are shipped from the factory wired for 230 volts. The units may be wired for 208 or 115 volts. Follow instructions on unit wiring diagram located on blower housing and in the Service Facts document included with the unit.
2. The selection of wire and fuse sizes should be made according to the Minimum Branch Circuit Ampacity and the Maximum Overcurrent Device listed on the unit nameplate.
3. Field wiring diagrams for electric heaters and unit accessories are shipped with the accessory.
4. Wiring must conform to National and Local codes.
5. Ground unit per local codes with good safety procedures.

NOTE: If air handler is used with or without a heater, the electrical entry hole as well as any other cabinet penetrations must be sealed air-tight.

Wiring Instructions for 115v Conversion from 230 volt

1. Disconnect all power to the unit.
2. Disconnect Transformer primary orange wire from power block T2 and insulate open end of wire. Connect the white lead from transformer primary wire to power block terminal T2. **NOTE: L2 will be used as Neutral.**
3. Remove plug in ECM power wiring harness (Figure 11) and Install 2 pin jumper plug provided in control box (Figure 12).

NOTE: When supplementary heaters are installed, inspect to insure that all packaging material has been removed.

Table 4: Electric Table (115) 208/230

Model	Fan Motor FLA	Fan Motor HP	Max Fan ESP	Min Circ Amp (115) 208/230	Total Unit FLA	Max Fuse/HACR (115) 208/230
24	(7.7) 4.3	1/2	0.5	(7.8) 4.9	(7.7) 4.3	(15) 15
36	(7.7) 4.3	1/2	0.5	(7.8) 4.9	(7.7) 4.3	(15) 15
48	(12.8) 7	1	1	(14.4) 8.6	(12.8) 7	(25) 15
60	(12.8) 7	1	1	(14.4) 8.6	(12.8) 7	(25) 15

Dual Rated Voltage: (115) 208/230
 Min/Max Voltage: 115: 114/132
 Min/Max Voltage: 208/230: 197/252

Figure 11: Remove Harness Plug



Figure 12: Install Two Pin Jumper Plug

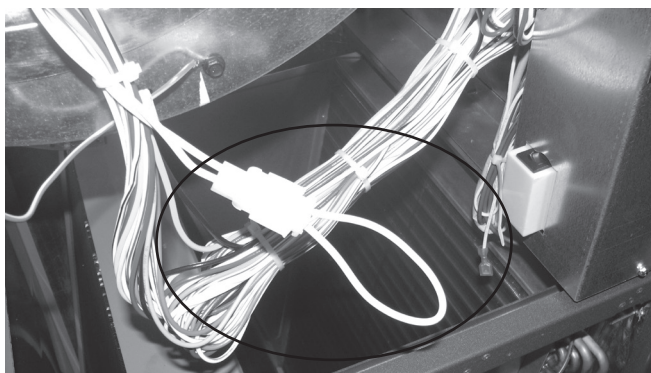

NOTE: For 115v power only. Damage will occur to motor with 230v power supply if 115v jumper is used.

Unit & System Checkout

⚠ WARNING! ⚠

WARNING! Electrical shock hazard - Lock unit disconnect switch in open position before servicing unit. Failure to follow this warning could result in property damage, personal injury, or death.

After installation has been completed, it is recommended that the air handler be checked against the following checklist:

CHECKOUT PROCEDURE

- Power:** Make sure power is "OFF" at power disconnect switch.
- Field Wiring:** Check all field wiring for tight connections. See that grounding of unit is in accord with code
- Unit Suspension:** Make sure unit suspension (if used) is secure and that there are no tools or loose debris in, around or on top of the unit.

- Ducts:** Check all duct outlets; they must be open and unrestricted.
- Drain Lines:** Check drain lines and be sure all joints are tight.
- Drain Pan:** Make sure that the unit drain pan and secondary drain pan (if applicable) and drain outlets are clear of any debris that may cause obstruction.
- Power Supply:** Check power supply for correct requirements per unit nameplate.
- Filters:** Check filters for proper size. Inform owner of proper procedure for removal and reinstallation.
- Operation:** Energize the system and carefully observe its operation; make any necessary adjustment.
- Procedure:** Instruct owner/user on the proper operating procedure and leave the Installation, Operation, Maintenance Instruction manual with the equipment.

MAINTENANCE

⚠ WARNING! ⚠

WARNING! These instructions are intended as an aid to qualified licensed service personnel for proper installation, adjustment and operation of this unit. Read these instructions thoroughly before attempting installation or operation. Failure to follow these instructions may result in improper installation, adjustment, service or maintenance possibly resulting in property damage, personal injury or death.

FILTERS

Filters must be clean to obtain maximum performance. Filters should be inspected every month under normal operating conditions and be replaced when necessary. Units should never be operated without a filter.

Washable, high efficiency, electrostatic filters, when dirty, can exhibit a very high pressure drop for the fan motor resulting in poor performance. It is especially important to provide consistent washing of these filters (in the opposite direction of the normal air flow) once per month using a high pressure wash.

IMPORTANT: Do not operate the system without a filter in place.

CONDENSATE DRAIN

In areas where airborne bacteria may produce a "slimy" substance in the drain pan, it may be necessary to treat the drain pan chemically with an algaecide approximately every three months to minimize the problem. The condensate pan

may also need to be cleaned periodically to insure indoor air quality. The condensate drain can pick up lint and dirt, especially with dirty filters. Inspect the drain twice a year to avoid the possibility of plugging and eventual overflow.

IMPORTANT: Do not use caustic household drain cleaners or bleach in the condensate pan or near the indoor coil. Drain cleaners will quickly damage the indoor coil.

AIR COIL

The air coil must be cleaned to obtain maximum performance. Check once a year under normal operating conditions and, if dirty, brush or vacuum clean. Care must be taken not to damage the aluminum fins while cleaning. CAUTION: Fin edges are sharp.

FAN MOTORS

All residential units have permanently lubricated fan motors. Further lubrication is not recommended. Conduct annual amperage check to insure amp draw is no more than 10% greater than indicated on serial data plate.

COMPRESSOR

Conduct annual amperage checks to insure that amp draw is no more than 10% greater than indicated on the serial plate data.

Warranty

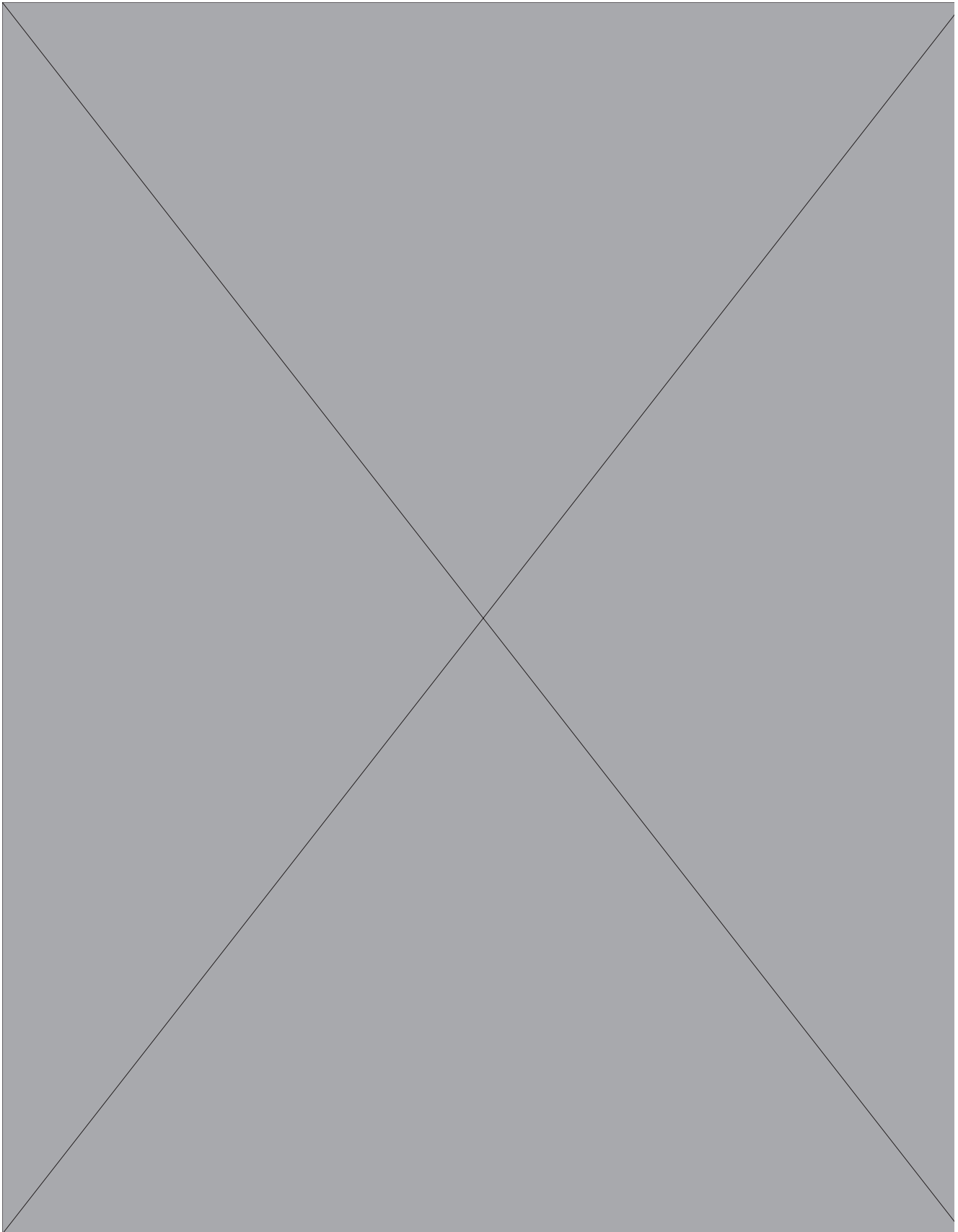

Notes

Notes

Revision History

Date	Page #	Description
Oct. 18, 2022	All	Transitioned from DXM2 to DXM2.5 unit controls
Dec. 9, 2021	14-15	Updated ATC32U02 (obsolete) to ATC32U03
Aug. 21, 2018	4	Added Warning
July 28, 2017	24	Updated certification logos
Dec., 2015	All	Update to Rev. C
Feb. 03, 2015	All	Misc Edits
Aug. 29, 2014	15	Edit Figure 7 (w)
July 21, 2014	15	Added Figure 8
Feb. 11, 2013	22	Wire Diagram Updated
Nov. 19, 2012	Various	First Published

Due to ongoing product improvements, specifications and dimensions are subject to change and correction without notice or incurring obligations. Determining the application and suitability for use of any product is the responsibility of the installer. Additionally, the installer is responsible for verifying dimensional data on the actual product prior to beginning any installation preparations.

Incentive and rebate programs have precise requirements as to product performance and certification. All products meet applicable regulations in effect on date of manufacture; however, certifications are not necessarily granted for the life of a product. Therefore, it is the responsibility of the applicant to determine whether a specific model qualifies for these incentive/rebate programs.



1900 Wellworth Ave., Jackson, MI 49203 • Ph. 517-787-2100 • www.heatcontroller.com



97B0016N18